



samlexpower®

**Evolution™ Series
Inverter/Charger**
Pure Sine Wave

Models:
EVO-1212F
EVO-1212F-HW
EVO-1224F
EVO-1224F-HW

Owner's
Manual

Please read this
manual BEFORE
operating.

Firmware:
Rev 0.79

SECTION 1.1	
Safety Instructions	3
SECTION 1.2	
Definitions	9
SECTION 1.3	
General Information – Inverter Related	12
SECTION 1.4	
General Information – Battery Related	16
SECTION 2	
Components & Layout	30
SECTION 3	
Installation	35
SECTION 4	
General Description & Principles of Operation	76
SECTION 5	
Battery Charging in Evolution™ Series	89
SECTION 6	
Operation, Protections & Troubleshooting	117
SECTION 7	
Specifications	127
SECTION 8	
Warranty	130

Disclaimer of Liability

UNLESS SPECIFICALLY AGREED TO IN WRITING, SAMLEX AMERICA INC.:

1. MAKES NO WARRANTY AS TO THE ACCURACY, SUFFICIENCY OR SUITABILITY OF ANY TECHNICAL OR OTHER INFORMATION PROVIDED IN ITS MANUALS OR OTHER DOCUMENTATION.
2. ASSUMES NO RESPONSIBILITY OR LIABILITY FOR LOSSES, DAMAGES, COSTS OR EXPENSES, WHETHER SPECIAL, DIRECT, INDIRECT, CONSEQUENTIAL OR INCIDENTAL, WHICH MIGHT ARISE OUT OF THE USE OF SUCH INFORMATION. THE USE OF ANY SUCH INFORMATION WILL BE ENTIRELY AT THE USERS RISK.

Samlex America reserves the right to revise this document and to periodically make changes to the content hereof without obligation or organization of such revisions or changes.

Copyright Notice/Notice of Copyright

Copyright © 2022 by Samlex America Inc. All rights reserved. Permission to copy, distribute and/or modify this document is prohibited without express written permission by Samlex America Inc.

SECTION 1.1 | Safety Instructions

1.1 IMPORTANT SAFETY INSTRUCTIONS

SAVE THESE INSTRUCTIONS. THIS MANUAL CONTAINS IMPORTANT INSTRUCTIONS FOR MODELS: EVO-1212F, EVO-1212F-HW, EVO-1224F AND EVO-1224F-HW THAT SHALL BE FOLLOWED DURING INSTALLATION & MAINTENANCE OF THE INVERTER/CHARGER.

THE FOLLOWING SYMBOLS WILL BE USED IN THIS MANUAL TO HIGHLIGHT SAFETY AND IMPORTANT INFORMATION:



WARNING!

Indicates possibility of physical harm to the user in case of non-compliance.



CAUTION!

Indicates possibility of damage to the equipment in case of non-compliance.



INFO

Indicates useful supplemental information.



MISE EN GARDE!

Il y a une possibilité de faire du mal physique à l'utilisateur si les consignes de sécurités sont pas suivies.



ATTENTION!

Il y a une risque de faire des dégâts à l'équipement si l'utilisateur ne suit pas les instructions.

Please read these instructions **BEFORE** installing or operating the unit to prevent personal injury or damage to the unit.



WARNING! /



CAUTION!

1. **WARNING!** To reduce risk of explosion, do not install in machinery space or in area in which ignition-protected equipment is required to be used.
2. **CAUTION!** (a) To prevent damage due to excessive vibration / shock, use on marine vessels with lengths more than 65 ft. (19.8M). (b) This unit is NOT designed for weather-deck installation. To reduce risk of electrical shock, do not expose to rain or spray.
- 3.1 **CAUTION!** EVO™ Inverter/Charger with fully automatic charging circuit charges properly rated 12V / 24V Lead Acid, Nickel Zinc (Ni-Zn) and Lithium Ion Batteries. When EVO™ Inverter/Charger is in Charge Mode, Blue LED marked "ON" will be blinking.
- 3.2 **WARNING! Lithium Ion Battery Hazard.** Option is available to use 12V / 24V nominal Lithium Ion batteries. The user/installer should ensure that charging voltages, currents and profiles are programmed appropriately to meet all operating and safety requirements of the battery being used. Make sure that the Lithium Ion Battery includes Battery Management System (BMS) with built-in safety protocols. Follow the instructions specified by the Lithium Ion Battery manufacturer. When the EVO™ Inverter/Charger is in Charge Mode, Blue LED marked "ON" will be blinking.

SECTION 1.1 | Safety Instructions

4. **CAUTION!** For indoors use only.
5. **WARNING!** Hot Surfaces! To prevent burns, do not touch!
6. **CAUTION!** The AC input / output wiring terminals are intended for field connection using Copper conductors that are to be sized based on 75°C. See Table 1.1.1 for sizing of conductors for AC INPUT circuits and Table 1.1.2 for sizing of conductors for AC OUTPUT circuits.
7. **WARNING!** Over current protection (AC Breakers) for the AC input / output circuits has NOT been provided for EVO-1212F-HW and EVO-1224F-HW and has to be provided by the installer / user. See guidelines at Table 1.1.1 for sizing of breakers for AC INPUT circuits and Table 1.1.2 for sizing of breakers for AC OUTPUT circuits. National and Local Electrical Codes will supersede these guidelines.
8. **CAUTION!** The battery terminals are intended for field connection of battery side cables using Copper conductors that are sized based on 90°C. See Table 1.1.3 for recommended sizes of battery side cables for installation in free air and conduit respectively.
9. **WARNING!** Over current protection (fuse) for battery and External Charger circuits has NOT been provided and has to be provided by the installer / user. See guidelines at Table 1.1.3 for recommended sizes for installation in free air and conduit respectively. National and Local Electrical Codes will supersede these guidelines.
10. Tightening torques to be applied to the wiring terminals are given in Table 1.1.4.
11. This unit has been provided with integral protections against overloads.
12. **WARNING!** To reduce risk of electric shock and fire:
 - Installation should be carried out by certified installer and as per Local and National Electrical Codes.
 - Do not connect to circuit operating at more than 150 Volts to Ground.
 - Do not connect to AC Load Center (Circuit Breaker Panel) having Multi-wire Branch Circuits connected .
 - Both AC and DC voltage sources are terminated inside this equipment. Each circuit must be individually disconnected before servicing.
 - Do not remove cover. No user serviceable part inside. Refer servicing to qualified servicing personnel.
 - Do not mount in zero clearance compartment.
 - Do not cover or obstruct ventilation openings.
 - Fuse(s) should be replaced with the same type and rating as of the original installed fuse(s).
13. **WARNING!** Risk of electric shock. Use only those GFCIs that are listed at Table 1.1.5. Other types may fail to operate properly when connected to this unit.
14. **GROUNDING:** The Grounding symbol shown below is used for identifying only the field wiring equipment-grounding terminal. However, this symbol is usable with the circle omitted for identifying various points within the unit that are bonded to Ground.



Grounding Symbol / *Défaut à la terre*

15. **WARNING!** Precautions When Working With Batteries.

Lead Acid Batteries

- Batteries contain very corrosive diluted Sulphuric Acid as electrolyte. Precautions should be taken to prevent contact with skin, eyes or clothing. Wear eye protection.
- Batteries generate Hydrogen and Oxygen during charging resulting in evolution of explosive gas mixture. Care should be taken to ventilate the battery area and follow the battery manufacturer's recommendations.

SECTION 1.1 | Safety Instructions

- Never smoke or allow a spark or flame near the batteries.
- Use caution to reduce the risk of dropping a metal tool on the battery. It could spark or short circuit the battery or other electrical parts and could cause an explosion. Always use insulated tools.
- Remove metal items like rings, bracelets and watches when working with batteries. Batteries can produce a short circuit current high enough to weld a ring or the like to metal and thus cause a severe burn.
- If you need to remove a battery, always remove the Ground terminal from the battery first. Make sure that all the accessories are off so that you do not cause a spark.

Lithium Ion Batteries

- Ensure that the battery includes Battery Management System (BMS) with built-in safety protocol.
- Ensure that voltage, current and charging profile settings of the charger are correct
- Ensure that the Battery Management System (BMS) of the battery is able to provide contact closure signal to the EVO™ Inverter/Charger under conditions of (i) over voltage / over heating (to stop charging) and (ii) deep discharge (to stop inverting) [Refer to Section 5.11.2].



MISE EN GARDE! /  **ATTENTION!**

1. **MISE EN GARDE!** Pour réduire les risques d'explosion, ne pas installer dans les locaux de machines ou dans la zone où l'équipement protégé contre les incendies doit être utilisé.
2. **ATTENTION!** Cet appareil est conçu pour une installation PAS Météo-pont. Pour réduire les risques de choc électrique, ne pas exposer à la pluie ou à la neige.
 - 3.1 **ATTENTION!** L'onduleur / chargeur EVO™ avec circuit de charge entièrement automatique charge des batteries plomb-acide, nickel-zinc (Ni-Zn) et Lithium-Ion 12V / 24V correctement dimensionnées. Lorsque l'onduleur / chargeur EVO™ est en mode de charge, la DEL bleue marquée «ON» clignote.
 - 3.2 **ATTENTION! Danger pour la batterie lithium-ion.** L'option est disponible pour utiliser des batteries au lithium de 12V / 24V. L'utilisateur / installateur doit s'assurer que les tensions de charge, les courants et les profils sont programmés de façon appropriée pour répondre à toutes les exigences de fonctionnement et de sécurité de la batterie utilisée. L'onduleur / chargeur EVO™ est alors en mode de charge, le voyant bleue marqué "ON" clignote.
4. **ATTENTION!** Pour éviter les dommages dus à des vibrations excessives / choc, ne pas utiliser sur les navires plus petits avec des longueurs de moins de 65 pi. (19,8).
5. **MISE EN GARDE!** Surfaces chaudes! Pour éviter les brûlures, ne touchez pas.
6. **ATTENTION!** Les bornes de câblage entrée / sortie CA sont prévus pour un raccordement sur le terrain avec des conducteurs de cuivre qui doivent être dimensionnés en fonction de 75 ° C. Voir le tableau 1.1.2 et pour le dimensionnement des conducteurs pour les circuits d'entrée CA et le tableau 1.2 pour le dimensionnement des conducteurs pour les circuits de sortie AC.
7. **MISE EN GARDE!** Protection contre les surintensités (AC Les disjoncteurs) pour l'AC circuits d'entrée / de sortie n'a pas été fournie pour EVO-1212F-HW / 1224F-HW et doit être fournie par l'installateur/ utilisateur. Voir les lignes directrices à tableau 1.1.1 pour le dimensionnement des disjoncteurs pour les circuits d'entrée CA et le tableau 1.1.2 pour le dimensionnement des disjoncteurs pour les circuits de sortie AC. Codes électriques nationaux et locaux remplaceront ces lignes directrices.

SECTION 1.1 | Safety Instructions

8. **ATTENTION!** Les bornes de la batterie sont destinés pour le champ Connexion à l'aide de conducteurs de cuivre qui sont dimensionnés en fonction de 90°C. Voir les tableau 1.1.3 pour les tailles recommandées pour l'installation à l'air libre et conduit respectivement.
9. **MISE EN GARDE!** Protection contre les surintensités (fusible) pour la batterie et les circuits chargeur externe n'a pas été fournis et a fourni à l'installateur / utilisateur. Voir les lignes directrices à tableau 1.1.3 pour les tailles recommandées pour l'installation à l'air libre et conduit respectivement. Codes électriques nationaux et locaux remplaceront ces lignes directrices.
10. Couples de serrage pour être appliqués sur les bornes de câblage sont donnés dans le tableau 1.1.4.
11. Cet appareil a été fourni avec des protections intégrées contre les surcharges.
12. **MISE EN GARDE!** Pour réduire les risques de choc électrique et d'incendie:
 - L'installation doit être effectuée par un installateur certifié et selon les codes électriques locaux et nationaux
 - Ne pas se connecter au circuit fonctionnant à plus de 150 volts à la terre
 - Ne pas se connecter au Centre de charge AC (Circuit de panneau de disjoncteurs) ayant Direction Multi-fil circuits reliés
 - Les deux sources de tension AC et DC sont terminées à l'intérieur de cet équipement. Chaque circuit doit être déconnecté individuellement avant l'entretien
 - Ne pas retirer le couvercle. Aucune partie réparable par l'utilisateur à l'intérieur. Faites appel à un installateur qualifié
 - Ne pas monter dans zéro compartiment de jeu
 - Ne pas couvrir ou obstruer les ouvertures de ventilation.
 - Fusible (s) doit être remplacé par le même type de fusible du fusible installé d'origine (s)
13. **MISE EN GARDE!** Risque de choc électrique. N'utilisez que les GFCIs qui sont indiqués au tableau 1.1.5. D'autres types peuvent ne pas fonctionner correctement lorsqu'il est connecté à cet appareil.
14. **MISE À LA TERRE:** Le symbole de mise à la terre ci-dessous est utilisé pour identifier uniquement l'équipement terminal de terre-câblage. Toutefois, ce symbole est utilisable avec le cercle omis pour identifier divers points de l'unité qui sont liés à la masse.

 Grounding Symbol / Défaut à la terre

15. **MISE EN GARDE!** Précautions lorsque vous travaillez avec des piles.

Batteries au plomb

- Les batteries contiennent de très corrosif de l'acide sulfurique dilué comme électrolyte. Des précautions doivent être prises pour éviter tout contact avec la peau, les yeux ou les vêtements. Porter des lunettes de protection.
- Générer de l'hydrogène des batteries et de l'oxygène au cours de la charge résultant de l'évolution du mélange de gaz explosifs. Il faut prendre soin de bien aérer la zone de la batterie et de suivre les recommandations du fabricant.
- Ne jamais fumer ou permettre qu'une étincelle ou une flamme à proximité des batteries.
- Procédez avec précaution pour réduire le risque de chute d'un outil métallique sur la batterie. Il pourrait déclencher ou court-circuit de la batterie ou d'autres pièces électriques et pourraient provoquer une explosion. Toujours utiliser des outils isolés.

SECTION 1.1 | Safety Instructions

- Retirer les objets métalliques tels que bagues, bracelets et montres lors de travaux avec des batteries. Les batteries peuvent produire un courant de court-circuit suffisamment haut pour souder un anneau ou similaires à metal et donc provoquer des brûlures sévères.
- Si vous avez besoin de retirer la batterie, retirez toujours la borne de masse de la batterie en premier. S'assurer que tous les accessoires sont off afin de ne pas provoquer une étincelle.

Les batteries au lithium-ion

- S'assurer que la batterie comprend Battery Management System (BMS) avec protocole de sécurité intégré.
- S'assurer que la tension, le courant et les paramètres de profil de charge le chargeur sont corrects
- S'assurer que le système de gestion de la batterie (BMS) de la batterie est en mesure de fournir de la fermeture du contact signal à l'onduleur/chargeur EVO™ dans des conditions de (i) surtension / plus de chauffage (d'arrêter le chargement) et (ii) une décharge profonde (pour arrêter l'inversion) [Se reporter à la Section 5.11.2].

TABLE 1.1.1 SIZING OF AC INPUT WIRING AND BREAKERS (Refer to Section 3.8.1, Table 3.2 for more details)

Model No. (Rated Output Power in Inverter Mode) (Column 1)	Current Rating of AC Input Breaker (15, Fig 2.1) (Column 2)	NEC Ampacity = 125% of Column 2 (Column 3)	Conductor Size Based on NEC Ampacity at Column 5 (Column 4)	Size of Breaker Based on Column 4 (Column 5)
EVO-1212F (1200VA, 10A)	20A	25A	AWG# 12	20A
EVO-1212F-HW (1200VA, 10A)	20A	25A	AWG# 12	20A
EVO-1224F (1200VA, 10A)	20A	25A	AWG# 12	20A
EVO-1224F-HW (1200VA, 10A)	20A	25A	AWG# 12	20A

Table 1.1.2 AC OUTPUT WIRING AND BREAKERS (Refer to Section 3.9.2, Table 3.3 for more details)

Model No. (Rated Power in Inverter Mode) (Column 1)	Rated AC Output Current in Inverter Mode (Column 2)	NEC Ampacity = 125% of Column 2 (Column 3)	Wire Size based on NEC Ampacity at Column 3 and 75°C Copper Conductor in Conduit (Column 4)	Breaker Size (Based on NEC Ampacity at Column 3) (Column 5)
EVO-1212F (1200VA)	10A	12.5A	AWG# 14	15A
EVO-1212F-HW (1200VA)	10A	12.5A	AWG# 14	15A
EVO-1224F (1200VA)	10A	12.5A	AWG# 14	15A
EVO-1224F-HW (1200VA)	10A	12.5A	AWG# 14	15A

SECTION 1.1 | Safety Instructions

TABLE 1.1.3 SIZING OF BATTERY SIDE CABLES AND EXTERNAL BATTERY SIDE FUSES
(Refer to Section 3.5.5, Table 3.1 for more details)

Model No. (Column 1)	Rated Continuous DC Input Current (Column 2)	NEC Ampacity = 125% of Rated DC Input Current at Column 2 (Column 3)	90°C Copper Conductor. Size Based on NEC Ampacity at Column (3) or 2% Voltage Drop, whichever is Thicker				External Fuse Based on NEC Ampacity at Column (3) (Column 9)
			Cable Running Distance between the Unit and the Battery (Cable Routing In Free Air)		Cable Running Distance between the Unit and the Battery (Cable Routing In Raceway)		
			Up to 5 ft. (Column 5)	Up to 10 ft. (Column 6)	Up to 5 ft. (Column 7)	Up to 10 ft. (Column 8)	
EVO-1212F	152	190	AWG #2	AWG #2/0	AWG #2/0	AWG #2/0	200A
EVO-1212F-HW							
EVO-1224F	76	95	AWG #6	AWG #4	AWG #3	AWG #3	100A
EVO-1224F-HW							
External Charger	50A	63A	AWG #6 (2% voltage drop is thicker)	AWG #2 (2% voltage drop is thicker)	AWG #6	AWG #2 (2% voltage drop is thicker)	70A

TABLE 1.1.4 TIGHTENING TORQUES

Battery Input Connectors	External Charger Input Connectors	AC Input and Output Connectors
70 kgf.cm (5.0 lbf.ft)	35 kgf.cm (2.5 lbf.ft)	7 to 12 kgf.cm (0.5 to 0.9 lbf.ft)

TABLE 1.1.5 USE OF SPECIFIED GROUND FAULT CIRCUIT INTERRUPTER (GFCI) FOR DISTRIBUTION OF AC OUTPUT POWER IN RECREATION VEHICLES

Manufacturer of GFCI	Manufacturers' Model No.	Description
Jiaxing Shouxin Electric Technology Co. Ltd	TS-15, TS-20	NEMA5-20, Duplex, 20A NEMA5-15, Duplex, 15A

SECTION 1.2 | Definitions

The following definitions are used in this manual for explaining various electrical concepts, specifications and operations:

Peak Value: It is the maximum value of electrical parameter like voltage / current.

RMS (Root Mean Square) Value: It is a statistical average value of a quantity that varies in value with respect to time. For example, a pure sine wave that alternates between peak values of Positive 169.68V and Negative 169.68V has an RMS value of 120 VAC. Also, for a pure sine wave, the RMS value = Peak value \div 1.414.

Voltage (V), Volts: It is denoted by "V" and the unit is "Volts". It is the electrical force that drives electrical current (I) when connected to a load. It can be DC (Direct Current – flow in one direction only) or AC (Alternating Current – direction of flow changes periodically). The AC value shown in the specifications is the RMS (Root Mean Square) value.

Current (I), Amps, A: It is denoted by "I" and the unit is Amperes – shown as "A". It is the flow of electrons through a conductor when a voltage (V) is applied across it.

Frequency (F), Hz: It is a measure of the number of occurrences of a repeating event per unit time. For example, cycles per second (or Hertz) in a sinusoidal voltage.

Efficiency, (η): This is the ratio of Power Output \div Power Input.

Phase Angle, (ϕ): It is denoted by " ϕ " and specifies the angle in degrees by which the current vector leads or lags the voltage vector in a sinusoidal voltage. In a purely inductive load, the current vector lags the voltage vector by Phase Angle (ϕ) = 90°. In a purely capacitive load, the current vector leads the voltage vector by Phase Angle, (ϕ) = 90°. In a purely resistive load, the current vector is in phase with the voltage vector and hence, the Phase Angle, (ϕ) = 0°. In a load consisting of a combination of resistances, inductances and capacitances, the Phase Angle (ϕ) of the net current vector will be $> 0^\circ < 90^\circ$ and may lag or lead the voltage vector.

Resistance (R), Ohm, Ω : It is the property of a conductor that opposes the flow of current when a voltage is applied across it. In a resistance, the current is in phase with the voltage. It is denoted by "R" and its unit is "Ohm" - also denoted as " Ω ".

Inductive Reactance (X_L), Capacitive Reactance (X_C) and Reactance (X): Reactance is the opposition of a circuit element to a change of electric current or voltage due to that element's inductance or capacitance. Inductive Reactance (X_L) is the property of a coil of wire in resisting any change of electric current through the coil. It is proportional to frequency and inductance and causes the current vector to lag the voltage vector by Phase Angle (ϕ) = 90°. Capacitive reactance (X_C) is the property of capacitive elements to oppose changes in voltage. X_C is inversely proportional to the frequency and capacitance and causes the current vector to lead the voltage vector by Phase Angle (ϕ) = 90°. The unit of both X_L and X_C is "Ohm" - also denoted as " Ω ". The effects of inductive reactance X_L to cause the current to lag the voltage by 90° and that of the capacitive reactance X_C to cause the current to lead the voltage by 90° are exactly opposite and the net effect is a tendency to cancel each other. Hence, in a circuit containing both inductances and capacitances, the net **Reactance (X)** will be equal to the difference between the values of the inductive and capacitive reactances. The net **Reactance (X)** will be inductive if $X_L > X_C$ and capacitive if $X_C > X_L$.

SECTION 1.2 | Definitions

Impedance, Z: It is the vectorial sum of Resistance and Reactance vectors in a circuit.

Active Power (P), Watts: It is denoted as “P” and the unit is “Watt”. It is the power that is consumed in the resistive elements of the load. A load will require additional Reactive Power for powering the inductive and capacitive elements. The effective power required would be the Apparent Power that is a vectorial sum of the Active and Reactive Powers.

Reactive Power (Q), VAR: Is denoted as “Q” and the unit is VAR. Over a cycle, this power is alternatively stored and returned by the inductive and capacitive elements of the load. It is not consumed by the inductive and capacitive elements in the load but a certain value travels from the AC source to these elements in the (+) half cycle of the sinusoidal voltage (Positive value) and the same value is returned back to the AC source in the (-) half cycle of the sinusoidal voltage (Negative value). Hence, when averaged over a span of one cycle, the net value of this power is 0. However, on an instantaneous basis, this power has to be provided by the AC source. Hence, the inverter, AC wiring and over current protection devices have to be sized based on the combined effect of the Active and Reactive Powers that is called the Apparent Power.

Apparent Power (S), VA: This power, denoted by “S”, is the vectorial sum of the Active Power in Watts and the Reactive Power in “VAR”. In magnitude, it is equal to the RMS value of voltage “V” X the RMS value of current “A”. The Unit is VA. Please note that Apparent Power VA is more than the Active Power in Watts. Hence, the inverter, AC wiring and over current protection devices have to be sized based on the Apparent Power.

Maximum Continuous Running AC Power Rating: This rating may be specified as “Active Power” in Watts (W) or “Apparent Power” in Volt Amps (VA). It is normally specified in “Active Power (P)” in Watts for Resistive type of loads that have Power Factor =1. Reactive types of loads will draw higher value of “Apparent Power” that is the sum of “Active and Reactive Powers”. Thus, AC power source should be sized based on the higher “Apparent Power” Rating in (VA) for all Reactive Types of AC loads. If the AC power source is sized based on the lower “Active Power” Rating in Watts (W), the AC power source may be subjected to overload conditions when powering Reactive Type of loads.

Starting Surge Power Rating: Certain loads require considerably higher Starting Surge Power for short duration (lasting from tens of millisecs to few seconds) as compared to their Maximum Continuous Running Power Rating. Some examples of such loads are given below:

- **Electric Motors:** At the moment when an electric motor is powered ON, the rotor is stationary (equivalent to being “Locked”), there is no “Back EMF” and the windings draw a very heavy starting current (Amperes) called “Locked Rotor Amperes” (LRA) due to low DC resistance of the windings. For example, in motor driven loads like Air-conditioning and Refrigeration Compressors and in Well Pumps (using Pressure Tank), LRA may be as high as 10 times its rated Full Load Amps (FLA) / Maximum Continuous Running Power Rating. The value and duration of LRA of the motor depends upon the winding design of the motor and the inertia / resistance to movement of mechanical load being driven by the motor. As the motor speed rises to its rated RPM, “Back EMF” proportional to the RPM is generated in the windings and the current draw reduces proportionately till it draws the running FLA / Maximum Continuous Running Power Rating at the rated RPM.
- **Transformers (e.g. Isolation Transformers, Step-up / Step-down Transformers, Power Transformer in Microwave Oven etc.):** At the moment when AC power is supplied to a transformer, the transformer draws very heavy “Magnetization Inrush Current” for a few millisecs that can reach up to 10 times the Maximum Continuous Rating of the Transformer.

SECTION 1.2 | Definitions

- **Devices like Infrared Quartz Halogen Heaters (also used in Laser Printers) / Quartz Halogen Lights / Incandescent Light Bulbs using Tungsten heating elements:** Tungsten has a very high Positive Temperature Coefficient of Resistance i.e. it has lower resistance when cold and higher resistance when hot. As Tungsten heating element will be cold at the time of powering ON, its resistance will be low and hence, the device will draw very heavy Starting Surge Current with consequent very heavy Starting Surge Power with a value of up to 8 times the Maximum Continuous Running AC Power.
- **AC to DC Switched Mode Power Supplies (SMPS):** This type of power supply is used as stand-alone power supply or as front end in all electronic devices powered from Utility / Grid e.g. in audio/video/ computing devices and battery chargers (Please see Section 4 for more details on SMPS). When this power supply is switched ON, its internal input side capacitors start charging resulting in very high Inrush Current for a few millisecs (Please see Fig 4.1). This inrush current / power may reach up to 15 times the Continuous Maximum Running Power Rating. The inrush current / power will, however, be limited by the Starting Surge Power Rating of the AC source.

Power Factor, (PF): It is denoted by "PF" and is equal to the ratio of the Active Power (P) in Watts to the Apparent Power (S) in VA. The maximum value is 1 for resistive types of loads where the Active Power (P) in Watts = the Apparent Power (S) in VA. It is 0 for purely inductive or purely capacitive loads. Practically, the loads will be a combination of resistive, inductive and capacitive elements and hence, its value will be $> 0 < 1$. Normally it ranges from 0.5 to 0.8.

Load: Electrical appliance or device to which an electrical voltage is fed.

Linear Load: A load that draws sinusoidal current when a sinusoidal voltage is fed to it. Examples are, incandescent lamp, heater, electric motor, etc.

Non-Linear Load: A load that does not draw a sinusoidal current when a sinusoidal voltage is fed to it. For example, non-power factor corrected Switched Mode Power Supplies (SMPS) used in computers, audio video equipment, battery chargers, etc.

Resistive Load: A device or appliance that consists of pure resistance (like filament lamps, cook tops, toaster, coffee maker etc.) and draws only Active Power (Watts) from the inverter. The inverter can be sized based on the Active Power rating (Watts) of the Resistive Load without creating overload (except for resistive loads with Tungsten based heating element like filament lamps, Quartz/Halogen lamps and Quartz / Halogen Infrared heaters. These require higher starting surge power due to lower resistance value when the heating elements are cold).

Reactive Load: A device or appliance that consists of a combination of resistive, inductive and capacitive elements (like motor driven tools, refrigeration compressors, microwaves, computers, audio/ video etc.). The Power Factor (PF) of this type of load is < 1 e.g. AC Motors (PF = 0.4 to 0.8), AC to DC Switch Mode Power Supplies (PF = 0.5 to 0.6), Transformers (PF = 0.8) etc. These devices require Apparent Power (VA) from the inverter to operate. The Apparent Power is a vectorial sum of Active Power (Watts) and Reactive Power (VAR). *The inverter has to be sized based on the higher Apparent Power (VA) and also based on the Starting Surge Power.*

SECTION 1.3 | General Information – Inverter Related

1.3 GENERAL INFORMATION - INVERTER RELATED

General information related to operation and sizing of inverters is given in succeeding sub-sections.

1.3.1 AC Voltage Waveforms

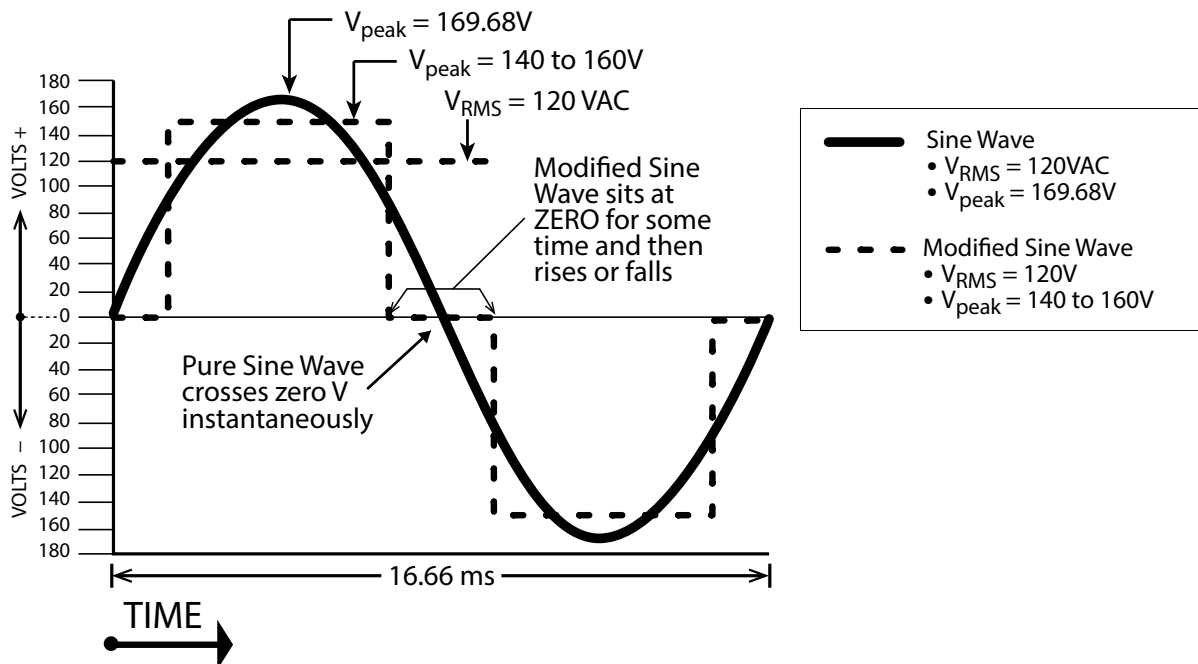

Fig 1.3.1 Pure and Modified Sine Waveforms for 120V, 60 Hz

The 120V output waveform of the Evolution™ series inverters is a Pure Sine Wave like the waveform of Utility / Grid power. Please see Sine Waveform represented in the Fig. 1.3.1 that also shows equivalent Modified Waveform for comparison.

In a Sine Wave, the voltage rises and falls smoothly with a smoothly changing phase angle and also changes its polarity instantly when it crosses 0 Volts. In a Modified Sine Wave, the voltage rises and falls abruptly, the phase angle also changes abruptly and it sits at 0V for some time before changing its polarity. Thus, any device that uses a control circuitry that senses the phase (for voltage / speed control) or instantaneous zero voltage crossing (for timing control) will not work properly from a voltage that has a Modified Sine Waveform.

Also, as the Modified Sine Wave is a form of Square Wave, it is comprised of multiple Sine Waves of odd harmonics (multiples) of the fundamental frequency of the Modified Sine Wave. For example, a 60 Hz Modified Sine Wave will consist of Sine Waves with odd harmonic frequencies of 3rd (180 Hz), 5th (300 Hz), 7th (420 Hz) and so on. The high frequency harmonic content in a Modified Sine Wave produces enhanced radio interference, higher heating effect in inductive loads like microwaves and motor driven devices like hand tools, refrigeration / air-conditioning compressors, pumps etc. The higher frequency harmonics also produce overloading effect in low frequency capacitors due to lowering of their capacitive reactance by the higher harmonic frequencies. These capacitors are used in ballasts for fluorescent lighting for Power Factor improvement and in single-phase induction motors as start and run capacitors. Thus, Modified and Square Wave Inverters may shut down due to overload when powering these devices.

SECTION 1.3 | General Information – Inverter Related

1.3.2 Advantages of Pure Sine Wave Inverters

- The output waveform is a Sine Wave with very low harmonic distortion and cleaner power like Grid / Utility supplied electricity.
- Inductive loads like microwaves, motors, transformers etc. run faster, quieter and cooler.
- More suitable for powering fluorescent lighting fixtures containing Power Factor Improvement Capacitors and single phase motors containing Start and Run Capacitors.
- Reduces audible and electrical noise in fans, fluorescent lights, audio amplifiers, TV, fax and answering machines.
- Does not contribute to the possibility of crashes in computers, weird print outs and glitches in monitors.

Some examples of devices that may not work properly with Modified Sine Wave and may also get damaged are given below:

- Laser printers, photocopiers, and magneto-optical hard drives.
- Built-in clocks in devices such as clock radios, alarm clocks, coffee makers, bread-makers, VCR, microwave ovens etc. may not keep time correctly.
- Output voltage control devices like dimmers, ceiling fan / motor speed control may not work properly (dimming / speed control may not function).
- Sewing machines with speed / microprocessor control.
- Transformer-less capacitive input powered devices like (i) Razors, flashlights, night-lights, smoke detectors etc. (ii) Some re-chargers for battery packs used in hand power tools. *These may get damaged. Please check with the manufacturer of these types of devices for suitability.*
- Devices that use radio frequency signals carried by the AC distribution wiring.
- Some new furnaces with microprocessor control / Oil burner primary controls.
- High intensity discharge (HID) lamps like Metal Halide lamps. *These may get damaged. Please check with the manufacturer of these types of devices for suitability.*
- Some fluorescent lamps / light fixtures that have Power Factor Correction Capacitors. *The inverter may shut down indicating overload.*
- Induction Cooktops.

1.3.3 Power Rating of Inverters



INFO

For proper understanding of explanations given below, please refer to definitions of Active / Reactive / Apparent / Continuous / Surge Powers, Power Factor, and Resistive / Reactive Loads at Section 1.2 under “DEFINITIONS”

The power rating of inverters is specified as follows:

- Maximum Continuous Running Power Rating
- Starting Surge Power Rating

Please read details of the above two types of power ratings in Section 1.2 under “DEFINITIONS”

SECTION 1.3 | General Information – Inverter Related



INFO

The manufacturers' specification for power rating of AC appliances and devices indicates only the Maximum Continuous Running Power Rating. The Starting Surge Power required by some specific types of devices as explained above has to be determined by actual testing or by checking with the manufacturer. This may not be possible in all cases and hence, can be guessed at best, based on some general Rules of Thumb.

Table 1.3.1 provides a list of some common AC appliances / devices that require high Starting Surge Power. An "Inverter Sizing Factor" has been recommended against each which is a Multiplication Factor to be applied to the Maximum Continuous Running Power Rating (Active Power Rating in Watts) of the AC appliance / device to arrive at the Maximum Continuous Running Power Rating of the inverter (Multiply the Maximum Continuous Running Power Rating (Active Power Rating in Watts) of the appliance / device by recommended Sizing Factor to arrive at the Maximum Continuous Running Power Rating of the inverter.

Type of Device or Appliance	Inverter Sizing Factor (See Note 1)
Air Conditioner / Refrigerator / Freezer (Compressor based)	5
Air Compressor	4
Sump Pump / Well Pump / Submersible Pump	3
Dishwasher / Clothes Washer	3
Microwave (where rated output power is the Cooking Power)	2
Furnace Fan	3
Industrial Motor	3
Portable Kerosene / Diesel Fuel Heater	3
Circular Saw / Bench Grinder	3
Incandescent / Halogen / Quartz Lamps	3
Ceramic / Positive Temperature Coefficient (PTC) type of heaters	5
Laser Printer / Other Devices using Infrared, Quartz Halogen Heaters	4
Switch Mode Power Supplies (SMPS): no Power Factor correction	2
Photographic Strobe / Flash Lights	4 (See Note 2)

NOTES FOR TABLE 1.3.1:

1 Multiply the Maximum Continuous Power Rating (Active Power Rating in Watts) of the appliance / device by the recommended sizing factor to arrive at the Maximum Continuous Running Power Rating of the Inverter.

2 For photographic strobe / flash unit, the Surge Power of the inverter should be > 4 times the Watt Sec rating of photographic strobe / flash unit.

1.3.4 Electro-Magnetic Interference (EMI) and FCC Compliance

These inverters contain internal switching devices that generate conducted and radiated electromagnetic interference (EMI). The EMI is unintentional and cannot be entirely eliminated. The magnitude of EMI is, however, limited by circuit design to acceptable levels as per limits laid down in North American FCC Standard FCC Part 15(B), Class A. These limits are designed to provide reasonable protection against harmful interference when the equipment is operated *in a residential environment*. These inverters can conduct and radiate radio frequency energy and, if not installed and

SECTION 1.3 | General Information – Inverter Related

used in accordance with the instruction manual, may cause harmful interference to radio communications. The effects of EMI will also depend upon a number of factors external to the inverter like proximity of the inverter to the EMI receptors, types and quality of connecting wires and cables etc. EMI due to factors external to the inverter may be reduced as follows:

- Ensure that the inverter is firmly grounded to the Ground System of the building or the vehicle.
- Locate the inverter as far away from the EMI receptors like radio, audio and video devices as possible.
- Keep the DC side wires between the battery and the inverter as short as possible.
- Do NOT keep the battery wires far apart. Keep them taped together to reduce their inductance and induced voltages. This reduces ripple in the battery wires and improves performance and efficiency.
- Shield the DC side wires with metal sheathing / copper foil / braiding.
- Use coaxial shielded cable for all antenna inputs (instead of 300 ohm twin leads).
- Use high quality shielded cables to attach audio and video devices to one another.
- Limit operation of other high power loads when operating audio / video equipment.

1.3.5 Characteristics of Switch Mode Power Supplies (SMPS)

Switch Mode Power Supplies (SMPS) are extensively used to convert the incoming AC power into various voltages like 3.3V, 5V, 12V, 24V etc. that are used to power various devices and circuits used in electronic equipment like battery chargers, computers, audio and video devices, radios etc. These power supplies use large capacitors in their input section for filtration. When the power supply is first turned on, there is a very large inrush current drawn by the power supply as the input capacitors are charged (The capacitors act almost like a short circuit at the instant the power is turned on). The inrush current at turn-on is several to tens of times larger than the rated RMS input current and lasts for a few milliseconds. An example of the input voltage versus input current waveforms is given in Fig. 1.3.2. It will be seen that the initial input current pulse just after turn-on is > 15 times larger than the steady state RMS current. The inrush dissipates in around 2 or 3 cycles i.e. in around 33 to 50 milliseconds for 60 Hz sine wave.

Further, due to the presence of high value of input filter capacitors, the current drawn by an SMPS (With no Power Factor correction) is not sinusoidal but non-linear as shown in Fig 1.3.3. The steady state input current of SMPS is a train of non-linear pulses instead of a sinusoidal wave. These pulses are two to four milliseconds duration each with a very high Crest Factor of around 3. Crest Factor is defined by the following equation: **CREST FACTOR = PEAK VALUE ÷ RMS VALUE**

Many SMPS units incorporate “Inrush Current Limiting”. The most common method is the NTC (Negative Temperature Coefficient) resistor. The NTC resistor has a high resistance when cold and a low resistance when hot. The NTC resistor is placed in series with the input to the power supply. The higher cold resistance limits the input current as the input capacitors charge up. The input current heats up the NTC and the resistance drops during normal operation. However, if the power supply is quickly turned OFF and back ON, the NTC resistor will be hot so its low resistance state will not prevent an inrush current event.

The inverter should, therefore, be sized adequately to withstand the high inrush current and the high Crest Factor of the current drawn by the SMPS. Normally, inverters have short duration Surge Power Rating of 2 times their Maximum Continuous Power Rating. **Hence, it is recommended that for purposes of sizing the inverter, to accommodate Crest Factor of 3, the Maximum Continuous Power Rating of the inverter should be > 2 times the Maximum Continuous Rated Power of the SMPS. For example, an SMPS rated at 100 Watts should be powered from an inverter that has Maximum Continuous Power Rating of > 200 Watts.**

SECTION 1.3 | General Information – Inverter Related

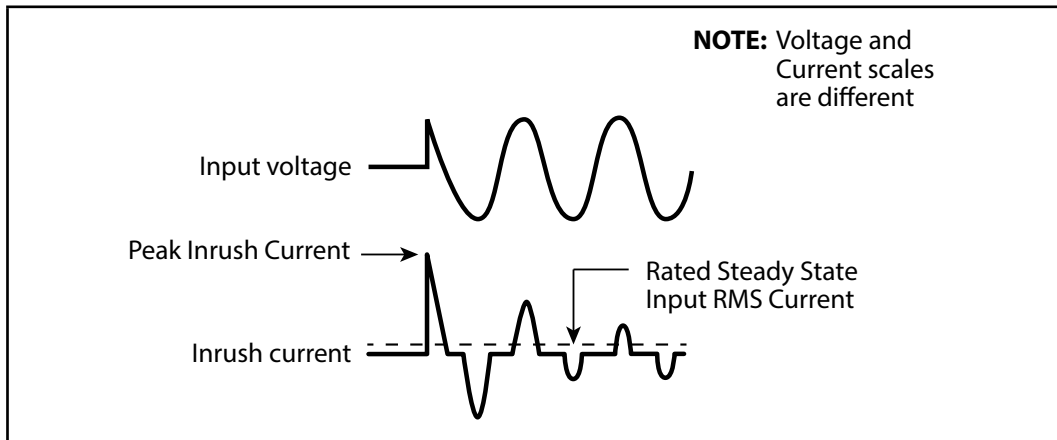

Fig 1.3.2 Inrush current in an SMPS

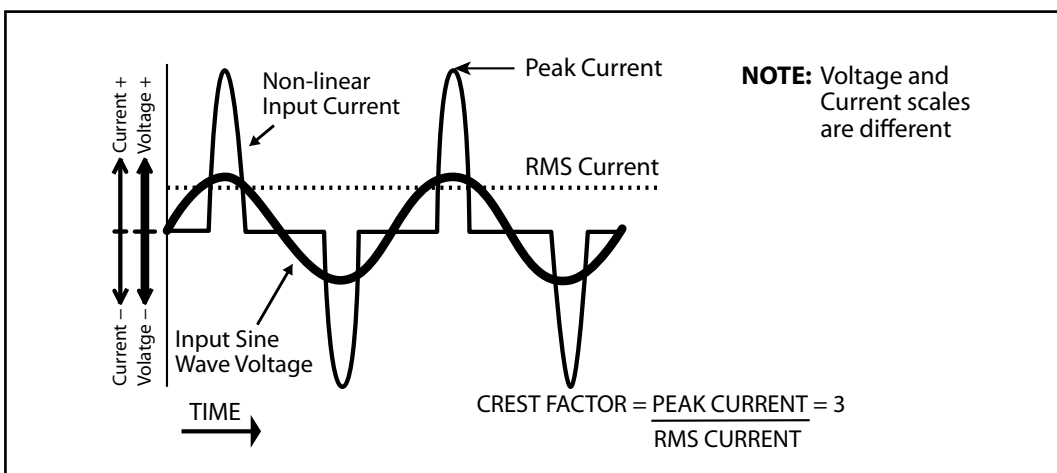

Fig 1.3.3 High Crest Factor of current drawn by SMPS

SECTION 1.4 | General Information – Battery Related



INFO

For complete information on Lead Acid Batteries and Charging Process, please visit www.samlexamerica.com > Support > White Papers > White Paper – Batteries, Chargers and Alternators

1.4.1 Lead Acid Battery – Basic Description And Electro-Chemical Reactions

1.4.1.1 A Lead Acid battery consists of a number of 2 V nominal cells (actual voltage of the cell is around 2.105 V) that are connected in series e.g. a 12 V nominal battery will have six, 2 V nominal cells in series (actual approximate voltage of the 6 cells will be $2.105 \times 6 = 12.63$ V). Each 2 V nominal cell in this battery consists of an independent

SECTION 1.4 | General Information – Battery Related

enclosed compartment that has Positive and Negative Plates (also called Electrodes) dipped in electrolyte that is composed of diluted Sulphuric Acid.

1.4.1.2 A fully charged Lead Acid Battery comprises of (i) **Positive Plates:** Lead Dioxide (PbO_2), (ii) **Negative Plates:** Sponge Lead (Pb) and (iii) **Electrolyte:** Mixture of 65% water and 35% Sulfuric Acid (H_2SO_4) with Specific Gravity = 1.265 at Standard Room Temperature of 77°F / 25°C (Fully charged condition). During discharging, electro-chemical reactions lead to: (i) **At Positive Plates:** Conversion of Lead Dioxide (PbO_2) to soft Lead Sulfate (PbSO_4) crystals, (ii) **At Negative Plates:** Conversion of Sponge Lead (Pb) to soft Lead Sulfate (PbSO_4) crystals and (iii) **In Electrolyte:** Conversion of portion of Sulfuric Acid (H_2SO_4) to water leading to reduction in Specific Gravity (1.120 for fully discharged condition).

1.4.2 Types Of Lead Acid Batteries

1.4.2.1 Sealed Lead Acid (SLA) Or Valve Regulated Lead Acid (VRLA) Batteries: These can either be Gel Cell or AGM (Absorbed Glass Mat). In a Gel Cell battery, the electrolyte is in the form of a gel. In AGM (Absorbed Glass Mat) battery, the electrolyte is soaked in Glass Mat. In both these types, the electrolyte is immobile. There are no refill caps and the battery is totally sealed. Hydrogen and Oxygen released during the charging process is not allowed to escape and is recombined inside the battery through use of Recombinant Catalyst (s). Hence, there is no water loss and the batteries are maintenance free. These batteries have safety valves on each cell to release excessive pressure that may be built up inside the cell. The Gel Cell is the least affected by temperature extremes, storage at low state of charge and has a low rate of self-discharge. An AGM battery will handle overcharging slightly better than the Gel Cell.

1.4.2.2 Non Sealed (Vented / Flooded / Wet Cell) Lead acid Batteries: In these batteries, each individual cell compartment has a refill cap that is used to top up the cell with distilled water and to measure the specific gravity of the electrolyte using a hydrometer. When fully charged, each individual cell has a voltage of approximately 2.105 V and electrolyte specific gravity of 1.265. As the cell discharges, its voltage and specific gravity drop. Thus, a healthy, fully charged, 12 V nominal battery with each of the 6 cells fully charged to 2.105 V will measure a standing voltage of 12.63 V at Standard Room Temperature of 77° F / 25° C. Also, in a healthy battery, all the individual cells will have the same voltage and same specific gravity. If there is a substantial difference in the voltages (0.2 V or higher) and specific gravities of the individual cells (0.015 or more), the cells will have to be “equalized” (Refer to Sections 1.4.3.4 and 1.4.4 regarding further details on equalization).

1.4.2.3 SLI (Starting, Lighting, and Ignition) Batteries: Everybody is familiar with the SLI batteries that are used for automotive starting, lighting, ignition and powering vehicular accessories. SLI batteries are designed to produce high current in short bursts for cranking. This current is also called also called “Cranking Amps”. SLI batteries use lots of thin plates to maximize the surface area of the plates for providing very large Cranking Amps. This allows very high starting current but causes the plates to warp when the battery is cycled. Vehicle starting typically discharges 1%-3% of a healthy SLI battery's capacity. The automotive SLI battery is not designed for repeated deep discharge where up to 80 % of the battery capacity is discharged and then recharged. If an SLI battery is used for this type of deep discharge application, its useful service life will be drastically reduced. This type of battery is not recommended for the storage of energy for inverter backup applications.

1.4.2.4 Deep Cycle Lead Acid Batteries: These batteries are designed with thick-plate electrodes to serve as primary power sources, to have a constant discharge rate, to have the capability to be deeply discharged up to 80 % capacity and to repeatedly accept recharging. They are marketed for use in recreation vehicles (RV), boats and electric golf carts – so they may be referred to as RV batteries, marine batteries or golf cart batteries.

SECTION 1.4 | General Information – Battery Related

1.4.3 Battery Charging Stages:

General descriptions of 4 stages of battery charging are given at Sections 1.4.3.1 to 1.4.3.4 below. Depending upon the type of battery and its application, different Charging Profiles can be created using appropriate charging stages.

NOTE:

7 types of Charging Profiles are available in EVO through programming parameter "CHARGING PROFILE". Refer to Section 5.6 for details.

1.4.3.1 Stage 1 - Constant Current Bulk Charge Stage: In the first stage, known as the Bulk Charge Stage, the charger delivers a constant, maximum charging current that can be safely handled as specified by the battery manufacturer. The value of the Bulk Charge Current depends upon the total Ampere Hour (Ah) capacity of the battery or bank of batteries. A battery should never be charged at very high charging current as very high rate of charging will not return the full 100% capacity as the Gassing Voltage rises with higher charging current due to "Peukert Effect". Also, very high charging current produces higher temperature in the active material of the plates resulting in loss of cohesion and shedding of the active material that settles on the bottom of the plates. Shedding of the active material results in loss of capacity. If the quantity of the shedded active material at the bottom of the plates rises, it may short the cells. As a general thumb rule, the Bulk Charging Current should be limited to 10% to 13% of the Ah capacity of the battery (20 Hour discharge rate). Higher charging current may be used if permitted by the battery manufacturer. This current is delivered to the batteries until the battery voltage approaches its Gassing Voltage of around 2.4 V per cell at 77° F / 25° C or 14.4 V for a 12 V battery and 28.8 volts for a 24 volt battery. The Bulk Charge Stage restores about 75% of the battery's capacity. The Gassing Voltage is the voltage at which the electrolyte in the battery begins to break down into Hydrogen and Oxygen gases. Under normal circumstances, a battery should not be charged at a voltage above its Gassing Voltage (except during Equalization Stage) since this will cause the battery to lose electrolyte and dry out over time. Once the Gassing Voltage is approached, the charger transfers to the next stage, known as the Absorption Stage.



INFO

As the Bulk Charge Stage is a constant current stage, the charger does not control the voltage and the voltage seen at the output terminals of the charger will be the actual battery voltage (this will rise slowly towards the Gassing Voltage under the influence of the constant charging current).

1.4.3.2 Stage 2 - Constant Voltage Absorption Stage During the Absorption Stage, the charger changes from constant current to constant voltage charging. The charging voltage is held constant near the Gassing Voltage to ensure that the battery is further charged to the full capacity without overcharging. The Absorption Stage feeds additional 40% of the capacity that adds up to a total charged capacity of around 115% to take care of around 15% loss of charging efficiency. As the output voltage of the charger is held constant, the battery absorbs the charge slowly and the current reduces gradually till all of the soft Lead Sulfate ($PbSO_4$) crystals have been converted to Lead Dioxide (PbO_2) on the Positive Plates and Sponge Lead (Pb) on the Negative Plates. The time the charger is held in the Absorption Stage before it transitions to the next Float Stage is determined in one or more of the following conditions:

- a) **By a fixed timer (e.g. 4 to 8 Hours).** This may result in overcharging of almost fully charged batteries.
- b) **When charge current drops to specified threshold:** Switching over to the Float Stage when the charge current drops below a certain threshold (e.g. 10% of the charger Bulk Charge Current). This may result in overcharging and locking in the Absorption Stage if the battery is feeding an external load that has a value > the specified threshold.

SECTION 1.4 | General Information – Battery Related

- c) **Using Adaptive Charging Algorithm:** This ensures that the battery is completely charged in a safe manner for longer battery life (Suitable for battery that does not have load connected to it). In this algorithm, the time the battery remains in Absorption and Equalization Stages is automatically made proportional to the time the battery remains in the Bulk Charge Stage. A battery that is deeply discharged will remain in Bulk Stage for a longer duration and will require longer time in the Absorption and Equalization Stages for complete charging. On the other hand, a battery that is almost completely charged will remain in the Bulk Stage for a shorter duration and consequently, will remain in Absorption and Equalization stages for a shorter duration. This will prevent overcharging / boiling of the battery. *EVO Series has 2 programmable options to use this Adaptive Charging Algorithm – (i) 3-Stage Adaptive (Table 5.2, Srl. 1) & (ii) 4-Stage Adaptive for Equalization (Section 5.8).*

1.4.3.3 Stage 3 - Constant Voltage Float Stage: The Float Stage is a maintenance stage in which the output voltage is reduced to a constant lower level, typically about 13.5 V for a 12 V battery and 27 V for a 24V battery to maintain the battery's charge without losing electrolyte through gassing and also, to compensate for self discharge. Self discharge of Lead Acid Battery is the electrical Ampere Hour (Ah) capacity that is lost when the battery is not being charged and there is no load connected to it. i.e. sits idle in storage. Self-discharge is caused by electro-chemical processes within the battery and is equivalent to application of a small electrical load. For example, Lead Acid battery stored at 30°C / 86°F would self-discharge at around 1% of remaining capacity every day. Self-discharge increases with increase in temperature. Self-discharge of the battery under long term storage will create condition equivalent to under charging and consequently, lead to "sulfation" as explained at Section 1.4.4.1.

1.4.3.4 Stage 4 - Constant Voltage Equalization Stage: This stage is normally initiated manually because it is not required every time the battery is recharged [*In EVO, it is carried out manually through programming parameter "EQUALIZE-4STAGES"* (See Section 4.4.2.12 in *EVO-RC-PLUS Remote Control Manual*)]. Normally, only vented / wet cell / flooded batteries are equalized. Some sealed AGM batteries may be equalized if recommended by the manufacturer (e.g. Life Line brand of sealed, AGM batteries). Equalization Stage is normally activated after completion of the Bulk and Absorption Stages. During the Equalization Stage, the battery is intentionally charged at a constant voltage at a value above the Gassing Voltage which is normally in the region of 2.5 to 2.7 V per cell at 25° C / 77° F (e.g. 15 to 16 V for 12 V batteries and 30 to 32 V for 24 V batteries). The time the battery remains in this stage is determined as follows:

- **By a fixed timer (e.g. 4 to 8 Hours):** This may result in overcharging of almost fully charged batteries
- **Using an automatic Adaptive Charging Algorithm:** This ensures that the battery is equalized in a safe manner for longer battery life. EVO Inverter Charger Series uses this Adaptive Charging Algorithm for Equalization. [Refer to Section 1.4.3.2 (c) for details.]

Recommendations of the battery manufacturer are to be followed for equalizing the batteries as the equalization voltage, current, time and frequency will depend upon the specific design of the battery. As a guide, a heavily used flooded battery may need to be equalized once per month and a battery in light duty service, every two to four months. The Equalization Charge Current should be a relatively low current of around 2% to 10% of the Ah capacity of the battery. Such a low current prevents an overcharge condition that results in excessive gassing and excessive loss of water.

1.4.4 Why Flooded / Wet Cell Lead Acid Batteries Are Equalized?

For proper health and long life of a Lead Acid battery, it is required to undergo an Equalization Stage (described at Section 1.4.3.4 above) during the charging process to prevent / reduce the following undesirable effects:

SECTION 1.4 | General Information – Battery Related

1.4.4.1 Sulfation: Section 1.4.1.2 above gives details of basic electrochemical reactions during charging and discharging. If the charging process is not complete due to the inability of the charger to provide the required voltage levels or if the battery is left uncharged for a long duration of time, the soft Lead Sulfate (PbSO_4) crystals on the Positive and Negative plates that are formed during discharging / self discharge are not fully converted back to Lead Dioxide (PbO_2) on the Positive plate and Sponge Lead on the Negative plate and get hardened and are difficult to dislodge through normal charging. These crystals are less-conducting and hence, introduce increased internal resistance in the battery. This increased internal resistance introduces internal voltage drop during charging and discharging. Voltage drop during charging results in overheating and undercharging and formation of more Lead Sulfate (PbSO_4) crystals. Voltage drop on discharging results in overheating and excessive voltage drop in the terminal voltage of the battery. Overall, this results in poor performance of the battery. To dislodge these hardened Lead Sulfate crystals, some chargers are designed to detect a sulfated condition at the start of the charging process and go through an initial De-sulfation Mode that sends high frequency, high voltage pulses at the natural oscillation frequency of the crystals to dislodge the hardened crystals. Sulfation may also be reduced partially by the stirring / mixing action of the electrolyte due to gassing and bubbling because of intentional overcharging during the Equalization Stage.

1.4.4.2 Electrolyte Stratification: Electrolyte stratification can occur in all types of flooded batteries. As the battery is discharged and charged, the concentration of Sulfuric Acid becomes higher at the bottom of the cell and lower at the top of the cell. The low acid concentration reduces capacity at the top of the plates, and the high acid concentration accelerates corrosion at the bottom of the plates and shortens battery life. Stratification can be minimized by the Equalization Stage by raising the charging voltage so that the increased gassing and bubbling agitates / stirs the electrolyte and ensures that the electrolyte has uniform concentration from top to bottom. The stirring action also helps to break up any Lead Sulfate crystals, which may remain after normal charging.

1.4.4.3 Unequal charging of cells: During normal charging, temperature and chemical imbalances prevent some cells from reaching full charge. As a battery is discharged, the cells with lower voltage will be drained further than the cells at higher voltage. When recharged, the cells with the higher voltage will be fully charged before the cells with the lower voltage. The more a battery is cycled, the more cell voltage separation takes place. In a healthy battery, all the individual cells will have the same voltage and same specific gravity. If there is a substantial difference in the cell voltages (0.2 V or more) and in the specific gravities (0.015 or more) of the individual cells, the cells will require equalization. Equalizing batteries helps to bring all the cells of a battery to the same voltage. During the Equalization Stage, fully charged cells will dissipate the charging energy by gassing while incompletely charged cells continue to charge.

1.4.5 Temperature Compensation To Prevent Over And Under Charging

1.4.5.1.1 Electrochemical reactions during charging / discharging of Lead Acid / Nickel Zinc (Ni-Zn) Batteries are affected by changes in the temperature of the electrolyte. These type of batteries have a Negative Temperature Coefficient of Voltage i.e. the battery charging / discharging voltages will fall due to rise in electrolyte temperature and will rise due to fall in electrolyte temperature. Battery manufacturers, therefore, specify battery voltages and capacity at Standard Room Temperature of 77° F / 25° C. The Negative Temperature Coefficient is normally within a range of -3 to -5mV / °C/Cell or (i) -18 to -30mV / °C for a 6-cell, 12V battery or (ii) -36 to -60mV / °C for 12-cell, 24V battery.

1.4.5.1.2 Lithium Ion charging voltages are not affected by temperature and hence, do not require temperature compensation.

SECTION 1.4 | General Information – Battery Related

1.4.5.2 Rise / fall in the temperature of the electrolyte with respect to the Standard Room Temperature of 77° F / 25° C will require temperature compensation. Charging voltages will be required to be reduced at higher electrolyte temperature and increased at lower electrolyte temperature with respect to the Standard Room Temperature of 77° F / 25°C. If charging voltages are not temperature compensated, the battery will boil / be overcharged during higher temperatures and under charged during lower temperatures. This will result in reduced battery life / damage to the battery. *It is, therefore, desirable that a temperature compensated battery charger is used if the Room Temperature swings more than 7° F / 5°C. Temperature compensated battery chargers are provided with either internal or external Temperature Sensor.*

1.4.5.3 Effects of Over Charging: Over charging will lead to excessive amount of decomposition of water into Hydrogen and Oxygen and generation of excessive heat. As the battery electrolyte temperature rises, the battery charging voltage is required to be reduced. However, the charger voltage will not reduce in a charger that has no temperature compensation. This condition will drive more current and ,therefore, heating up the electrolyte even further. This is called “thermal runaway” and may damage the battery within a few hours:

- Flooded battery will lose water / shed pasted material.
- Sealed battery will see rise in internal pressure as the rate of generation of Hydrogen and Oxygen will be more than the designed rate of recombination provided by the Recombinant Catalyst. The battery casing will bulge excessively and the pressure release valves may open.

1.4.5.4 Effects of Under Charging – Sulfation: Refer to Section 1.4.4.1 for details.

1.4.6 Self Discharge Of Lead Acid Batteries:

1.4.6.1 Self discharge of Lead Acid Battery is the electrical Ampere Hour (Ah) capacity that is lost when the battery is not being charged and there is no load connected to it i.e. it sits idle in storage. Self-discharge is caused by electro-chemical processes within the battery and is equivalent to application of a small electrical load. For example, Lead Acid battery stored at 30°C / 86°F would self-discharge at around 1% of remaining capacity every day. Self-discharge increases with increase in temperature. Self-discharge of the battery under long term storage will create condition equivalent to under charging and consequently, lead to sulfation as explained at Sections 1.4.4.1 above. To prevent this, the battery should be “Float Charged” as explained in Section 1.4.3.3.

1.4.6.2 Float Charging of Batteries under Long Term Storage: In order to prevent sulfation due to under charging as a result of self-discharge, Lead Acid Battery under long term storage should be first fully charged and then left under continuous charge using a suitable “Float Charger” that will Float Charge the battery and provide low value of “Float Charge Current” of around 0.1% of the Ah capacity of the battery to compensate for self discharge. *Samlex Model SC-05 and SC-10 SunCharger Solar Panels may be used. These are designed to provide this “Float Charge Current” and thus, prevent sulfation.*

1.4.7 Rated Capacity Specified in Ampere-hour (Ah)

Battery capacity “C” is specified in Ampere-hours (Ah). An Ampere is the unit of measurement for electrical current and is defined as a Coulomb of charge passing through an electrical conductor in one second. The Capacity “C” in Ah relates to the ability of the battery to provide a constant specified value of discharge current (also called “C-rate” - see Section 1.4.10) over a specified time in hours before the battery reaches a specified discharged terminal voltage (Also called “End Point Voltage”) at a specified temperature of the electrolyte. As a benchmark, the automotive battery industry rates batteries at a discharge current or C-rate of C/20 Amperes corresponding to 20 Hour discharge period. The rated capacity “C” in Ah in this case will be the number of Amperes of current the

SECTION 1.4 | General Information – Battery Related

battery can deliver for 20 Hours at 80°F (26.7°C) till the voltage drops to 1.75V / Cell. i.e. 10.5V for 12V battery or 21V for 24V battery. For example, a 100 Ah battery will deliver 5A for 20 Hours.

1.4.8 Rated Capacity Specified in Reserve Capacity (RC)

Battery capacity may also be expressed as Reserve Capacity (RC) in minutes typically for automotive SLI (Starting, Lighting and Ignition) batteries. It is the time in minutes a vehicle can be driven after the charging system fails. This is roughly equivalent to the conditions after the alternator fails while the vehicle is being driven at night with the headlights on. The battery alone must supply current to the headlights and the computer/ignition system. The assumed battery load is a constant discharge current of 25A.

Reserve capacity is the time in minutes for which the battery can deliver 25 Amperes at 80°F (26.7°C) till the voltage drops to 1.75V / Cell i.e. 10.5V for 12V battery or 21V for 24V battery.

Approximate relationship between the two units is: **Capacity “C” in Ah = Reserve Capacity in RC minutes x 0.6**

1.4.9 Typical Battery Sizes

Table 1.4.1 shows details of some popular battery sizes:

BCI* Group	Battery Voltage, V	Battery Capacity, Ah
27 / 31	12	105
4D	12	160
8D	12	225
GC2**	6	220

* Battery Council International; ** Golf Cart

1.4.10 C-rate of Charge / Discharge

1.4.10.1 The rate of charge / discharge of a battery is normally expressed in “C-rate” which is a *multiple* of the *numerical value* of the battery’s Ampere Hour (Ah) Capacity (C) (*See Section 1.4.7 for information on Ampere Hour Capacity*). Few examples of C-rates (2C, 1C, 0.2C etc.) for 100Ah capacity battery (C=100 Ah) are given below:

- 2C = (2x100) A = 200A (*As the battery capacity is 100 Ah, the battery will be completely discharged in 0.5 Hrs.*)
- 1C = (1x 100) A = 100A (*As the battery capacity is 100 Ah, the battery will be completely discharged in 1 Hr.*)
- 0.2C (or C/5) = (0.2 x 100) A = 20A (*As the battery capacity is 100 Ah, the battery will be completely discharged in 5 Hrs.*)

1.4.10.2 Example for Determining C-rate of Charge for Particular Value of Charge Current:

- Determine the Ah capacity (C) of the battery – say 100 Ah (C=100 Ah)
- Determine the value of charge current – say 10 Amperes
- C-rate of charge at 10A = *Multiple* of numerical value Ampere Hour Capacity (C) = (10 ÷ 100) C = 1/10 C or 0.1C

1.4.10.3 Example for Determining C-rate of Discharge for Particular Value of Discharge Current:

- Determine the Ah capacity (C) of the battery – say 100 Ah (C=100)
- Determine the value of discharge current – say 20 Amperes
- C-rate of discharge at 20A = *Multiple* of numerical value of Ah Capacity (C) = (20 ÷ 100) C = 1/5 C

SECTION 1.4 | General Information – Battery Related

1.4.10.4 Table 1.4.2 gives some examples of typical C-rates of Discharge and applications:

TABLE 1.4.2 TYPICAL "C-rates" OF DISCHARGE	
C-rate of Discharge (Column 1)	Examples of C-rate of Discharge for 100 Ah capacity battery (Column 2)
2C	200A
1C	100A
C/5 or 0.2C (Inverter application)	20A
C/8 or 0.125C (UPS application)	12.5A
C/10 or 0.1C (Telecom application)	10A
C/20 or 0.05C (Automotive application)	5A
C/100 or 0.01C	1A

1.4.11 Charge / Discharge Curves to Determine State of Charge of Lead Acid Battery Based on its Terminal Voltage and C-rates of Charge / Discharge

1.4.11.1 Fig 1.4.1 shows examples of State of Charge / Discharge Curves for different C-rates for typical 12V / 24V Lead Acid Battery at 80°F / 26.7°C. These curves are used to determine the State of Charge / Discharge of the battery based on its terminal voltage.

The Y-Axis shows the terminal voltage of the battery. The X-Axis shows % State of Charge. % State of Discharge can be converted to % State of Charge using formula:

- % State of Charge = (100% - % State of Discharge) e.g. 80% State of Discharge = 100% - 80% = 20% State of Charge

1.4.11.2 **Example of Determining State of Charge (using Fig 1.4.1) when Charging 12V, 100Ah Battery at C-rate of 0.1C or C/10 or 10A:** Refer to Charge Curve marked C\10 of the upper 4 curves marked "CHARGE". States of Charge at different battery terminal voltages will be: (a) At 15.3V = 100% charged; (b) At 14.3V = 90% charged; (c) At 13.5V = 70% charged; (d) At 12.5V = 15% charged

1.4.11.3 **Example of Determining State of Discharge (using Fig 1.4.1) when Discharging 12V, 100Ah Battery at C-rate of 0.33C or C/3 or 33.3A:** Refer to Charge Curve marked C\3 of the lower 4 curves marked "DISCHARGE". States of Discharge at different battery terminal voltages will be: [a] At 9.5V = 100% discharged (0% charged); [b] At 10.4V = 80% discharged (20% charged); [c] At 11.5V = 28% discharged (72% charged) and [d] 11.75V = 0% discharged (100% charged)

SECTION 1.4 | General Information – Battery Related

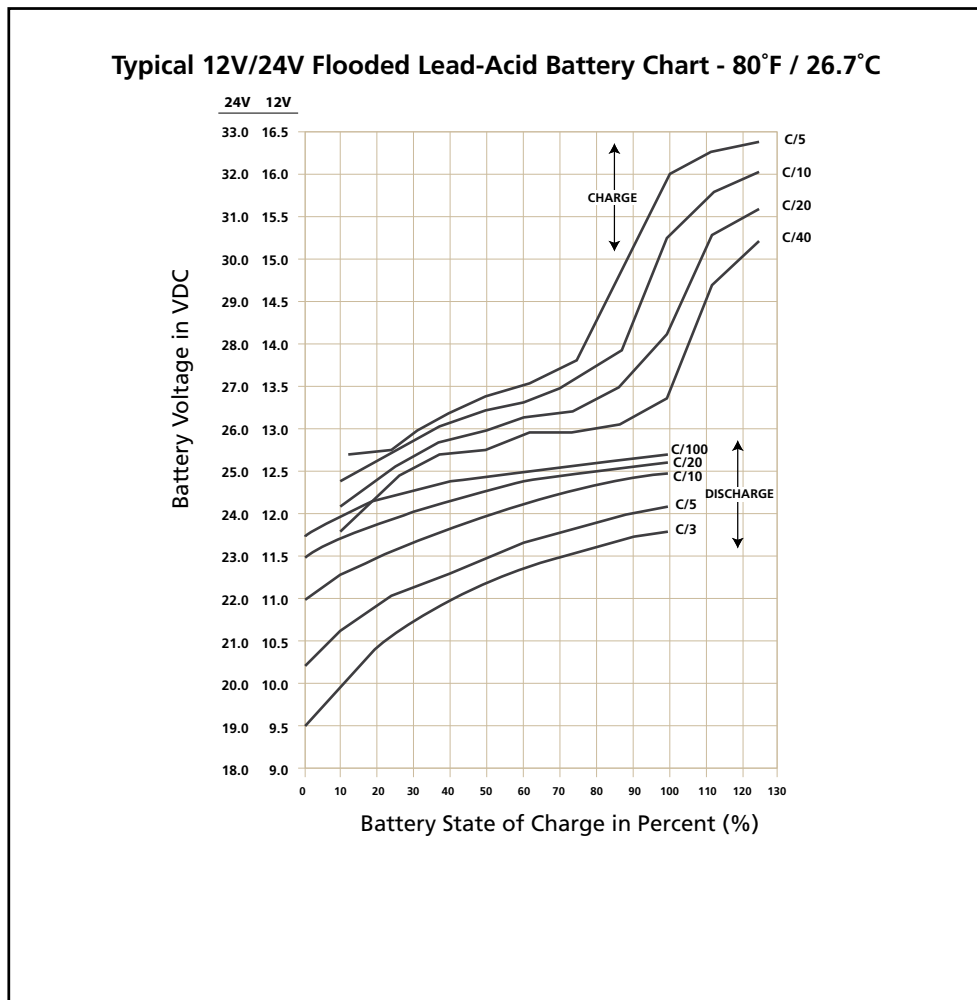

Fig 1.4.1 Charging / Discharging Curves for Typical 12V/24V Flooded Lead Acid Battery

1.4.12 Reduction in Usable Capacity at Higher Discharge Rates – Typical in Inverter Application

As stated earlier, the Ah capacity of automotive battery is normally applicable at a C-rate of C/20 (or, 0.05C). As the discharge rate is increased as in cases where the inverters are driving higher capacity loads, the usable Ah capacity reduces due to "Peukert Effect". This relationship is not linear but is more or less according to the Table 1.4.3.

TABLE 1.4.3 BATTERY CAPACITY VERSUS RATE OF DISCHARGE – C-rate	
C-rate Discharge Current	Usable Capacity (%)
C/20 or, 0.05C	100%
C/10 or, 0.10C	87%
C/8 or, 0.125C	83%
C/6 or, 0.17C	75%
C/5 or, 0.20C	70%
C/3 or, 0.34C	60%
C/2 or, 0.50C	50%
1C	40%

SECTION 1.4 | General Information – Battery Related

Table 1.4.3 shows that a 100 Ah capacity battery will deliver 100% (i.e. full 100 Ah) capacity if it is slowly discharged over 20 Hours at the rate of 5 Amperes (50W output for a 12V inverter and 100W output for a 24V inverter). However, if it is discharged at a rate of 50 Amperes (500W output for a 12V inverter and 1000W output for a 24V inverter) then theoretically, it should provide $100 \text{ Ah} \div 50 = 2 \text{ Hours}$. However, Table 1.4.3 above shows that for 2 Hours discharge rate, the capacity is reduced to 50% i.e. 50 Ah. Therefore, at 50 Ampere discharge rate (500W output for a 12V inverter and 1000W output for a 24V inverter) the battery will actually last for $50 \text{ Ah} \div 50 \text{ Amperes} = 1 \text{ Hour}$.

1.4.13 State of Charge (SOC) of a Battery – Based on “Standing Voltage”

The “Standing Voltage” of a battery under open circuit conditions (no charger or load connected to it) can approximately indicate the State of Charge (SOC) of the battery. *The “Standing Voltage” is measured after disconnecting any charging device(s) and the battery load(s) and letting the battery “stand” idle for 3 to 8 hours before the voltage measurement is taken.* Table 1.4.4 shows the State of Charge versus Standing Voltage for a typical 12V/24V battery system at 80°F (26.7°C).

Percentage of Full Charge	Standing Voltage of Individual Cells	Standing Voltage of 12V Battery	Standing Voltage of 24V Battery
100%	2.105V	12.63V	25.26V
90%	2.10V	12.6V	25.20V
80%	2.08V	12.5V	25.00V
70%	2.05V	12.3V	24.60V
60%	2.03V	12.2V	24.40V
50%	2.02V	12.1V	24.20V
40%	2.00V	12.0V	24.00V
30%	1.97V	11.8V	23.60V
20%	1.95V	11.7V	23.40V
10%	1.93V	11.6V	23.20V
0%	= / < 1.93V	= / < 11.6V	= / < 23.20V

Check the individual cell voltages / specific gravity. If the inter-cell voltage difference is more than a 0.2V, or the specific gravity difference is 0.015 or more, the cells will require equalization. Refer to Section 1.4.3.4 and 1.4.4 regarding details on equalization). *Please note that only non-sealed / vented / flooded / wet cell batteries are equalized. Do not equalize sealed / VRLA type of AGM or Gel Cell Batteries.*

1.4.14 State of Discharge of a Loaded Battery – Low Battery / DC Input Voltage Alarm and Shutdown in Inverters

Most inverter hardware estimate the State of Discharge of the loaded battery by measuring the voltage at the inverter’s DC input terminals [considering that the DC input cables are thick enough to allow a negligible voltage drop between the battery and the inverter].

SECTION 1.4 | General Information – Battery Related

Inverters are provided with a buzzer alarm to warn that the loaded battery has been deeply discharged to around 80% of the rated capacity. *Normally, the buzzer alarm is triggered when the voltage at the DC input terminals of the inverter has dropped to around 10.5V for a 12V battery or 21V for 24V battery at C-rate discharge current of C/5 Amps and electrolyte temp. of 80°F.* The inverter is shut down if the terminal voltage at C/5 discharge current falls further to 10V for 12V battery or 20V for 24V battery.

The State of Discharge of a battery is estimated based on the measured terminal voltage of the battery. The terminal voltage of the battery is dependent upon the following:

- **Temperature of the battery electrolyte:** Temperature of the electrolyte affects the electrochemical reactions inside the battery and produces a Negative Voltage Coefficient – during charging / discharging, the terminal voltage drops with rise in temperature and rises with drop in temperature.
- **The amount of discharging current or “C-rate”:** A battery has non linear internal resistance and hence, as the discharge current increases, the battery terminal voltage decreases non-linearly.

The discharge curves in Fig. 1.4.1 show the % State of Charge versus the terminal voltage of typical Flooded Lead Acid Battery under different charge /discharge currents, i.e. “C-rates” and fixed temperature of 80°F. *(Please note that the X-Axis of the curves shows the % of State of Charge. The % of State of Discharge will be 100% - % State of Charge).*

1.4.14.1 Low DC Input Voltage Alarm in Inverters

As stated earlier at Section 1.4.14, the buzzer alarm is triggered when the voltage at the DC input terminals of the inverter has dropped to around 10.5V for a 12V battery or 21V for 24V battery at C-rate discharge current of C/5 Amps. Please note that the terminal voltage relative to a particular State of Discharge decreases with the rise in the value of the discharge current. For example, terminal voltages for a State of Discharge of 80% (State of Charge of 20%) for various discharge currents will be as given at Table 1.4.5 (Refer to Fig. 1.4.1 for parameters and values shown in Table 1.4.5):

TABLE 1.4.5 TERMINAL VOLTAGE AND SOC OF LOADED BATTERY				
Discharge Current: C-rate	Terminal Voltage at 80% State of Discharge (20% SOC)		Terminal Voltage When Completely Discharged (0% SOC)	
	12V	24V	12V	24V
C/3 A	10.45V	20.9V	09.50V	19.0V
C/5 A	10.90V	21.8V	10.30V	20.6V
C/10 A	11.50V	23.0V	11.00V	22.0V
C/20 A	11.85V	23.7V	11.50V	23.0V
C/100 A	12.15V	24.3V	11.75V	23.5V

In the example given above, the 10.5V / 21.0V Low Battery / DC Input Alarm would trigger at around 80% discharged state (20% SOC) when the C-rate discharge current is C/5 Amps. However, for lower C-rate discharge current of C/10 Amps and lower, the battery will be almost completely discharged when the alarm is sounded. *Hence, if the C-rate discharge current is lower than C/5 Amps, the battery may have completely discharged by the time the Low DC Input Alarm is sounded.*

SECTION 1.4 | General Information – Battery Related

In view of the above, it may be seen that a fixed Low DC Input Voltage Alarm is not useful. Temperature of the battery further complicates the situation. All the above analysis is based on battery electrolyte temperature of 80°F. The battery capacity varies with temperature. Battery capacity is also a function of age and charging history. Older batteries have lower capacity because of shedding of active materials, sulfation, corrosion, increasing number of charge / discharge cycles etc. Hence, the State of Discharge of a battery under load cannot be estimated accurately. However, the low DC input voltage alarm function is designed to protect the inverter from excessive current drawn at the lower voltage.

1.4.14.2 Low DC Input Voltage Shutdown in Inverters

As explained above at Section 1.4.14, at around 80% State of Discharge of the battery at C-rate discharge current of around C/5 Amps, the Low DC Input Voltage Alarm is sounded at around 10.5V for a 12V battery or, at around 21V for 24V battery to warn the user to disconnect the battery to prevent further draining of the battery. If the load is not disconnected at this stage, the batteries will be drained further to a lower voltage and to a completely discharged condition that is harmful for the battery and for the inverter.

Inverters are normally provided with a protection to shut down the output of the inverter if the DC voltage at the input terminals of the inverter drops below a threshold of around 10V for a 12V battery or, 20V for 24V battery. Referring to the Discharge Curves given in Fig 1.4.1, the State of Discharge for various C-rate discharge currents for battery voltage of 10V / 20V is as follows: *(Please note that the X-Axis of the curves shows the % of State of Charge. The % of State of Discharge will be 100% - % State of Charge):*

- 85% State of Discharge (15% State of Charge) at very high C-rate discharge current of C/3 Amps.
- 100% State of Discharge (0 % State of Charge) at high C-rate discharge current of C/5 Amps.
- 100% discharged (0% State of charge) at lower C-rate Discharge current of C/10 Amps.

It is seen that at DC input voltage of 10V / 20V, the battery is completely discharged for C-rate discharge current of C/5 and lower.

In view of the above, it may be seen that a fixed Low DC Input Voltage Shutdown is not useful. Temperature of the battery further complicates the situation. All the above analysis is based on battery electrolyte temperature of 80°F. The battery capacity varies with temperature. Battery capacity is also a function of age and charging history. Older batteries have lower capacity because of shedding of active materials, sulfation, corrosion, increasing number of charge / discharge cycles etc. Hence, the State of Discharge of a battery under load cannot be estimated accurately. However, the low DC input voltage shut-down function is designed to protect the inverter from excessive current drawn at the lower voltage.

SECTION 1.4 | General Information – Battery Related

1.4.15 Depth of Discharge of Battery and Battery Life

The more deeply a battery is discharged on each cycle, the shorter the battery life. Using more batteries than the minimum required will result in longer life for the battery bank. A typical cycle life chart is given in the Table 1.4.6 below:

Depth of Discharge % of Ah Capacity	Cycle Life of Group 27 /31	Cycle Life of Group 8D	Cycle Life of Group GC2
10	1000	1500	3800
50	320	480	1100
80	200	300	675
100	150	225	550

NOTE: It is recommended that the depth of discharge should be limited to 50%.

1.4.16 Series and Parallel Connection of Batteries

Refer to details at Section 3.4.

1.4.17 Sizing the Inverter Battery Bank

One of the most frequently asked questions is, “how long will the batteries last?” This question cannot be answered without knowing the size of the battery system and the load on the inverter. Usually this question is turned around to ask “How long do you want your load to run?”, and then specific calculation can be done to determine the proper battery bank size. There are a few basic formulae and estimation rules that are used:

1. Active Power in Watts (W) = Voltage in Volts (V) x Current in Amperes (A) x Power Factor
2. For an inverter running from a 12V battery system, the approximate DC current required from the 12V batteries is the AC power delivered by the inverter to the load in Watts (W) divided by 10 & for an inverter running from a 24V battery system, the approximate DC current required from the 24V batteries is the AC power delivered by the inverter to the load in Watts (W) divided by 20.
3. Energy required from the battery = DC current to be delivered (A) x Time in Hours (H).

The first step is to estimate the total AC watts (W) of load(s) and for how long the load(s) will operate in hours (H). The AC watts are normally indicated in the electrical nameplate for each appliance or equipment. In case AC watts (W) are not indicated, Formula 1 given above may be used to calculate the AC watts. The next step is to estimate the DC current in Amperes (A) from the AC watts as per Formula 2 above. An example of this calculation for a 12V inverter is given below:

Let us say that the total AC Watts delivered by the inverter = 1000W.

Then, using Formula 2 above, the approximate DC current to be delivered by the 12V batteries = $1000W \div 10 = 100$ Amperes, or by 24V batteries = $1000W \div 20 = 50A$.

Next, the energy required by the load in Ampere Hours (Ah) is determined.

For example, if the load is to operate for 3 hours then as per Formula 3 above, the energy to be delivered by the 12V batteries = $100 \text{ Amperes} \times 3 \text{ Hours} = 300 \text{ Ampere Hours (Ah)}$, or by the 24V batteries = $50A \times 3 \text{ Hrs} = 150 \text{ Ah}$.

SECTION 1.4 | General Information – Battery Related

Now, the capacity of the batteries is determined based on the run time and the usable capacity.

From Table 1.4.3 “Battery Capacity versus Rate of Discharge”, the usable capacity at 3 Hour discharge rate (C/3) is 60%. Hence, the actual capacity of the 12V batteries to deliver 300 Ah will be equal to: $300 \text{ Ah} \div 0.6 = 500 \text{ Ah}$, and the actual capacity of the 24V battery to deliver 150 Ah will be equal to $150 \text{ Ah} \div 0.6 = 250 \text{ Ah}$.

And finally, the actual desired rated capacity of the batteries is determined based on the fact that normally only 80% of the capacity will be available with respect to the rated capacity due to non availability of ideal and optimum operating and charging conditions. So the final requirements will be equal to:

FOR 12V BATTERY: $500 \text{ Ah} \div 0.8 = 625 \text{ Ah}$ (note that the actual energy required by the load was 300 Ah).

FOR 24V BATTERY: $250 \text{ Ah} \div 0.8 = 312.5 \text{ Ah}$ (Note that the actual energy required was 150 Ah).

It will be seen from the above that the final rated capacity of the batteries is almost 2 times the energy required by the load in Ah. Thus, as a Rule of Thumb, the Ah capacity of the batteries should be twice the energy required by the load in Ah.

1.14.18 Charging Batteries

Batteries can be charged by using good quality AC powered battery charger or from alternative energy sources like solar panels, wind or hydro systems. Make sure an appropriate Battery Charge Controller is used. It is recommended that batteries may be charged at 10% to 20% of their Ah capacity (Ah capacity based on 20 Hr Discharge Rate).

Based on the application, batteries may be charged using 2-Stage / 3-Stage / 4-Stage Charging Profiles as follows:

- **Float Application Charging (2-Stage)**

Stage 1 (Bulk Stage at constant current) → Stage 2 (Absorption Stage at constant voltage. May also be called Float Stage in some applications).

- **Normal Charging (3-Stages)**

Stage 1 (Bulk Stage at constant current) → Stage 2 (Absorption Stage at constant voltage) → Stage 3 (Float Stage at constant voltage)

- **Equalization Charging (4-Stages)**

Stage 1 (Bulk Stage at constant current) → Stage 2 (Absorption Stage at constant voltage) → Stage 3 (Equalization Stage at constant voltage) → Stage 4 (Float Stage at constant voltage)

Please refer to Section 5 for details of charging algorithm used in the Battery Charger Section of EVO™ Series Inverter/Charger.

SECTION 2 | Components & Layout

2. LAYOUT

2.1 LAYOUT OF EVO-1212F AND EVO1224F – FRONT VIEW

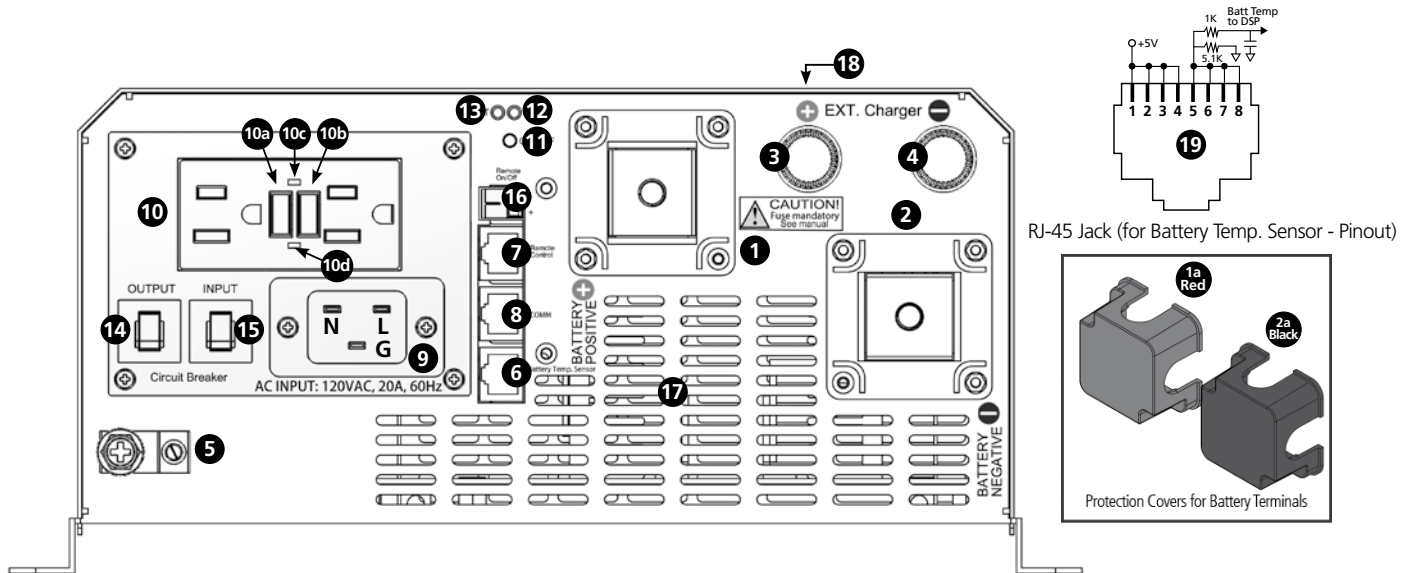

Fig 2.1 Layout of Front side EVO-1212F / EVO-1224F

Legend for Fig 2.1

1. Battery Positive (+) Input Connector (marked "BATTERY POSITIVE"): Stud and Nut, M8 (Pitch 1.25 mm)
 - 1a Red Protective Cover for Battery Positive (+) Input Connector – mounted using 2 pcs of M3 (Pitch 0.5 mm) x 10 mm long screws
2. Battery Negative (-) Input Connector (marked "BATTERY NEGATIVE"): Stud and Nut, M8 (Pitch 1.25)
 - 2a Black Protective Cover for Battery Negative (-) Input Connector - mounted using 2 pcs of M3 (Pitch 0.5 mm) x 10 mm long screws
3. External Charge Controller Positive (+) Input Connector (marked "+ EXT. charger"): Stud and Thumb Nut, M6 (Pitch 1 mm)
4. External Charge Controller Negative (-) Input Connector (marked "- EXT. charger"): Stud and Thumb Nut, M6 (Pitch 1 mm)
5. DC Side Ground Connector (marked "⏏") – Hole Diameter 6.5 mm for AWG #4 to #6; Set screw M6 (Pitch 0.75 mm)
6. RJ-45 Jack marked "Battery Temp. Sensor" (Pinout at 19) is used for 2 functions as follows:
 - a) Connecting Battery Temperature Sensor "EVO-BCTS"[Fig 2.5(a)] for temperature compensation when Parameter "BATTERY TYPE" is set for option "0=Lead Acid", or
 - b) Connecting potential free contact switching signal from Lithium Ion Battery Management System (BMS) to stop charging/ stop inverting [See Sections 3.16 & 5.11.2]
7. RJ-45 Jack (marked "Remote Control") for "EVO-RC Plus" Remote Control
8. RJ-45 Jack (marked "COMM") - for future use.
9. Male AC Power Inlet Plug – Rating 20A (IEC60320 C-20). Will require 20A rated Female Socket Connector (IEC 60320 C-19). For convenience, the connector has been supplied with the unit (See Section 2.6 – "Contents of Package")
10. NEMA5-15R Duplex GFCI Outlets for 120 VAC output [See Section 3.6.1.2 for details].
 - 10a. Test Button
 - 10b. GFCI Reset Button
 - 10c. Red LED: GFCI Life End Alarm
 - 10d. Green LED: GFCI ON
11. ON/Off Push Button
12. Blue LED "ON"
13. Red LED "Fault"
14. AC output Breaker, 15A
15. AC Input Breaker, 20A
16. Connector (marked "Remote On/Off") for On/Off Control through external +12V signal (9 – 15V, < 10mA): Screw M2.5; Wire size AWG#30 to AWG#12. Refer to Section 6.2 for details.
 - **CAUTION!** Observe correct polarity - Upper terminal is Negative and Lower terminal is Positive
17. Air inlet vents for 2 variable speed, temperature controlled cooling fans.
18. Removable top cover: Fixed with 8 screws – M4 (Pitch 0.7mm) x 4 mm
19. Pinout for RJ-45 Jack marked "Battery Temp. Sensor" (6, Fig 2.1)

SECTION 2 | Components & Layout

2.2 LAYOUT OF EVO-1212F / 1212F-HW AND EVO-1224F / 1224F-HW – BACK VIEW



Fig 2.2 Layout of Back Side - EVO-1212F / 1212F-HW and EVO-1224F / 1224F-HW

Legend for Fig 2.2

1. Air outlet vents for 2 variable speed, temperature controlled cooling fans (**fans are not shown**).

2.3 LAYOUT OF EVO-1212F-HW AND EVO-1224F-HW – FRONT VIEW

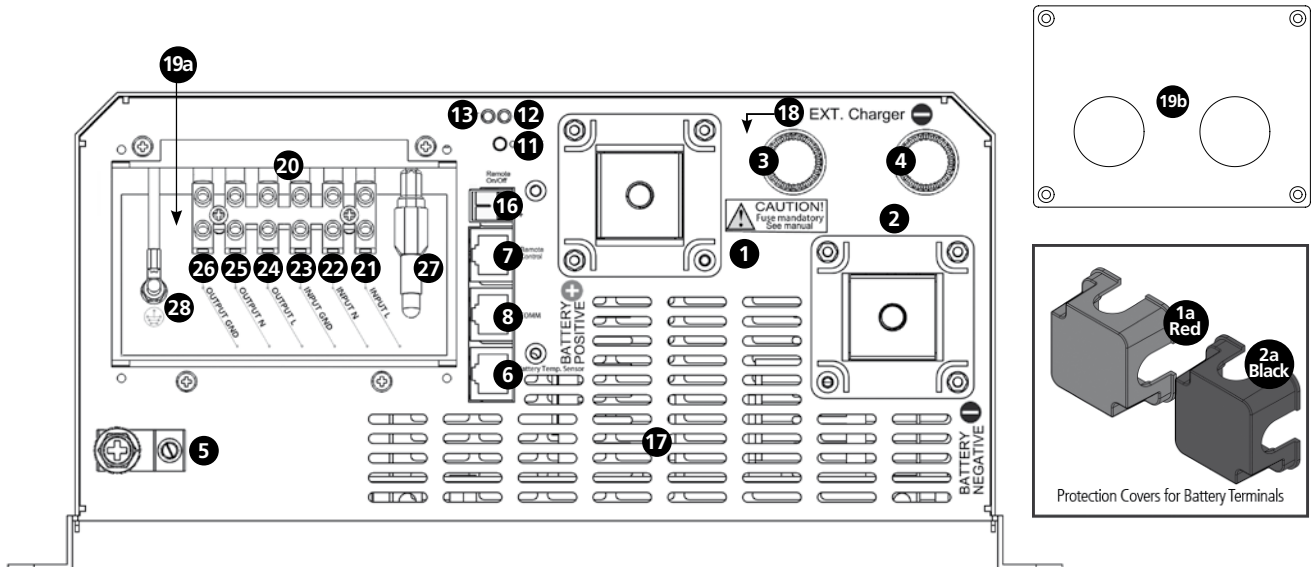

Fig 2.3 Hardwired AC Input and output connections: EVO-1212F-HW and EVO-1224F-HW

SECTION 2 | Components & Layout

LEGEND for Fig 2.3

1. Battery Positive (+) Input Connector (marked "BATTERY POSITIVE"): Stud and Nut, M8 (Pitch 1.25mm)
 - 1a Red Protective Cover for Battery Positive (+) Input Connector – mounted using 2 pcs of M3 (Pitch 0.5mm) x 10mm long screws
2. Battery Negative (-) Input Connector (marked "BATTERY NEGATIVE"): Stud and Nut, M8 (Pitch 1.25)
 - 2a Black Protective Cover for Battery Negative (-) Input Connector - mounted using 2 pcs of M3 (Pitch 0.5mm) x 10mm long screws
3. External Charge Controller Positive (+) Input Connector (marked "+ EXT. charger"): Stud and Thumb Nut, M6 (Pitch 1mm)
4. External Charge Controller Negative (-) Input Connector (marked "- EXT. charger"): Stud and Thumb Nut, M6 (Pitch 1 mm)
5. DC Side Ground Connector (marked "⏚") – Hole Diameter 6.5mm for AWG #4 to #6; Set screw M6 (Pitch 0.75mm)
6. RJ-45 Jack marked "Battery Temp. Sensor"(Pinout at 19) is used for 2 functions as follows:
 - a) Connecting Battery Temperature Sensor "EVO-BCTS"[Fig 2.5(a)] for temperature compensation when Parameter "BATTERY TYPE" is set for option "0=Lead Acid", or
 - b) Connecting potential free contact switching signal from Lithium Ion Battery Management System (BMS) to stop charging/ stop inverting [*See Sections 3.16 & 5.11.2*]
7. RJ-45 Jack (marked "Remote Control") for "EVO-RC Plus" Remote Control
8. RJ-45 Jack (marked "COMM") - for future use
9. Blank
10. Blank
11. ON/Off Push Button
12. Blue LED "ON"
13. Red LED "Fault"
14. Blank
15. Blank
16. Connector (marked "Remote On/Off") for On/Off Control through external +12V signal (9 – 15V, < 10mA): Screw M2.5; Wire size AWG#30 to AWG#12
 - CAUTION! Observe correct polarity - Upper terminal is Negative and Lower terminal is Positive
17. Air inlet vents for 2 variable speed, temperature controlled cooling fans.
18. Removable top cover: Fixed with 8 screws – M4 (Pitch 0.7mm) x 4mm
- 19(a). Pocket with Terminal Block for hard wiring
- 19(b). Plate to cover Pocket 19(a). Uses 4 mounting screws M3 (Pitch 0.5mm) x 6mm long (not shown).
The plate has 2 holes (27.8 mm /13/32" dia.) for 3/4" Trade Size Fitting for conduit / cable entry
20. Terminal Block for AC Input and AC output Connections: Terminal Hole: 3.5 mm x 3.0 mm for up to AWG#10; Set Screw M3 (0.5mm Pitch) x 6 mm long
21. INPUT L
22. INPUT N
23. INPUT GND
24. OUTPUT L
25. OUTPUT N
26. OUTPUT GND
27. Insulated Male / Female Quick Disconnect for disconnecting Output Neutral to Chassis Ground bond in Inverter Mode (Please see Sections 4.5.1 to 4.5.3 and Fig 3.12(a) and 3.12(b))
28. AC Input and Output Ground connection to metal chassis: Stud and Nut; M4 (Pitch 0.7mm)

SECTION 2 | Components & Layout

2.4 REMOTE CONTROL EVO-RC-PLUS

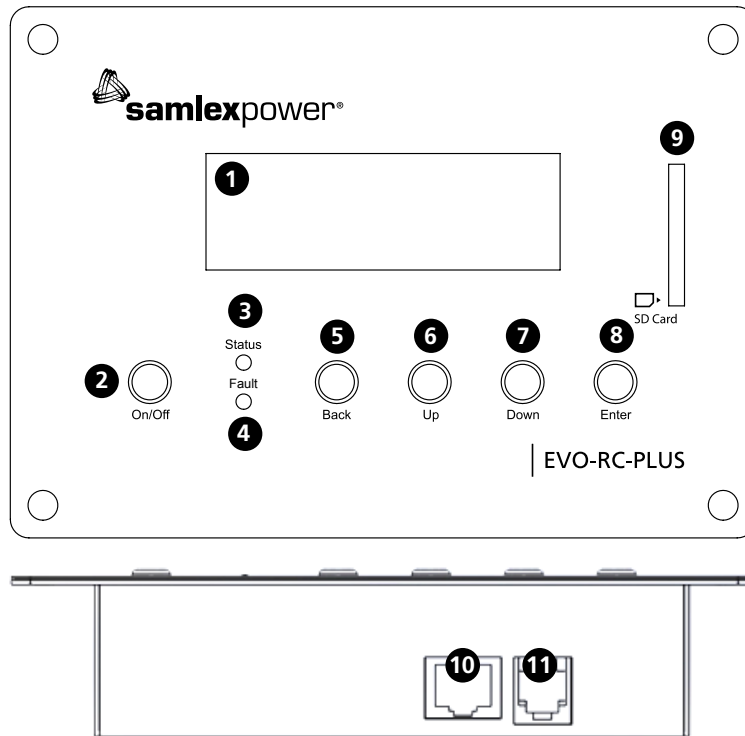

Fig 2.4(a) Optional Remote Control EVO-RC-PLUS

LEGEND for Fig 2.3

1. LCD Screen:
 - 4 rows of 20 characters each
 - Blue screen with white characters
2. ON/OFF Key
3. Blue LED "Status"
4. Red LED "Fault"
5. Navigation Key "Back"
6. Navigation Key "Up"
7. Navigation Key "Down"
8. Navigation Key "Enter"
9. SD Card Slot – FAT16/32 format, up to 16 GB
10. RJ-45 Jack
11. RJ-12 Jack
12. RJ-45 Data Cable (Straight Wired), 10 m / 33 ft [Fig 2.4(b)]

i INFO

Refer to more details under Section 1 of EVO-RC-PLUS Remote Control Manual.



Fig 2.4(b) Cable for Remote Control

SECTION 2 | Components & Layout

2.5 BATTERY TEMPERATURE SENSOR EVO-BCTS [FIG 2.5(a)]

Temperature Sensor [Negative Temperature Coefficient (NTC) resistor]: Mounting hole: 10mm/0.39" suitable for 3/8" or 5/16" battery studs

1. RJ-45 Plug: Pins 1 to 4 → + NTC ; Pins 5 to 8 → – NTC (See pinout of mating RJ-45 Jack at 19, Fig 2.1)
2. 5 meter/16.5 ft cable

Note: Mount the sensor on the Positive or Negative terminal stud on the battery as shown in Fig 2.5(b)



Fig 2.5(a) Temperature Sensor Model EVO-BCTS



Fig 2.5(b) Temperature Sensor Installation

LEGEND for Fig. 2.5(a)

1. Temperature Sensor with Ring Terminal: Mounting hole: 10mm/0.39" suitable for 3/8" or 5/16" battery studs
2. RJ-45 Plug: Plug this into the RJ-45 Jack marked "Battery Temp. Sensor" (6, Fig 2.1). See pinout of mating RJ-45 at Fig 3.13.
3. 5 meter/16.5 ft cable

2.6 CONTENTS OF PACKAGE

- Inverter/Charger
- Temperature Sensor EVO-BCTS [Fig 2.5(a)]
- DC Terminal Covers (1a, 1b: Fig 2.1) (Fitted on the unit with 2 screws each)
- Mating Connector for Remote On/Off Control* (16: Fig 2.1)
- IEC 60320 C-19, Socket Connector**[Mating connector for male AC Power Inlet Plug (9, Fig 2.1)]
- Wire End Terminals for AC Wiring (Fig 3.11) for EVO-1212F-HW/ EVO-1224-HW

Model	AWG#12 (for input wiring)	AWG #14 (for output wiring)
EVO-1212F-HW and EVO-2224-HW	4	4

- Owner's Manual
- Quick Start Guide



* Mating Connector for On/ Off Control (16 Fig 2.1)



** IEC 60320, C-19 Socket Connector (14 Fig 2.1)

SECTION 3 | Installation

3.1 SAFETY OF INSTALLATION



WARNING!

Please ensure safety instructions given under Section 1 are strictly followed.



MISE EN GARDE

Se il vous plaît assurer consignes de sécurité fournies à la section 1 sont strictement suivies.

3.2 OVERALL DIMENSIONS

The overall dimensions and the location of the mounting holes are shown in Fig. 3.1.

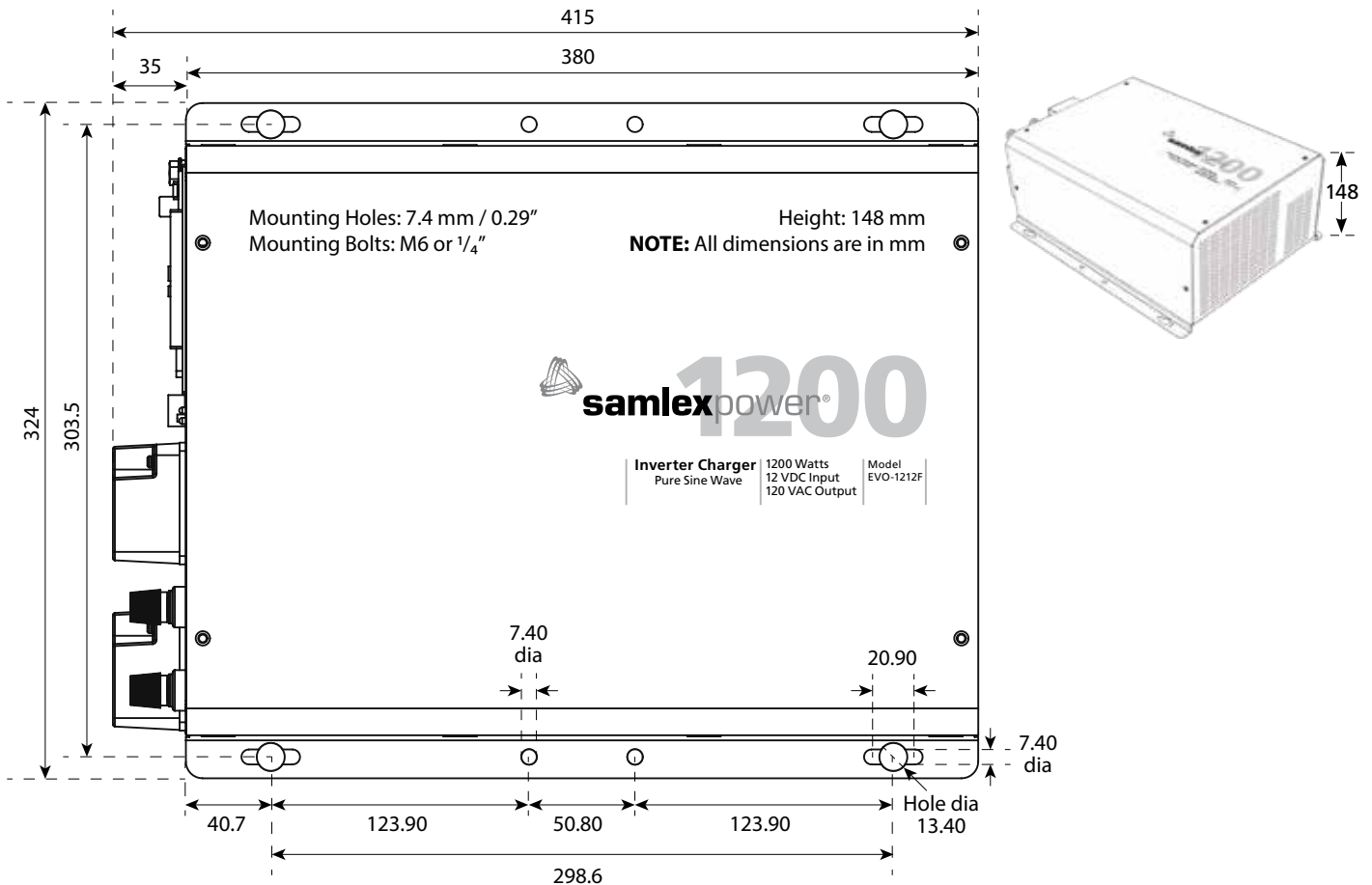

Fig. 3.1 Mounting Dimensions

SECTION 3 | Installation

3.3 MOUNTING OF THE UNIT

In order to meet the regulatory safety requirements, the mounting has to satisfy the following requirements:

- Mount on a non-combustible material
- The mounting surface should be able to support a weight of at least 60 Kg / 132 lbs. Use 4 pcs of 1/4" or M6 mounting bolts and lock washers

Cooling: The unit has openings on the front, bottom and back for cooling and ventilation. Ensure that these openings are not blocked or restricted. Install in cool, dry and well ventilated area.



CAUTION!

Ensure there is **OVER 200 mm** clear space surrounding the inverter for ventilation.



ATTENTION!

Assurer qu'il y a PLUS QUE 200 mm d'espace DÉGAGÉ entourant l'onduleur pour faciliter la ventilation.

Mounting Orientation:

- **Mounting Arrangement 1:**
Mount horizontally on a horizontal surface (e.g. table top or a shelf). Please see Fig. 3.2.

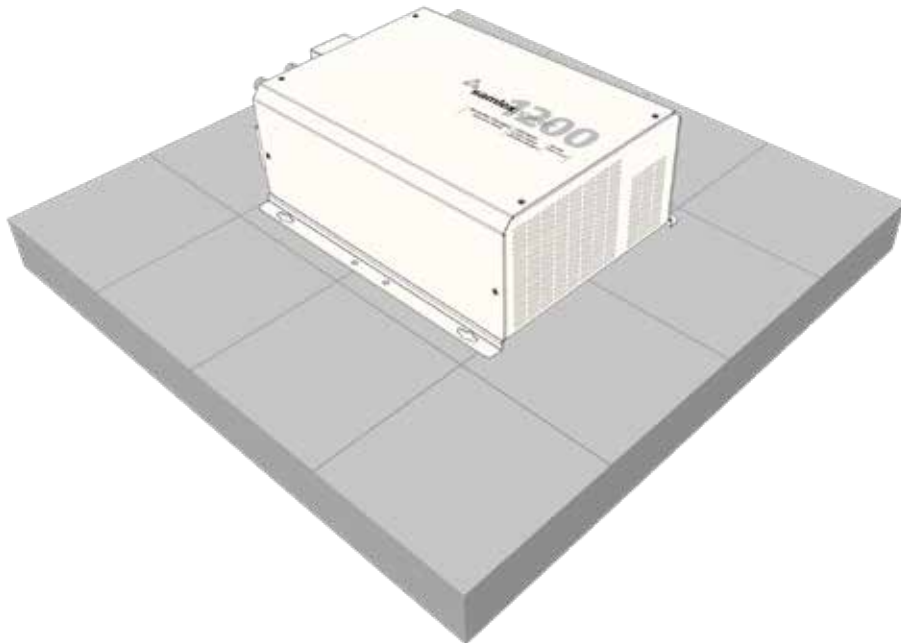

Fig 3.2 Mounting Arrangement No.1: Horizontally On Horizontal Surface

SECTION 3 | Installation

- **Mounting Arrangement No. 2:**

Mount horizontally on a vertical surface (like a wall). Please see Fig. 3.3.

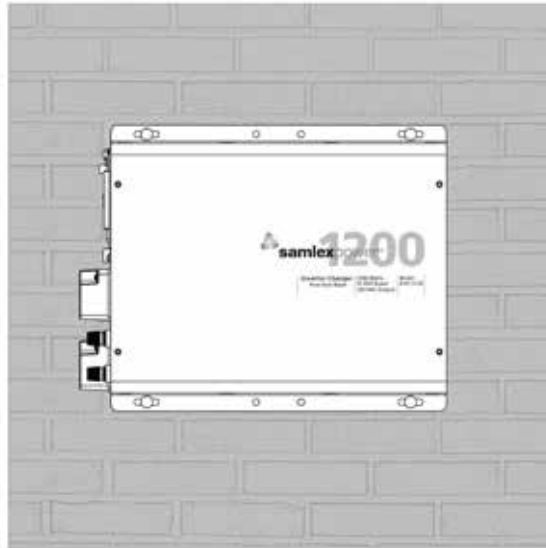

Fig 3.3 Mounting Arrangement 2: On Vertical Surface

- **Mounting Arrangement No. 3:**

Mount vertically on a vertical surface, see Fig. 3.4. Protect against possibility of small objects or water entering the ventilation openings on the top. (If necessary, install a suitable sloping guard at least 200mm from the top surface). Also, ensure there is no combustible material directly under the unit.

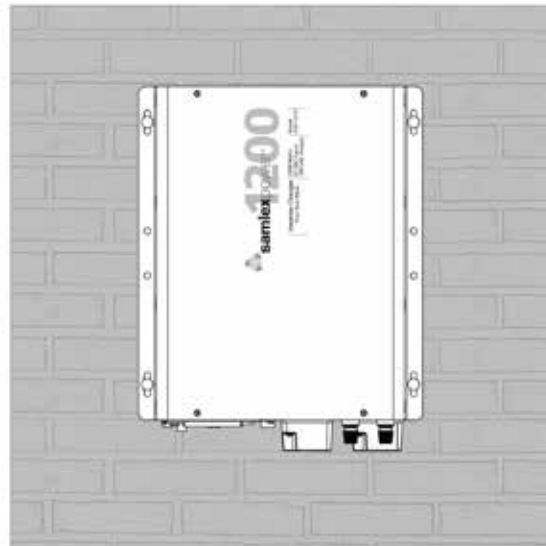

Fig 3.4 Mounting Arrangement 3: On Vertical Surface

SECTION 3 | Installation

3.4 INSTALLING BATTERIES - SERIES AND PARALLEL CONNECTION

Batteries are normally available in voltages of 2V, 6V and 12V and with different Ah capacities. A number of individual batteries can be connected in series and in parallel to form a bank of batteries with the desired increased voltage and capacity.

3.4.1 Series Connection

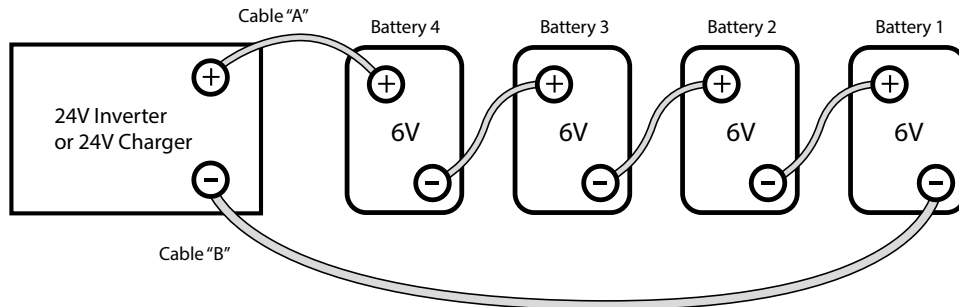

Fig 3.5 Series Connection

When two or more batteries are connected in series, their voltages add up but their Ah capacity remains the same. Fig. 3.5 shows 4 pieces of 6V, 200 Ah batteries connected in series to form a battery bank of 24V with a capacity of 200 Ah. The Positive terminal of battery 4 becomes the Positive terminal of the 24V bank. The Negative terminal of battery 4 is connected to the Positive terminal of battery 3. The Negative terminal of battery 3 is connected to the Positive terminal of battery 2. The Negative terminal of battery 2 is connected to the Positive terminal of battery 1. The Negative terminal of battery 1 becomes the Negative terminal of the 24V battery bank.

3.4.2 Parallel Connection

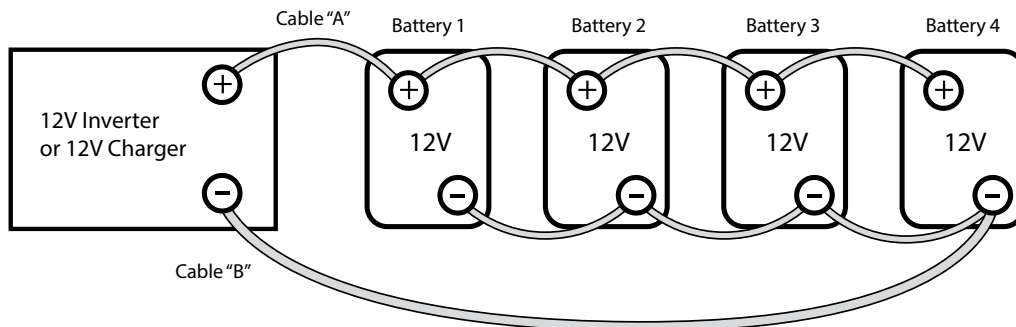

Fig 3.6 Parallel Connection

When two or more batteries are connected in parallel, their voltage remains the same but their Ah capacities add up. Fig. 3.6 above shows 4 pieces of 12V, 100 Ah batteries connected in parallel to form a battery bank of 12V with a capacity of 400 Ah. The four Positive terminals of batteries 1 to 4 are paralleled (connected together) and this common Positive connection becomes the Positive terminal of the 12V bank. Similarly, the four Negative terminals of batteries 1 to 4 are paralleled (connected together) and this common Negative connection becomes the Negative terminal of the 12V battery bank.

SECTION 3 | Installation

3.4.3 Series – Parallel Connection

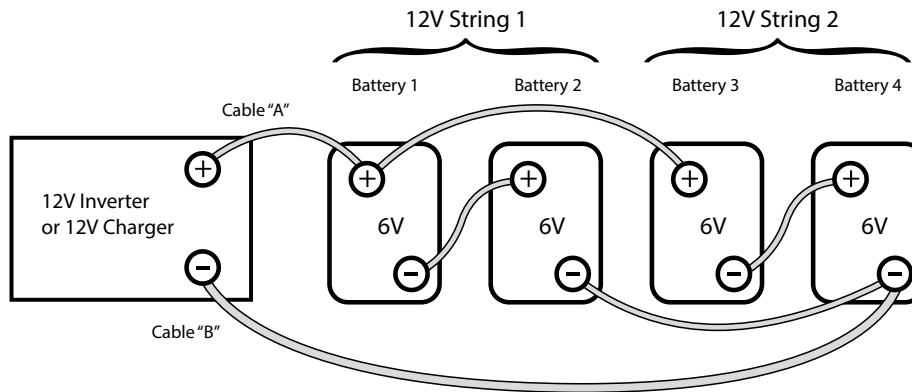

Fig. 3.7 Series-Parallel Connection

Figure 3.7 shows a series – parallel connection consisting of four 6V, 200 Ah batteries to form a 12V, 400 Ah battery bank. Two 6V, 200 Ah batteries, Batteries 1 and 2 are connected in series to form a 12V, 200 Ah battery (String 1). Similarly, two 6V, 200 Ah batteries, Batteries 3 and 4 are connected in series to form a 12V, 200 Ah battery (String 2). These two 12V, 200 Ah Strings 1 and 2 are connected in parallel to form a 12V, 400 Ah bank.

3.4.4 Wiring Order in Parallel Connection of Batteries



CAUTION!

When 2 or more batteries / battery strings are connected in parallel and are then connected to inverter/charger (See Figs 3.6 and 3.7), attention should be paid to the manner in which the inverter/charger is connected to the battery bank. Please ensure that if the Positive output cable of the inverter/charger (Cable "A") is connected to the Positive battery post of the first battery (Battery 1 in Fig 3.6) or to the Positive battery post of the first battery string (Battery 1 of String 1 in Fig. 3.7), then the Negative output cable of the inverter/charger (Cable "B") should be connected to the Negative battery post of the last battery (Battery 4 as in Fig. 3.6) or to the Negative Post of the last battery string (Battery 4 of Battery String 2 as in Fig. 3.7). This connection ensures the following:

- The resistances of the interconnecting cables will be balanced.
- All the individual batteries / battery strings will see the same series resistance.
- All the individual batteries will charge/discharge at the same charging/discharging current and thus, will be charged/discharged to the same state at the same time.
- None of the batteries will see an overcharge/overdischarge condition.

If the Positive output cable of the inverter/charger (Cable "A") is connected to the Positive battery post of the first battery (Battery 1 in Fig. 3.6) or to the Positive battery post of the first battery string (Battery 1 of String 1 in Fig. 3.7), and the Negative output cable of the inverter/charger (Cable "B") is connected to the Negative battery post of the first battery (Battery 1 as in Fig. 3.6) or to the Negative Post of the first battery

SECTION 3 | Installation

string (Battery 1 of Battery String 1 as in Fig 3.7), the following abnormal conditions will result:

- The resistances of the connecting cables will not be balanced.
- The individual batteries will see different series resistances.
- All the individual batteries will be charged/discharged at different charging/discharging current and thus, will reach fully charged/discharged state at different times.
- The battery with lower series resistance will take shorter time to charge/discharge as compared to the battery which sees higher series resistance and hence, will experience over charging/over discharging and its life will be reduced.



ATTENTION!

Quand il y a 2 batteries/fils de batterie ou plus qui sont liés en parallèle et branché à la fois, à un chargeur (Voir Figs. 3.6 et 3.7), il faut faire attention à la manière dont le chargeur est branché à la banque de batterie. Veuillez assurer que le câble positif de sortie du chargeur de batterie (Câble A) est lié à la borne positive de la première batterie (La batterie 1 dans la Fig. 3.6) ou à la borne positive de batterie qui est liée au premier fil (Le fil 1 et la batterie 1, Fig 3.7), et puis le câble négatif de sortie du chargeur de batterie (Câble B) est lié à la borne négative de la dernière batterie (La Batterie 4 dans la Fig. 3.6) ou à la borne négative de batterie qui est liée au dernier fil (Le fil 2 et La batterie 4 dans la Fig. 3.7). Cette connexion assure la suivante:

- *Les résistances des câbles interconnectés seront équilibrées*
- *Tous les batteries/ fils de batterie dans la série auront la même résistance*
- *Toutes les batteries individuelles vont recharger au même courant, ainsi elles seront rechargées à l'état pareille, au même temps*
- *Aucune des batteries auront une condition de surcharge.*

Si le câble positif de sortie du chargeur de batterie (Câble A) est lié à la borne positive de la première batterie (La batterie 1 dans la Fig. 3.6) ou à la borne positive de batterie qui est liée au premier fil (Le fil 1 et La Batterie 1, Fig 3.7), et puis le câble négatif de sortie du chargeur de batterie (Câble B) est lié à la borne négative de la première batterie (La batterie 1 dans la Fig. 3.6) ou à la borne négative de batterie qui est liée au premier fil (Le fil 1 de La Batterie 1 dans la Fig. 3.7), les conditions anormales résulteront:

- *Les résistances des câbles interconnectés seront pas équilibrées*
- *Tous les batteries/ fils de batterie dans la série n'auront pas la même résistance*
- *Toutes les batteries individuelles vont recharger à des courants différentes, ainsi elles atteindront un état de rechargement complet mais en décalage.*
- *La batterie ayant le moins de résistance dans la série prendrait moins de temps pour être rechargée comparé aux autres batteries. Alors elle serait surchargée et, en conséquence aurait une vie plus courte.*

SECTION 3 | Installation

3.5 DC SIDE CONNECTIONS

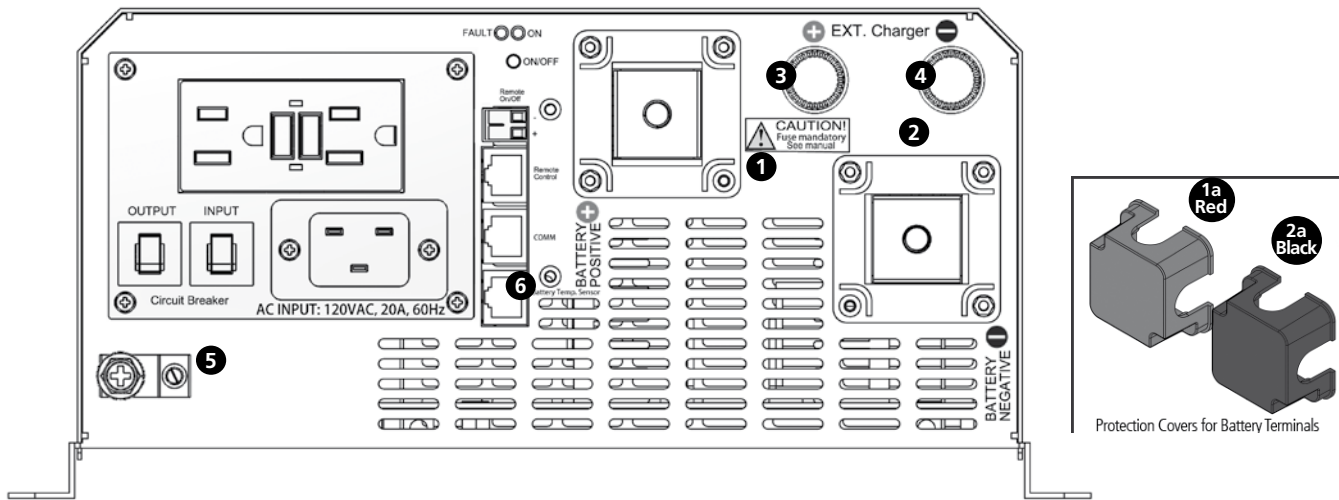

Fig 3.8 D.C Side Connections

LEGEND for Fig 3.8

1. Battery Positive (+) Input Connector (marked "BATTERY POSITIVE"): Stud and Nut, M8 (Pitch 1.25 mm) (RED Protection Cover 1(a) is removed)
 - 1a. RED Protection Cover For Battery Positive (+) Input Connector
2. Battery Negative (-) Input Connector (marked "BATTERY NEGATIVE"): Stud and Nut, M8 (Pitch 1.25 mm) (Black Protection Cover 2(a) is removed)
 - 2a. Black Protection Cover for Battery Negative (-) Input Connector
3. External Charger (+) Input Connector (marked "+ EXT. charger"): Stud and Nut, M6 (Pitch 1 mm)
4. External Charger (-) Input Connector (marked "- EXT. charger"): Stud and Nut, M6 (Pitch 1 mm)
5. DC Side Grounding Connector (marked "⊕") Hole Dia 6.5 mm for up to 25 mm² (AWG #4). Set Screw M-8. This is internally connected to the metal chassis of the unit
6. RJ-45 Jack (marked "Battery Temp. Sensor") is used for 2 functions as follows:
 - a. For input from Temperature Sensor "EVO-BCTS" for temperature compensation when Battery Type 0 = Lead Acid is selected or,
 - b. For input for contact closure / opening signal from the Battery Management System (BMS) to Pins 4 and 5 of the Jack when Battery Type 1 = Lithium is selected. When pins 4 and 5 are shorted due to contact closure, charging will stop in "Charging" Mode and inverting will stop in "Inverting" Mode

3.5.0 Making DC Side Connections

The following DC side connections are required to be made (see Fig 3.8):

- Deep cycle batteries are connected to the battery input terminals (1) and (2). The terminals are provided with protective covers – RED for Positive and BLACK for Negative. Fit these covers once connections have been made. *For general details on sizing and charging of batteries, please refer to Section 1.4 under "General Information-Lead Acid Batteries".*
- Use appropriate external fuse (Refer to Table 3.1) within 7" of battery Positive terminal.
- External charging source, if any, is connected to the connectors (3) and (4) as shown above. **The maximum capacity of the external charging source is 50A.**
- Battery Temperature Sensor EVO-BCTS is connected to the RJ-45 Jack (6). See Fig 2.5 (a) and 2.5 (b) for details.
- DC Side Grounding Connector (5) is connected to the Earth ground / vehicle chassis ground as follows using minimum AWG #6 wire size:
 - (i) to the Bus Bar "G-B" of the DC Electrical Panel (Fig 3.12)
 - (ii) to the Bus Bar "G-B" of the Grid Electrical Panel (Fig 3.13)
 - (iii) to the RV chassis ground in RV (Figs 3.14A and 3.14B)

SECTION 3 | Installation

3.5.1 Preventing DC Input Over Voltage

It is to be ensured that the DC input voltage of this unit does not exceed 17 VDC for the 12V battery version EVO-1212F / EVO-1212F-HW, and 34 VDC for the 24V battery versions EVO-1224F and EVO-1224F-HW to prevent permanent damage to the unit.

3.5.2 Preventing Reverse Polarity On The Input Side



CAUTION!

When making battery connections on the input side, make sure that the polarity of battery connections is correct (Connect the Positive of the battery to the Positive terminal of the unit and the Negative of the battery to the Negative terminal of the unit). If the input is connected in reverse polarity, external DC fuse in the input side will blow and may also cause permanent damage to the inverter.

Damage caused by reverse polarity is not covered by warranty.



ATTENTION!

Au moment de faire les connexions de la batterie sur le côté entrée, assurez-vous que la polarité des connexions de la batterie est correcte (Connecter la borne positive de la batterie à la borne positive de l'unité et la valeur négative de la batterie à la borne négative de l'appareil). Si l'entrée est reliée à l'inversion de polarité, DC externe fusible dans le côté d'entrée fera fondre et peut également causer des dommages permanents à l'onduleur.

Dommages causés par l'inversion de polarité n'est pas couvert par la garantie.

3.5.3 Connection From Batteries / External Charge Controller To The DC Input Side – Sizing of Cables And Fuses



WARNING!

The input section of the inverter has large value capacitors connected across the input terminals. As soon as the DC input connection loop (Battery (+) terminal → Fuse → Positive input terminal of EVO™ → Negative input terminal of the EVO™ → Battery (-) terminal) is completed, these capacitors will start charging and the unit will momentarily draw very heavy current that will produce sparking on the last contact in the input loop even when the unit is in powered down condition.

Ensure that the fuse is inserted only after all the connections in the loop have been completed so that sparking is limited to the fuse area.

SECTION 3 | Installation



MISE EN GARDE!

La section d'entrée de l'onduleur possède une grande valeur condensateurs connectés à travers les bornes d'entrée. Dès que la connexion d'entrée CC (boucle de la batterie (+) → le fusible → la borne d'entrée positive d'EVO → borne d'entrée négative de l'EVO → la batterie (-) est terminée, ces condensateurs va démarrer la charge et l'appareil se tirer momentanément actuelle très lourd qui va produire des étincelles sur le dernier contact de la boucle d'entrée même lorsque l'appareil est en état hors tension.

Assurez que le fusible est insérer seulement après que toutes les connexions sont faites dans le boucle pour que des étincelles se produisent seulement à l'endroit du fusible.

Flow of electric current in a conductor is opposed by the resistance of the conductor. The resistance of the conductor is directly proportional to the length of the conductor and inversely proportional to its cross-section (thickness). The resistance in the conductor produces undesirable effects of voltage drop and heating. The size (thickness / cross-section) of the conductors is designated by AWG (American Wire Gauge). Conductors thicker than AWG #4/0 are sized in MCM/kcmil.

Conductors are protected with insulating material rated for specific temperature e.g. 90°C/194°F. As current flow produces heat that affects insulation, there is a maximum permissible value of current (called "Ampacity") for each size of conductor based on temperature rating of its insulation. The insulating material of the cables will also be affected by the elevated operating temperature of the terminals to which these are connected. Ampacity of cables is based on UL-1741 and the National Electrical Code (NEC)-2014. Please see details given under "Notes for Table 3.1".

The DC input circuit is required to handle very large DC currents and hence, the size of the cables and connectors should be selected to ensure minimum voltage drop between the battery and the inverter. Thinner cables and loose connections will result in poor inverter performance and will produce abnormal heating leading to risk of insulation melt down and fire. Normally, the thickness of the cable should be such that the voltage drop due to the current & the resistance of the length of the cable should be less than 2%. Use oil resistant, multi-stranded copper wire cables rated at 90° C minimum. Do not use aluminum cable as it has higher resistance per unit length. Cables can be bought at a marine / welding supply store.

Effects of low voltage on common electrical loads are given below:

- **Lighting circuits - incandescent and Quartz Halogen:** A 5% voltage drop causes an approximate 10% loss in light output. This is because the bulb not only receives less power, but the cooler filament drops from white-hot towards red-hot, emitting much less visible light.
- **Lighting circuits - fluorescent:** Voltage drop causes a nearly proportional drop in light output.
- **AC induction motors** - These are commonly found in power tools, appliances, well pumps etc. They exhibit very high surge demands when starting. Significant voltage drop in these circuits may cause failure to start and possible motor damage.
- **PV battery charging circuits** - These are critical because voltage drop can cause a disproportionate loss of charge current to charge a battery. A voltage drop greater than 5% can reduce charge current to the battery by a much greater percentage.

SECTION 3 | Installation

3.5.4 Fuse Protection In The Battery Circuit

A battery is an unlimited source of current. Under short circuit conditions, a battery can supply thousands of Amperes of current. If there is a short circuit along the length of the cables that connects the battery to the inverter, thousands of Amperes of current can flow from the battery to the point of shorting and that section of the cable will become red-hot, the insulation will melt and the cable will ultimately break. This interruption of very high current will generate a hazardous, high temperature, high-energy arc with accompanying high-pressure wave that may cause fire, damage nearby objects and cause injury. To prevent occurrence of hazardous conditions under short circuit conditions, the fuse used in the battery circuit should limit the current (**should be "Current Limiting Type"**), blow in a very short time (**should be Fast Blow Type**) and at the same time, quench the arc in a safe manner. For this purpose, **UL Class T fuse or equivalent** should be used (**As per UL Standard 248-15**). This special purpose current limiting, very fast acting fuse will blow in less than 8 ms under short circuit conditions. **Appropriate capacity of the above Class T fuse or equivalent should be installed within 7" of the battery Plus (+) Terminal (Please see Table 3.1 for fuse sizing).**

Marine Rated Battery Fuses, MRBF-xxx Series made by Cooper Bussmann may also be used. These fuses comply with ISO 8820-6 for road vehicles.



WARNING!

It is mandatory to use appropriately sized external fuse in the battery and External Charger Circuits. If external fuse is not used and reverse polarity connection is made by oversight, the input section of the unit will be damaged/burnt. **Warranty will be voided in such a situation.**



MISE EN GARDE!

*Il est obligatoire d'utiliser un fusible externe de taille appropriée à la batterie et les circuits chargeur externe . Si le fusible externe est pas utilisé et les inversions de polarité est faite par la surveillance , la section d'entrée de l'unité est endommagée / brûlé . **La garantie sera annulée dans une telle situation.***

3.5.5 DC Input Connection for Battery

Battery is connected to terminals 1, 2 shown in Fig 3.8. The terminal consists of M10 Stud & Nut. Tightening torque for the nut is 70 kgf.cm (5 lbf.ft). **Sizes of cables and fuses are shown in Table 3.1.** Sizing is based on safety considerations specified in UL-1741 and NEC-2014. See details under "Notes for Table 3.1".

3.5.6 DC Input Connection for External Solar Charge Controller

External charger is connected to terminals consisting of M12 Stud with Thumb Nut (3, 4 in Fig. 5.8).

External charger is connected to terminals consisting of M6 Stud (Pitch 1 mm) with Thumb Nut (3, 4 in Fig. 3.8).

- Max current fed through these terminals should be < 50A
- Use wire size given in Table 3.1.
- Tightening torque for the Thumb Nut is 35 kgf.cm (2.5 lbf.ft)
- Use 70A fuse in series with the Positive wire to protect against short circuit along the length of the connecting wires.
Fuse should be close to the Positive Input Terminal 3.
- Please refer to Section 5.4 for details of charging using external solar charge controller.

SECTION 3 | Installation

TABLE 3.1 SIZING OF BATTERY SIDE CABLES AND EXTERNAL BATTERY SIDE FUSES							
Model No. (Column 1)	Rated Continuous DC Input Current (See Note 1) (Column 2)	NEC Ampacity = 125% of Rated DC Input Current at Column 2 (See Note 2) (Column 3)	90°C Copper Conductor. Size Based on NEC Ampacity at Column (3) or 2% Voltage Drop, whichever is Thicker (See Note 3)				External Fuse Based on NEC Ampacity at Column (3) (See Note 4) (Column 8)
			Cable Running Distance between the Unit and the Battery (Cable Routing In Free Air)		Cable Running Distance between the Unit and the Battery (Cable Routing In Raceway)		
			Up to 5 ft. (Column 4)	Up to 10 ft. (Column 5)	Up to 5 ft. (Column 6)	Up to 10 ft. (Column 7)	
EVO-1212F	152	190	AWG #2	AWG #2/0	AWG #2/0	AWG #2/0	200A
EVO-1212F-HW							
EVO-1224F	76	95	AWG#6	AWG#4	AWG#3	AWG#3	100A
EVO-1224F-HW							
External Charger	50A	63A	AWG #6 (2% voltage drop is thicker)	AWG #2 (2% voltage drop is thicker)	AWG #6	AWG #2 (2% voltage drop is thicker)	70A

NOTES FOR TABLE 3.1 - SIZING OF BATTERY SIDE CABLES AND EXTERNAL BATTERY SIDE FUSES

- 1) Column 2 indicates the Rated Continuous DC Input Current drawn from the battery in Inverter Mode
- 2) Column 3 indicates NEC Ampacity based on which cable conductor sizes (Columns 4 to 7) are determined. NEC Ampacity is not less than 125% of the Rated Continuous DC Input Current (Column 2) - Refer to NEC-2014 (National Electrical Code) - Section 215.2(A)(1)(a) for Feeder Circuits.
- 3) Columns 4 to 7 indicate cable conductor size that is based on the following 2 considerations. Thicker conductor out of the following 2 considerations has been chosen:
 - a) As per guidelines in NEC-2014 (National Electrical Code) - Ampacity Table 310.15(B)(16) for Raceway and Ampacity Table 310.15(B)(17) for Free Air. Conductor size is based on (i) NEC Ampacity specified at Column 3, (ii) Copper conductor with temperature rating of 90°C and (iii) Ambient temperature of 30°C / 86°F
 - b) Voltage drop across the length of cables has been limited to 2% of 12V / 24V. Voltage drop has been calculated by multiplying the Rated DC Input Current (Column 2) and the resistance of the total length of Copper conductor (the total length of conductor has been taken as 2 times the running distance between the unit and the battery to cover 2 lengths of Positive and Negative cable conductors).
- 4) Column 8 indicates the size of external fuse in the battery circuit. It is mandatory to install this fuse within 7" of the battery Positive terminal to protect the internal DC Input Section of the unit and also to protect the battery cables against short circuit. Ampere rating of the fuse is based on the following considerations:
 - a) The Ampere rating of the fuse is not less than NEC Ampacity of 125% of the Rated Continuous DC Input Current (Column 3) - Refer to NEC-2014 (National Electrical Code) - Section 215.3
 - b) Standard Ampere Rating of Fuse equal to the above NEC Ampacity of 125% of the Rated DC Input Current has been used - Refer to NEC-2014 (National Electrical Code) - Section 240.6(A)
 - c) Where Standard Fuse Rating does not match the required Ampacity of 125% of the Rated Continuous DC Input Current (Column 3), the next higher Standard Rating of the fuse has been used - Refer to NEC-2014 (National Electrical Code) - Section 240.4(B)
 - d) Type of fuse: Fast-acting, Current Limiting, UL Class T (UL Standard 248-15) or equivalent

SECTION 3 | Installation

3.5.7 Using Proper DC Cable Termination

The battery end and the inverter end of the wires should have proper terminal lugs that will ensure a firm and tight connection. Choose lugs to fit the wire size and the stud sizes on the inverter and battery ends.

Tightening torques to be applied to the wiring terminals are given in Table below:

TIGHTENING TORQUES		
Battery Input Connectors	External Charger Input Connectors	AC Input and Output Connectors
70 kgf.cm (5.0 lbf.ft)	35 kgf.cm (2.5 lbf.ft)	7 to 12 kgf.cm (0.5 to 0.9 lbf.ft)

3.5.8 Reducing RF Interference

To reduce the effect of radiated interference, shield the wires with sheathing / copper foil / braiding. For details, refer to "Limiting Electro-Magnetic Interference" at Section 1.3.4.

3.5.9 Taping Battery Wires Together To Reduce Inductance

Do not keep the battery wires far apart. Keep them taped together to reduce their inductance. Reduced inductance of the battery wires helps to reduce induced voltages. This reduces ripple in the battery wires and improves performance and efficiency. For details, refer to "Limiting Electro-Magnetic Interference" at Section 1.3.4.

3.6 AC INPUT AND OUTPUT - LAYOUT AND CONNECTION ARRANGEMENT

3.6.1 AC Input and Output Connections for EVO-1212F and EVO-1224F

3.6.1.1 AC Input Connection: Grid AC input is fed through 20A AC Inlet Plug Connector – IEC60320 C-20 (9, Fig 3.9.1). Use NEMA 20A-125 VAC detachable Power Cord [NEMA5-20 Plug for connecting to the 120VAC Outlet and IEC60320 C-19 Socket Connector on the other end for connection to the Inlet Plug Connector (9, Fig 3.9.1)]. **For convenience, IEC60320 C-19 socket connector has been provided. (See Section 2.6 - Contents of Package).**

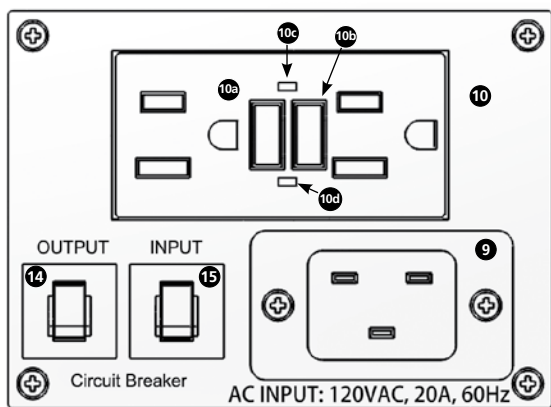

LEGEND for Fig 3.9.1

- 9. 20A AC Inlet Connector – IEC60320 C-20 for connecting detachable AC power cord for 120 VAC input from Grid
- 10. NEMA5-15 Duplex GFCI Outlets for 120 VAC output
 - 10a. GFCI Test Button
 - 10b. GFCI Reset Button
 - 10c. Red LED: GFCI Life and End Alarm
 - 10d. Green LED: GFCI ON
- 14. AC output Breaker, 15A
- 15. AC Input Breaker, 20A

Fig 3.9.1 AC Input and Output Connections – EVO-1212F and EVO-1224F

SECTION 3 | Installation

3.6.1.2 AC Output Connection Through Ground Fault Circuit Interrupter (GFCI)

An un-intentional electric path between a source of current and a grounded surface is referred to as a "Ground Fault". Ground faults occur when current is leaking somewhere. In effect, electricity is escaping to the ground. How it leaks is very important. If your body provides a path to the ground for this leakage (dry human body has a low resistance of only around 1 K Ohm), you could be injured, burned, severely shocked or electrocuted. A Ground Fault Circuit Interrupter (GFCI) protects people from electric shock by detecting leakage and cutting off the AC source. The leakage detection circuit compares the current sent to the load and returned back from the load. If the returned current is less by 5 to 6 mA due to leakage, the GFCI trips. The GFCI also trips if it sees Neutral to Ground bond on the load side of the GFCI.

The AC output of EVO-1212F and EVO-1224F is available through a NEMA5-15R GFCI Duplex Receptacle (10 in Figs 2.1 and 3.9.1). The Neutral slot of this receptacle (longer rectangular slot) is internally bonded to the metal chassis of the inverter.

Self Monitoring GFCI: The GFCI is "Self Monitoring Type" as per UL Standard UI-943. As soon as the Inverter is switched ON and 120 VAC is available on the internal Line Side of the GFCI, Red LED marked "Life End Alarm" (10c in Figs 2.1 and 3.9.1) will flash once and then will remain OFF. The Green LED (10d in Figs 2.1 and 3.9.1) will switch ON indicating that AC power is available at the Load Side outlets.

As soon as the Inverter is switched OFF and 120 VAC is removed from the internal Line Side of the GFCI, Red LED marked "Life End Alarm" (10c in Figs 2.1 and 3.9.1) will flash once and then will remain OFF. The Green LED (10d in Figs 2.1 and 3.9.1) will switch OFF indicating that AC power is NOT available at the Load Side outlets.

The Self Monitoring Function inside the GFCI will monitor proper operation of ground fault protection circuitry every 1 to 10 minutes. If defect in the ground fault protection circuit is detected, the Red LED marked "Life End Alarm" (10c in Figs 2.1 and 3.9.1) will remain ON and the GFCI will have to be replaced.

Monthly Testing of GFCI: Test the operation of the GFCI monthly as follows:

- Switch ON the inverter. As soon as 120 VAC output from the inverter is available on the internal Line Side of the GFCI, Red LED marked "Life End Alarm" (10c in Figs 2.1 and 3.9.1) will flash once within 5 sec and then will remain OFF. The Green LED (10d in Figs 2.1 and 3.9.1) will switch ON indicating that AC power is available at the Load Side outlets.
- Plug a test lamp into the outlet and switch ON the test lamp.
- Press the "Test Button" (10a in Figs 2.1 and 3.9.1). The "Reset Button" (10b in Figs 2.1 and 3.9.1) will pop out. The GFCI will be forced to trip and cut off AC power to the load side outlets. Green LED (10d in Figs 2.1 and 3.9.1) will switch OFF. The test lamp will also switch OFF.
- Press the "Reset Button" (10b in Figs 2.1 and 3.9.1). The GFCI will reset and AC power to the load side outlets will be restored. Green LED (10d in Figs 2.1 and 3.9.1) will switch ON. The test lamp will also switch ON.
- If the above Test / Reset operation cannot be carried out, replace the GFCI.

GFCI Tripping and Reset: If there is a leakage of 5 to 6mA due to ground fault on the load side or, there is a Neutral to Ground bond on the load side, the GFCI will trip and the "Reset Button" (10b in Figs 2.1 and 3.9.1) will pop out. AC power to the load side outlets will be cut off. Green LED (10d in Figs 2.1 and 3.9.1) will switch OFF. Remove the ground fault in the load circuit. Press the "Reset Button" (10b in Figs 2.1 and 3.9.1). The GFCI will reset and AC power to the load side outlets will be restored. Green LED (10d in Figs 2.1 and 3.9.1) will switch ON.

SECTION 3 | Installation

i INFO

For the Reset Button (10b in Figs 2.1 and 3.9.1) to operate, the Inverter has to be in ON condition so that AC power is available to the internal Line Side of the GFCI.



CAUTION!

1. Do not feed the output from the GFCI receptacle to a Panel Board / Load Center where the Neutral is bonded to the Earth Ground. This will trip the GFCI.
2. If an extension cord is used, please ensure that the cord is 2-Pole Grounding Type (3 pin).



ATTENTION!

1. N'alimentent pas la sortie de la prise GFCI à un Panel de sélection / Charger Centre où la position neutre est lié à la terre. Ce qui déclenche le disjoncteur.
2. Si une rallonge est utilisée, veuillez vous assurer que le cordon est mise à la terre à 2 pôles (3 broches)

3.6.2 AC Input and Output Connections and Layout Arrangement for EVO-1212F-HW and EVO-1224F-HW

AC input and output connections for EVO-1212F-HW and EVO-1224F-HW are shown in Figs 3.9.2(a) and 3.9.2(b) below. (Extracted from the layout at Fig 2.3).

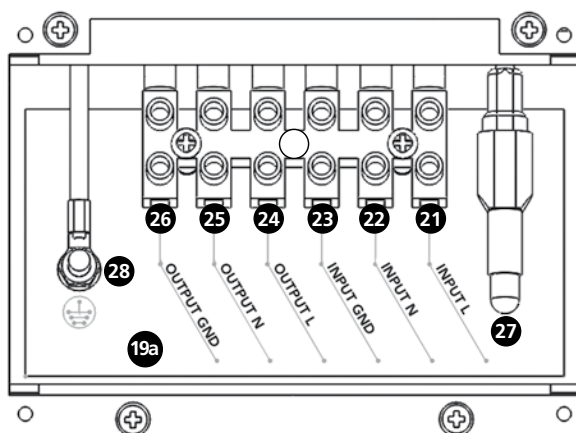

Fig 3.9.2(a) Pocket for AC Input and Output Connections for EVO-1212F-HW and EVO1224F-HW

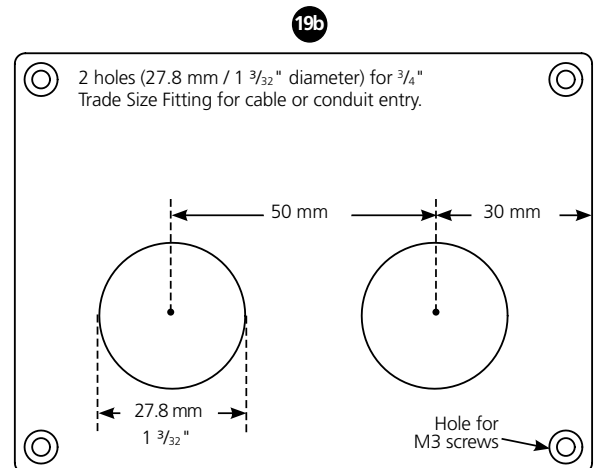

Fig 3.9.2(b) Cover Plate for Pocket for AC input and Output Connections

SECTION 3 | Installation

LEGEND for Figs 3.9.1(a) and 3.9.1(b)

- 19(a). Pocket for AC Input/Output Terminals
- 19(b). Plate to cover pocket 19(a) - The plate is held with 4 mounting screws - M3 (Pitch 0.5 mm) x 6 mm. The plate has 2 holes (27.8 mm/ 1 3/32" diameter) for 3/4" Trade Size Fitting for cable or conduit entry.
- 20. AC Input/Output Terminal Block
 - Terminal hole: 3.5 mm x 3.0 mm for up to AWG #10
 - Set Screw: M3 (Pitch 0.5 mm)
- 21. "INPUT L" - For connecting Line Conductor of AC input wiring
- 22. "INPUT N" - For connecting Neutral Conductor of AC input wiring
- 23. "INPUT GND" - For connecting Earth Ground Conductor of AC input wiring
- 24. "OUTPUT L" - For connecting Line Conductor of output wiring to Electrical Panelboard
- 25. "OUTPUT N" - For connecting Neutral Conductor of output wiring to Electrical Panelboard
- 26. "OUTPUT GND" - For connecting Earth Ground Conductor of output wiring to Electrical Panelboard
- 27. Male/Female Insulated Quick Disconnect for disabling Output Neutral to chassis Ground bond in Inverter Mode (Please see Sections 4.4.1 / 4.4.2 and Fig 4.1)
- 28. AC input and output Ground connection to metal chassis - Stud and Nut, M4 (Pitch 0.7 mm)

3.6.3 System Grounding and Output Neutral to Chassis Ground Bond Switching



WARNING!

- In "Inverting Mode" (default condition), the Neutral of the AC output of the unit gets bonded to the metal chassis of the unit through the internal "Neutral to Chassis Switching Relay" [Relay RY2 in Fig 4.1].
- In "Charging Mode", the internal "Output Neutral to Chassis Switching Relay - RY2" disconnects the Neutral of the AC output connection from the chassis of the unit. The Neutral of the AC output connection of the unit will get bonded to the Earth Ground through the Neutral to Earth Ground bond in the AC Breaker Panel/Load Center supplying Grid power / AC output connections of the generator.
- **Disabling Neutral to Ground Bond:** In some applications, the Output Neutral may be required to remain isolated from chassis/Ground at all times. For this, automatic Output Neutral to chassis Ground bond can be disabled by disconnecting the Insulated Male/Female Quick Disconnect [27, Fig 3.9.2(a)] located in the AC Wiring Compartment in EVO-1212F-HW/1224F-HW. **In EVO-1212F/1224F, this Insulated Male/Female Quick Disconnect is accessible after opening the top cover of the unit.**
- System grounding, as required by National / Local Electrical Codes / Standards, is the responsibility of the user / system installer.

For further details please refer to Sections 4.4.1/ 4.4.2 and Fig 4.1.

SECTION 3 | Installation



MISE EN GARDE!

- *En état de défaut, le neutre de la sortie CA de l'unité dans le "Mode de l'onduleur / décharge" obtient lié au châssis métallique de l'unité à travers la interne "Neutre à châssis relais de commutation" (RY2 Relais de la figure 4.1)*
- *Dans "Mode de chargement", l'interne "Neutre à châssis relais de commutation - RY2" déconnecte le neutre de la connexion de sortie AC du châssis de l'unité. Le neutre de la connexion de sortie CA de l'unité va obtenir lié à la terre des masses à travers le neutre à la terre liaison au sol dans le centre de panneau de disjoncteurs AC / charge alimenter Grille / connexions de sortie CA du générateur.*
- **Désactivation du lien neutre à mise a terre:** *Dans certaines applications, il est nécessaire que la sortie neutre soit isolé du châssis/mise a terre à tout moment. Pour cela, la production automatique de la position neutre à la masse du châssis bon peut être désactivé en déconnectant le mâle/femelle isolée [Déconnexion rapide, 27 Fig 3.9.2(a)] situé dans le compartiment de câblage AC dans **EVO-1212F-HW/1224F-HW**. Dans **EVO-1212F/1224F**, ce mâle/femelle isolée est accessible à déconnexion rapide après l'ouverture du capot de l'unité.*
- *Mise à la terre du système, tel que requis par la National / codes électriques locaux / normes, est de la responsabilité de l'installateur utilisateur / système.*

3.6.4 AC Input Considerations – Voltage And Frequency

The EVO™ unit is designed to accept 120 VAC, 60 Hz single phase AC power from Grid or from good quality Generator with stable 120 VAC / 60 Hz output. These 120V versions come preset for 60 Hz operation.

3.6.5 Preventing Paralleling of the AC Output



WARNING!

The AC output of the unit cannot be synchronized with another AC source and hence, it is not suitable for paralleling on the output side. The AC output of the unit should never be connected directly to an electrical breaker panel / load center which is also fed from another AC source. Such a connection may result in parallel operation of different power sources and AC power from the other AC source will be fed back into the unit which will instantly damage the output section of the unit and may also pose a fire and safety hazard. If an electrical breaker panel / load center is fed from this unit and this panel is also required to be powered from additional alternate AC source, the AC power from the additional AC source should first be fed to a suitable Manual/Automatic Transfer Switch and the output of the transfer switch should be connected to the electrical breaker panel / load center. To prevent possibility of paralleling and severe damage to the inverter, never use a simple jumper cable with a male plug on both ends to connect the AC output of the inverter to a handy wall receptacle in the home / RV.

SECTION 3 | Installation



MISE EN GARDE!

La sortie de courant alternatif de l'unité ne peut pas être synchronisée avec une autre source de courant alternatif et, par conséquent, il ne convient pas pour mise en parallèle du côté de la sortie. La sortie AC de l'unité ne doit jamais être connectée directement à un panneau central / de charge disjoncteur électrique qui est également alimenté par une autre source de courant alternatif. Une telle connexion peut entraîner un fonctionnement parallèle de différentes sources d'énergie et la puissance AC de l'autre source de courant alternatif est réinjecté dans l'unité qui va instantanément endommager la section de sortie de l'unité et peuvent aussi poser un risque d'incendie et de sécurité. Si un centre panneau de disjoncteur électrique / charge est alimentée à partir de cette unité et ce panneau est également nécessaire pour être alimenté à partir de suppléant supplémentaire source de courant alternatif, l'alimentation de la source de courant alternatif supplémentaire doit d'abord être introduit dans un manuel approprié / commutateur de transfert automatique et le sortie du commutateur de transfert doit être relié au centre panneau / de la charge électrique du disjoncteur. Pour éviter possibilité de mise en parallèle et de graves dommages à l'onduleur, ne jamais utiliser un câble de raccordement simple avec une fiche mâle sur les deux extrémités pour raccorder la sortie AC de l'onduleur à une prise murale à portée de main à la maison / RV.

3.6.6 Connecting to Multi-wire Branch Circuits

Do not directly connect the hot side of the 120 VAC of the unit to the two Hot Legs of the 120 / 240 VAC Breaker Panel / Load Center where Multi-wire (common Neutral) Branch Circuit wiring method is used for distribution of AC power. This may lead to overloading / overheating of the neutral conductor and is a risk of fire.

A split phase transformer (Isolated or Auto-transformer) of suitable VA rating (25 % more than the VA rating of the unit) with Primary of 120 VAC and Secondary of 120 / 240 VAC (Two 120 VAC split phases 180 degrees apart) should be used. The Hot and Neutral of the 120 VAC output of the inverter should be fed to the Primary of this transformer and the 2 Hot outputs (120 VAC split phases) and the Neutral from the Secondary of this transformer should be connected to the Electrical Breaker Panel / Load Center.

Please see details on-line under White Paper titled "120 / 240 VAC Single Split Phase System and Multi-wire Branch Circuits" at: www.samlexamerica.com (Home > Support > White Papers).

3.7 AC INPUT & OUTPUT WIRING SUPPLY CONNECTIONS

3.7.1 AC Input/Output Supply Connections for EVO-1212F and EVO-1224F

120 VAC input is fed through Male AC Power Inlet Plug - Rating 20A (IEC 60320 C-20) (9, Fig 2.1). Mating Female Socket Connector rated for 20A (IEC 60320 C-19) will be required. For convenience, this Connector has been supplied with the unit (See Section 2.6 - "Contents of Package"). The AC input connector is protected against over-current by 20A Circuit Breaker (15, Fig 2.1).

120 VAC output is supplied through NEMA5-15 Duplex GFCI Outlets (10, Fig 2.1). The outlets are protected against over current by 15A Circuit Breaker (14, Fig 2.1).

SECTION 3 | Installation

3.7.2 AC Input / Output Supply Connectios – EVO-1212F-HW / EVO-1224F-HW



WARNING!

Please ensure that when using the hard-wired version EVO-1212F/1224F-HW, the AC input is connected to the AC input terminals and not to the AC output terminals and that this connection is made only when the unit is in off condition.

Please note that when the unit is powered on, a Self Test is carried out which includes a check if the AC input conductors have been erroneously connected to the AC output terminals instead of AC input terminals. If this wrong connection is detected, (voltage > 10 VAC is seen on terminals OUTPUT L & OUTPUT N at the time of switching on of the unit), the unit will not be powered on and a message "Output Fault" will be displayed. This protection against error in connection of the AC input wiring is active only when this wrong connection is made when the unit is in off condition and is switched on subsequently.

If the AC input is erroneously connected / fed to the AC output connections when the unit is ON condition, the above protection will not work and the Inverter Section will be burnt instantaneously and may become a fire hazard.



MISE EN GARDE!

Veillez vous assurer que lors de l'utilisation de la version filaire EVO-1212F/1224F-HW, l'entrée CA est connecté à l'entrée aux bornes et non pas à l'AC bornes de sortie et que cette connexion est effectuée uniquement lorsque l'appareil est en position d'arrêt.

Lorsque l'unité est sous tension, un test automatique est effectué qui inclut une vérification si l'entrée CA par erreur ont été conducteurs connectés à l'AC les terminaux de sortie au lieu d'AC les bornes d'entrée. Si cette erreur est détectée, (tension > ; 10 VAC est perçu sur les bornes OUTPUT L & ; SORTIE N au moment de la mise en marche de l'unité), l'appareil ne sera pas mis sous tension et un message "Défaut de sortie" s'affiche. Cette protection contre l'erreur lors de la connexion de l'entrée CA câblage est actif seulement quand cette mauvaise connexion est établie lorsque l'appareil est en position d'arrêt et est activée par la suite.

Si l'entrée CA est connecté par erreur / nourri à l'AC de sortie lorsque l'appareil est en état, la protection ci-dessus ne fonctionnera pas et la Section de l'onduleur sera brûlé instantanément et peut devenir un risque d'incendie.

The AC input and output supply connections are located in a pocket protected by a cover with a removable front plate [19(a), Fig 3.9.2(a) and 19(b), Fig 3.9.2(b)]. Two 27.8 mm / 13/32" diameter holes [19(b), Fig 3.9.2(b)] have been provided for cable / conduit entry. Remove the caps covering the holes and install appropriate ¾" Trade Size Fitting for routing the AC input and output wires/conduits.

Screw down type of terminal block [20, Fig 3.9.2(a)] is used for connecting the wires. The hole size for wire entry is 3.5 x 3 mm and set screw size is M3. It can accommodate conductors with solid or multi-stranded wire size range of

SECTION 3 | Installation

up to AWG #10. Strip adequate insulation from the end of the wire (Fig. 3.11). Avoid nicking the wire when stripping the insulation. Wire End Terminals have been provided (see Section 2.6, "Contents of Package") for firm connection under the set screw. Insert the bare end of the wire into the barrel portion of the Wire End Terminal & crimp barrel portion using suitable crimping tool (Fig 3.11). Use #12 AWG terminals for AWG #12 wiring for AC input and AWG #14 terminals for AWG #14 wiring for AC output. Insert the terminated end of the wire fully into the terminal slot till it stops. Tighten the screw firmly. Tightening torque for the screws – 7 to 12 Kgf*cm / 0.5 to 0.9 lbf*ft.

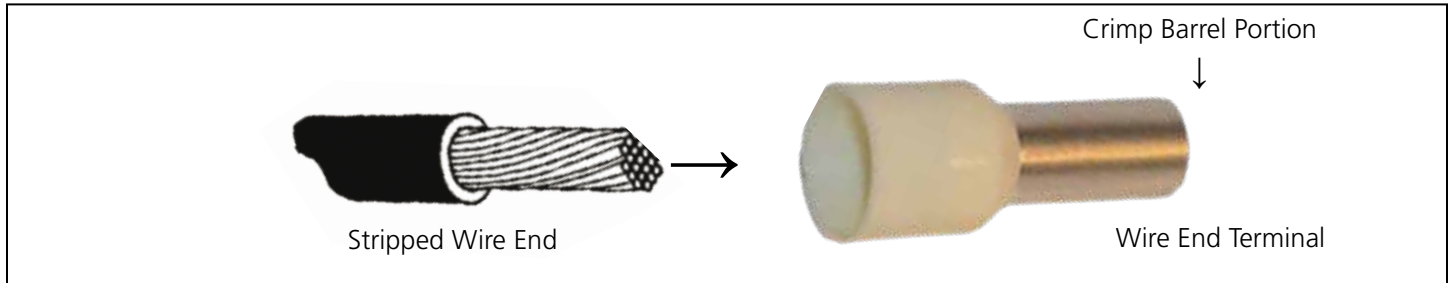

Fig 3.11 Stripped Wire End Terminal on AC Wiring

3.8 SIZING OF WIRING AND BREAKERS - AC INPUT SIDE



WARNING!

For EVO-1212F-HW/ 1224F-HW, AC Breaker for the AC input circuits has NOT been provided internally. This has to be provided externally by the installer / user based on guidelines given below. Please note that guidelines given below on wire sizing and over-current protection will be superseded by the applicable National / Local Electrical Codes.



MISE EN GARDE!

Pour EVO-1212F-HW/ 1224F-HW, Breaker AC pour les circuits d'entrée AC ont pas été fournis en interne. Cela doit être fournie en externe par l'installateur / utilisateur en fonction des directives données ci-dessous. Se il vous plaît noter que les directives ci-dessous sur dimensionnement des câbles et protection contre les surintensités seront remplacées par les nationaux / codes électriques locaux applicables.

3.8.1 Table for Wire and Breaker Sizing - AC Input Side

Table 3.2 provides details of wire and breaker sizing for the AC input side.

AC input side wiring and breaker sizes depend upon the maximum continuous AC input current under various operating conditions described in the succeeding paragraphs.

- When Grid input is available and the unit is operating in Charging / Pass Through Mode, the AC Input Current will be determined as follows:
 - AC Input Current will be equal to the sum of the AC Side Battery Charging Current and the Pass Through current.

SECTION 3 | Installation

- The AC Input current in Charging / Pass Through Mode will be restricted by the breaker in the AC Input Branch Circuit that is feeding the unit. The AC Input Current drawn by the unit can be programmed to the desired "GRID MAX CURRENT" to match the Amp rating of breaker in the AC Input Branch Circuit. Optional Remote Control EVO-RC-PLUS is required to change this limit [See EVO-RC-PLUS Manual: (i) Fig 4.3, Screen 2 (ii) Table 4.4 Screen 2 and (ii) Section 4.5.2.2]. The "GRID MAX CURRENT" set at 20A (Default Setting).

TABLE 3.2 SIZING OF AC INPUT WIRING AND BREAKERS				
Model No. (Rated Output Power in Inverter Mode)	Current Rating of AC Input Breaker (15, Fig 2.1) (See Note 2)	NEC Ampacity = 125% of Column 2 (See Note 3)	Conductor Size Based on NEC Ampacity at Column 3 (See Note 4)	Size of Breaker based on Column 4 (See Note 5)
(Column 1)	(Column 2)	(Column 3)	(Column 4)	(Column 5)
EVO-1212F (1200VA, 10A)	20A	25A	AWG #12	20A
EVO-1212F-HW (1200VA, 10A)	20A	25A	AWG #12	20A
EVO-1224F (1200VA, 10A)	20A	25A	AWG #12	20A
EVO-1224F-HW (1200VA, 10A)	20A	25A	AWG #12	20A

NOTES FOR TABLE 3.2 - SIZING OF GRID AND BREAKERS

- Column 1 indicates the Model No. & output power (VA) & current (A) in Inverter Mode.
- Column 2 indicates the Maximum AC Input Current of 20A which is equal to 20A rating of AC input breaker (15, Fig 2.1)
- Column 3 indicates NEC Ampacity based on which the wiring conductor size (Column 4) is determined. This NEC Ampacity is not less than 125% of the maximum input current (Column 2) - Refer to NEC-2014 (National Electrical Code) - Section 210.19(A)(1)(a) regarding minimum Ampacity and size of Branch Circuit Conductors.
- For EVO-1212F-HW and EVO-1224F-HW:** Column 4 indicates the wiring conductor size that has been determined based on NEC-2014 (National Electrical Code) - Ampacity Table 310.15(B)(16) for Raceway for EVO-1212F and EVO-1224F-HW. This conductor size is based on (i) NEC Ampacity (Column 3) (ii) conductor temperature of 75°C / 167°F and (iii) ambient temperature of 30°C / 86°F.
 - For EVO-1212F and EVO-1224F:** Power may also be supplied through NEMA rated 20A-125V detachable Power Cord (3 conductors, AWG #12) for free air - Ampacity Table 310.15(B)(17)
- Column 5 indicates the Amp rating of AC input breaker. EVO-1212F/EVO-1224F have built-in 20A breaker (15, Fig 2.1). **External 20A AC input breaker is required to be installed for EVO-1212F-HW/1224F-HW.** The Amp rating of this breaker is based on the following considerations:
 - The Amp rating of the fuse has to be \leq the Ampacity of wire size at Column 4. 20A rating has been selected based on Column 2.
 - Closest Standard Ampere Rating of Breaker (20A) has been used - Refer to NEC-2014 (National Electrical Code) - Section 240.6(A) regarding over current protection
 - Type of external AC input breaker (for EVO-1212F-HW / 1224F-HW) : Standard circuit breaker for 120 VAC Load Center/Breaker Panel/Panel Board

SECTION 3 | Installation

3.9 SIZING OF AC OUTPUT WIRING AND BREAKERS

3.9.1 EVO-1212F and EVO-1224F

120 VAC output is supplied through NEMA5-15 Duplex GFCI Outlets (15, Fig 2.1). The outlets are protected against over current through 15A Circuit Breaker (14, Fig 2.1).

Use power cord with NEMA5-15 plug and conductor size AWG #14.

3.9.2 EVO-1212F-HW and EVO-1224F-HW



WARNING!

For EVO-1212F-HW and EVO-1224F-HW, AC Breakers for the AC output circuits have NOT been provided internally. These have to be provided externally by the installer / user based on guidelines given below. Please note that guidelines given below on wire sizing and over-current protection will be superseded by the applicable National / Local Electrical Codes.



MISE EN GARDE!

Pour EVO-1212F-HW and EVO-1224F-HW breakers AC pour les circuits d'entrée AC ont pas été fournis en interne. Ceux-ci doivent être fournies à l'extérieur par l'installateur / utilisateur sur la base des directives données ci-dessous. Se il vous plaît noter que les directives ci-dessous sur dimensionnement des câbles et protection contre les surintensités seront remplacées par les nationaux / codes électriques locaux applicables.

Table 3.3 provides details of wire and breaker sizing for the AC output side for EVO-1212F-HW and EVO-1224F-HW.

AC wiring and breaker sizes on the AC output side are required to be determined by the Rated Load Current when operating in Inverter Mode (Column 1).

TABLE 3.3 SIZING OF AC OUTPUT WIRING AND BREAKERS				
Model No. and Rated Output Power in Inverter Mode (Column 1)	Rated AC Output Current in Inverter Mode (See Note 2) (Column 2)	NEC Ampacity = 125% of Column 2 (See Note 3) (Column 3)	Conductor Size based on NEC Ampacity at Column 3 (See Note 4) (Column 4)	Size of Breaker (Column 5)
EVO-1212F-HW (1200VA)	10A	12.5A	AWG #14	15A
EVO-1224F-HW (1200VA)	10A	12.5A	AWG #14	15A

SECTION 3 | Installation

NOTES FOR TABLE 3.3 - AC OUTPUT WIRING AND BREAKERS

- 1) Column 1 indicates Model No and Output Power (VA)
- 2) Column 2 indicates the Rated AC Output Current in Inverter Mode
- 3) Column 3 indicates NEC Ampacity based on which the output-wiring conductor is sized. This NEC Ampacity is not less than 125% of the Rated Output Current in Inverter Mode (Column 2). - Refer to NEC-2014 (National Electrical Code) - Section 215.2(A)(1)(a) regarding Feeder Circuit Conductors. PLEASE NOTE that when the unit is operating in Inverter Mode, it is considered to be an AC source that is feeding power to the Load Center / Breaker Panel on the load side. Hence, the AC output circuit of the unit is considered to be a Feeder Circuit for purposes of NEC-2014.
- 4) Column 4 indicates conductor size for the output side wiring. The size is based on NEC-2014 (National Electrical Code) - Ampacity Table 310.15(B)(16) for Raceway. Conductor size is based on (i) NEC Ampacity (Column 3), (ii) conductor temperature of 75°C and (iii) ambient temperature of 30°C / 86°F.
- 5) Column 5 indicates the Amp rating of breaker. Following should be considered:
 - a) Ampere rating should not be less than NEC Ampacity (Column 3) - Refer to NEC-2014 (National Electrical Code) - Section 215.3 regarding over-current protection of Feeder Circuit Conductors
 - b) Closest Standard Breaker Ampere Rating of 15A has been used - Refer to NEC-2014 (National Electrical Code) - Section 240.6(A) regarding Standard Ampere Ratings
 - c) As Standard Breaker Rating does not match the required NEC Ampacity at Column 3 (12.5A), the next higher Standard Ampere Rating of the breaker (15A) has been used
 - Refer to NEC-2014 (National Electrical Code) - Section 240.4(B) regarding over current devices rated 800 Amps or less
 - d) Type of breaker: Standard circuit breaker for 120 VAC Load Center /Breaker Panel
 - e) EVO-1212F and EVO-1224F use built-in Breaker (14, Fig 2.1). External 15A Breaker is required to be used for EVO-1212F-HW / 1224F-HW.

3.10 GFCI PROTECTION FOR VEHICLE APPLICATION

When EVO-1212F-HW and EVO-1224-HW are installed in vehicles, ensure that Ground Fault Circuit Interrupter(s) are installed in the vehicle wiring system to protect all branch circuits. Details of tested and approved GFCI's are given in Table 1.5.

EVO-1212F and EVO-1224F have built-in GFCI outlet.

3.11 GROUNDING TO EARTH OR TO OTHER DESIGNATED GROUND



Please read following on-line White Papers for complete understanding of Grounding at www.samlexamerica.com (Home > Support > White Papers):

- "Grounded Electrical Power Distribution"
- "Grounding System and Lightning / Ground Fault Protection"

SECTION 3 | Installation

Grounding means connecting (bonding) to Earth Ground or to the other designated Ground. For example, in a motorhome / caravan, the metal frame of the motorhome / caravan is normally designated as the Negative DC Ground / RV Ground. Similarly, all metal portions of boats and marine craft are bonded together and called Boat Ground.

Grounding is required for (i) protection against damage due to lightning strike and (ii) protection against electric shock due to "Ground Fault". In case of EVO™, "Ground Fault" may occur due to inadvertent contact between an energized ungrounded current carrying conductor and exposed metal surface resulting in voltage getting fed to (i) the metal chassis of the EVO™ or (ii) to the metal chassis of the devices connected to EVO™ or (iii) to the metal frame/ chassis in an RV / motorhome / caravan. When this energized exposed surface is touched, the voltage will drive current through the body to Earth Ground producing electric shock. When properly grounded to Earth Ground (or Frame / Chassis Ground in motorhome or caravan), the Leakage Current Protection Device (like RCD, GFCI etc.) or Over Current Protection Device (like Circuit Breaker or Fuse) will trip and interrupt the circuit feeding power from the AC source (EVO™ / AC Input) or the DC source (12V / 24V battery). Proper grounding will ensure that all exposed metal surfaces will have equal potential and will be bonded to (i) a single common Earth Ground point i.e. the Ground Rod / buried metallic water / gas pipe at the premises or (ii) the Frame / Chassis Ground in a motorhome / caravan.

3.12 GROUNDING ARRANGEMENT

Internally, EVO™ consists of DC and AC Section that are isolated through a transformer (See these sections in Figs 3.12 and 3.13). Both these sections are required to be grounded appropriately.

For wiring details for appropriate grounding, refer to Figs 3.12 and 3.13, and associated explanation under Section 3.13 and 3.14.

When using a generator instead of Grid, please ensure that the Neutral of the generator is bonded to the metal frame of the generator and the metal frame of the generator is bonded to Earth Ground through the Grounding Electrode (GE) i.e. the Ground Rod. Refer to Section 3.14.1 for additional details.

3.13 DC SIDE GROUNDING

Please refer to Figs 3.12 and 3.13.

DC side grounding involves bonding of the metal frame/chassis of EVO™, the metal chassis of the DC Electrical Panel and the Battery Negative Terminal to Earth Ground in shore based installation (Fig 3.12) or to the metal frame / "Chassis" of the motorhome / caravan (Fig 3.13). This ensures that in case of a ground fault in the +12V / +24V circuit, the fuse in the +Battery line blows to clear the fault. This fuse in the +Battery line has Ampere capacity matching the rated DC input current of the EVO™ in Inverter Mode. The wire size used for DC side grounding should be minimum AWG #6 or of the same size as the battery cable, whichever is thicker (Battery cable size should have minimum Ampacity \geq the Ampere rating of this battery fuse depending upon the model of the EVO™ being used). **This recommendation on sizing of the DC Side Grounding Wire will be superseded by the National / Local Electrical Codes.**

SECTION 3 | Installation



CAUTION!

As per American Boat and Yacht Council (ABYC) Standard E-11 for AC and DC Electrical Systems on Boats, the size of DC side grounding wire shall not be smaller than one size under that required for current carrying conductors supplying the device. Hence, for application on EVO™ on boat / yacht, the size of the DC side grounding conductor should be of the same or one size smaller than the size of battery cable specified in Table 3.1.



ATTENTION!

Selon le « American Boat and Yacht Council » (ABYC) la norme E-11 pour le système électrique CA et CC des bateaux, la taille du fil de mise à la terre du côté CC ne doit pas être inférieure à un format sous celle requise pour les conducteurs tenant le courant pour alimenter l'appareil. Par conséquent, pour l'application EVO™ sur le bateau / yacht, la taille du conducteur de mise à terre côté CC devrait être de la même ou strictement une taille plus petite que la taille du câble de batterie indiqué dans le tableau 3.1.



INFO

As described at Section 3.14, the metal frame / chassis of the EVO™ [Figs 3.12 and 3.13] is bonded to the Earth Ground "GE" (Ground Rod) for AC side grounding. It may be argued that if the metal frame / chassis of EVO™ is already bonded to Main Earth Ground "GE" for AC side grounding, why is it necessary to provide additional DC side grounding wiring? [Wiring that bonds DC Grounding Terminals "5", "G-B" and GE in Figs 3.12 and 3.13]. If separate thicker grounding wire of the same size as the battery cable was not provided for the DC side grounding and there was a ground fault in the battery circuit, very large DC fault current from Battery+ would flow through the smaller size AC grounding wires to the Battery Negative through Earth Ground. These smaller size AC side grounding wires would be damaged due to very high DC side fault current (100A to 200A depending on the Model of the EVO™ being used).

A DC Side Grounding Connector (5) (5 in Figs 2.1 and 3.8) is provided for connecting to the System Ground. The connector can accept wire sizes AWG # 4–6. The set screw size is M6.

A DC Distribution Panel, as shown in Figs 3.12 and 3.13, is normally provided to connect the batteries and distribute DC power to the inverter and to the other DC loads.

The Negative of the battery is connected to the Neg (-) Bus of the DC Electrical Panel which, in turn, is connected to its Grounding Bus Bar (G-B). Grounding Bus Bar G-B of the DC Electrical Panel is further bonded to the Grounding Bus Bar "G-B" of the Grid Electrical Panel and then to the Grounding Electrode (GE), also called Ground Rod. Hence, the Battery Negative, the chassis of the DC Electrical Panel and the metal chassis of the EVO™ will all be bonded to the Earth Ground.

SECTION 3 | Installation

Connect the DC Grounding Terminal (5) [5 in Figs 2.1 and 3.8], to the Grounding Bus Bar (G-B) in the DC Electrical Panel using AWG #6 insulated stranded copper wire. Similarly, use AWG #6 wire to connect the Grounding Bus Bar "G-B" in the DC Electrical Panel to the Grounding Bus Bar "G-B" in the Grid Electrical Panel. For application of EVO™ on a boat, the size of this wire should be of the same size or one size smaller than the battery Negative wire (See CAUTION! above).

The connections must be tight against bare metal. Use star washers to penetrate paint and corrosion. **As the Equipment Grounding Bus Bar ("G-B") in the DC Electrical Panel is bonded to the Grounding Electrode (GE) through Grounding Bus Bar "G-B" in the Grid Electrical Panel, the metal chassis of the EVO™ will be bonded to Earth Ground for protection against Ground fault on the DC side of EVO™.**

3.14 AC SIDE GROUNDING

3.14.1 AC Side Grounding Requirements for Generators

Small portable generators supplied with receptacles will often have the Neutral conductor bonded to the generator frame. The frame of portable generator is normally isolated from the Earth Ground.

Larger generators typically do not have the Neutral grounded to the frame. It is to be ensured that in these generators, the Neutral should be connected to the metal frame of the generator.



WARNING!

If a Generator is used to feed AC input, it is to be ensured that the Neutral of the Generator output is bonded to the metal frame of the Generator.



MISE EN GARDE!

Si un générateur est utilisé pour envoyer de l'entrée CA, c'est de s'assurer que la position neutre de la sortie du générateur est lié à la structure métallique du générateur.

3.14.2 AC Side Grounding of Typical Shore Based Installation

3.14.2.1 EVO-1212F and EVO-1224F: AC Side Grounding of Typical Shore Based Installation

Refer to the Installation Diagram for Typical Shore Based Installation for EVO-1212F and EVO-1224F at Fig 3.12.

a) AC Input Grounding: The metal chassis of EVO™ gets bonded to the Grounding Electrode (GE) / Ground Rod of the premises as follows:

- The metal chassis of EVO™ is connected to the Grounding Pin (G) of the AC Power Inlet Plug (9)
- The Grounding Pin (G) of the AC Power Inlet Plug (9) gets connected to the Grounding Bus Bar (G-B) in the Grid Electrical Panel through the grounding wire of AC input connection
- The Grounding Bus Bar (G-B) in the Grid Electrical Panel is bonded to Earth Ground through the Grounding Electrode (GE) / "Ground Rod" of the premises.

SECTION 3 | Installation

b) AC Output Grounding: The metal chassis of the AC load(s) get connected to the Grounding Electrode (GE) / Ground Rod of the premises as follows:

- The metal chassis of the AC load(s) is connected to the Grounding socket (G) of the GFCI outlet (10) in EVO™ through the Grounding Conductor of the load connection
- Grounding socket (G) of GFCI outlet “10” in EVO™ is connected to the metal chassis of EVO™.
- The metal chassis of EVO™ is connected to the Grounding Pin (G) of the AC Power Inlet Plug (9)
- The grounding Pin (G) of the AC Power Inlet (9) gets connected to the Grounding Bus Bar (G-B) in the Grid Electrical Panel through the grounding wire of AC input connection
- The Grounding Bus Bar (G-B) in the Grid Electrical Panel is bonded to Earth Ground through the Grounding Electrode (GE) / “Ground Rod” of the premises

3.14.2.2 EVO-1212F-HW and EVO-1224F-HW: AC Side Grounding of Typical Shore Based Installation

Refer to the Installation Diagram for Typical Shore Based Installation for EVO-1212F-HW and EVO-1224F-HW at Fig 3.13

a) AC Input Grounding: The metal chassis of EVO™ gets bonded to the Grounding Electrode (GE) / “Ground Rod” of the premises as follows:

- The metal chassis of EVO™ is connected to the “INPUT GND” Terminal (23) of the AC Input / Output Terminal Block (20) in EVO™
- The “INPUT GND” Terminal (23) of the AC Input / Output Terminal Block (20) in EVO™ gets connected to the Grounding Bus Bar (G-B) in the Grid Electrical Panel through the grounding wire of AC input connection
- The Grounding Bus Bar (G-B) in the Grid Electrical Panel is bonded to Earth Ground through the Grounding Electrode (GE) / “Ground Rod” of the premises

b) AC Output Grounding: The metal chassis of the AC load(s) gets connected to the Grounding Electrode (GE) / “Ground Rod” of the premises as follows:

- The metal chassis of the AC load(s) is connected to the Grounding Bus Bar (G-B) of the Electrical Sub Panel for EVO™ Output
- Grounding Bus Bar (G-B) of the Electrical Sub Panel for EVO™ Output is connected to metal chassis of EVO™ through the “OUTPUT GND” Terminal (26) of the AC Input / Output Terminal Block (20) in EVO™.
- The metal chassis of EVO™ is connected to the “INPUT GND” Terminal (23) of the AC Input / Output Terminal Block (20) in EVO™
- The “INPUT GND” Terminal (23) of the AC Input / Output Terminal Block (20) in EVO™ gets connected to the Grounding Bus Bar (G-B) in the Grid Electrical Panel through the grounding wire of AC input connection
- The Grounding Bus Bar (G-B) in the Grid Electrical Panel is bonded to Earth Ground through the Grounding Electrode (GE) / “Ground Rod” of the premises

3.14.3 AC Side Grounding of Typical RV / Mobile Installation

3.14.3.1 EVO-1212F and EVO-1224F: AC Side Grounding of Typical RV / Mobile Installation

Refer to the Installation Diagram for Typical RV / Mobile Installation for EVO-1212F and EVO-1224F at Fig 3.14.

SECTION 3 | Installation

- a) AC Input Grounding:** The metal chassis of EVO™ gets bonded to (i) the RV / Vehicle Chassis Ground when not connected to Grid Power and (ii) to the Grounding Electrode (GE) / Ground Rod of the Grid Power System of the premises when connected to Grid Power through the Grid Power Supply Cord as follows:
- The metal chassis of EVO™ is connected to the Grounding Pin (G) of the AC Power Inlet Plug (9)
 - The Grounding Pin (G) of the AC Power Inlet Plug (9) gets connected to the Grounding Bus Bar (G-B) in the Electrical Panel of the RV / vehicle through the grounding wire of AC input connection.
 - The Grounding Bus Bar (G-B) in the Electrical Panel of the RV / vehicle is bonded to the RV / Vehicle Chassis Ground. When the RV / vehicle is connected to the Grid through the Grid Power Inlet and Cord, the RV / Vehicle Chassis Ground gets bonded to the Earth Ground of the premises through the Grounding Electrode (GE) / "Ground Rod" of the premises of the Grid Power System supplying the RV / Vehicle .
- b) AC Output Grounding:** The metal chassis of AC load(s) gets bonded to (i) the RV / Vehicle Chassis Ground when not connected to Grid Power and (ii) to the Grounding Electrode (GE) / Ground Rod of the Grid Power System of the premises when connected to Grid Power through the Grid Power Supply Cord as follows:
- The metal chassis of the AC load(s) is connected to the Grounding socket (G) of the GFCI outlet (10) in EVO™ through the Grounding Conductor of the load connection
 - Grounding socket (G) of GFCI outlet "10" in EVO™ is connected to the metal chassis of EVO™.
 - The metal chassis of EVO™ is connected to the Grounding Pin (G) of the AC Power Inlet Plug (9)
 - The grounding Pin (G) of the AC Power Inlet (9) gets connected to the Grounding Bus Bar (G-B) in the Electrical Panel of the RV / vehicle through the grounding wire of AC input connection.
 - The Grounding Bus Bar (G-B) in the Electrical Panel of the RV / vehicle is bonded to the RV / Vehicle Chassis Ground. When the RV / vehicle is connected to the Grid through the Grid Power Inlet and Cord, the RV / Vehicle Chassis Ground gets bonded to the Earth Ground of the premises through the Grounding Electrode (GE) / "Ground Rod" of the premises of the Grid Power System supplying the RV / Vehicle

3.14.3.2 EVO-1212F-HW and EVO-1224F-HW:

Refer to the Installation Diagram for Typical RV / Mobile Installation for EVO-1212F-HW and EVO-1224F-HW at Fig 3.15.

- a) AC Input Grounding:** The metal chassis of EVO™ gets bonded to (i) the RV / Vehicle Chassis Ground when not connected to Grid Power and (ii) to the Grounding Electrode (GE) / Ground Rod of the Grid Power System of the premises when connected to Grid Power through the Grid Power Supply Cord as follows:
- The metal chassis of EVO™ is connected to the "INPUT GND" Terminal (23) of the AC Input / Output Terminal Block (20) in EVO™
 - The "INPUT GND" Terminal (23) of the AC Input / Output Terminal Block (20) in EVO™ gets connected to the Grounding Bus Bar (G-B) in the Electrical Panel of the RV through the grounding wire of AC input connection
 - The Grounding Bus Bar (G-B) in the Electrical Panel of the RV / vehicle is bonded to the RV / Vehicle Chassis Ground. When the RV / vehicle is connected to the Grid through the Grid Power Inlet and Cord, the RV / Vehicle Chassis Ground gets bonded to the Earth Ground of the premises through the Grounding Electrode (GE) / "Ground Rod" of the premises of the Grid Power System supplying the RV / Vehicle
- b) AC Output Grounding:** The metal chassis of the AC load(s) gets bonded to (i) the RV / Vehicle Chassis Ground when not connected to Grid Power and (ii) to the Grounding Electrode (GE) / Ground Rod of the Grid Power System of the premises when connected to Grid Power through the Grid Power Supply Cord as follows:

SECTION 3 | Installation

- The metal chassis of the AC load(s) is connected to the Grounding Bus Bar (G-B) of the Electrical Sub Panel for EVO™ Output
- Grounding Bus Bar (G-B) of the Electrical Sub Panel for EVO™ Output is connected to metal chassis of EVO™ through the “OUTPUT GND” Terminal (25) of the AC Input / Output Terminal Block (20) in EVO™.
- The metal chassis of EVO™ is connected to the “GRID GND” Terminal (22) of the AC Input / Output Terminal Block (20) in EVO™
- The “INPUT GND” Terminal (23) of the AC Input / Output Terminal Block (20) in EVO™ gets connected to the Grounding Bus Bar (G-B) in the Electrical Panel of the RV / vehicle through the grounding wire of AC input connection
- The Grounding Bus Bar (G-B) in the Electrical Panel of the RV / vehicle is bonded to the RV / Vehicle Chassis Ground. When the RV / vehicle is connected to the Grid through the Grid Power Inlet and Cord, the RV / Vehicle Chassis Ground gets bonded to the Earth Ground of the premises through the Grounding Electrode (GE) / “Ground Rod” of the premises of the Grid Power System supplying the RV / Vehicle
- **Thus, in keeping with the NEC requirements, the AC Grounds of EVO™ and the Grid Electrical Panel will be bonded to the Earth Ground only at one single point at the Grid Electrical Panel feeding the EVO™.**

3.14.4 Switching Of Bonding Of Output Neutral To Chassis Ground

As required by NEC and UL Standard 458, automatic switching of bonding between the Output Neutral and Chassis Ground has been provided in EVO™ through “Output Neutral and Chassis Ground Bond Switching Relay” (RY2 in Fig 4.1). Switching is carried as follows:

- When operating as an inverter, the current carrying conductor of the Inverter Section that is connected to the Output Neutral terminal of the EVO™ is bonded to the metal chassis of EVO™ by the “Output Neutral to Chassis Ground Bond Switching Relay” (RY2 in Fig 4.1). As the metal chassis of EVO™ is in turn bonded to the Earth Ground (in shore installations) or RV Ground (chassis of the RV) or to the Boat Ground (DC Negative Grounding Bus Bar and the Main AC Grounding Bus Bar are tied together in a boat and this is called the “Boat Ground”), this current carrying conductor of the Inverter Section (connected to the Output Neutral Terminal) will become the Grounded Conductor (GC) or the Neutral of the Inverter Section.
- When in Charging Mode, the Neutral conductor of the Grid power will be connected to the Output Neutral terminal of EVO™. At the same time, the “Output Neutral to Chassis Ground Bond Switching Relay” (RY2 in Fig 4.1) will unbond (disconnect) the Output Neutral connector of EVO™ from the metal chassis of EVO™. This will ensure that the Grounded Conductor (GC) i.e. the Neutral of the Grid power is bonded to the Earth Ground at one single point at the location of the AC Power Distribution System of the Marina / RV Park / Shore Power.
- **Disabling Neutral to Ground Bond:** In some applications, the Output Neutral of EVO™ may be required to remain isolated from the chassis/Ground at all times. For this, automatic Output Neutral to Chassis Ground bond can be disabled by disconnecting the Insulated Male/Female Quick Disconnect located in the AC wiring compartment. [Please see (i) 27, Fig 3.9.2(a) and (ii) “27” in Figs 4.1].

Please read the following on-line White Papers for more details at www.samlexamerica.com (Home > Support > White Papers):

- **“Neutral to Ground Switching in RV and Marine Applications**

SECTION 3 | Installation

3.15 BATTERY TEMPERATURE SENSOR FOR LEAD ACID BATTERIES

Lead Acid Battery charging voltages are required to be compensated based on the temperature of the battery cells. Hence, Battery Temperature Sensor Model EVO-BCTS has been provided. Please see constructional and fitment details at [Fig 2.5(a)] and [Fig 2.5(b)] respectively.

The sensor head contains a Negative Temperature Coefficient (NTC) Resistor with 2 output wires: "NTC+" is connected to Pin 4 of the RJ-45 Plug and "NTC -" is connected to Pin 5 of the RJ-45 Plug. The RJ-45 Plug is required to be connected to the RJ-45 Jack (6, Fig 2.1). The Temperature Sensor is used to ensure optimum charging of Lead Acid Batteries by modifying the charging voltages based on the battery temperature. In addition to compensating Absorption, Float and Equalization voltages, the voltage thresholds of parameters "LOW VOLTAGE ALARM", "BATTERY LOW VOLTAGE", "RESET VOLTAGE", "BATTERY OVER VOLTAGE" and "RESET TO BULK" are also temperature compensated. Temperature compensation will be carried out over temperature range of -20°C to +60°C. Table 6.2 shows the programmable range. Default setting for the Temperature Coefficient of Voltage is -4mV/°C/Cell.

3.16 INSTALLING CONTROL INPUT WIRING FROM LITHIUM BATTERY MANAGEMENT SYSTEM (BMS) TO ENABLE/ DISABLE CHARGING OR INVERTING

The Battery Charger Section is designed to charge Lead Acid, Nickel-Zinc (Ni-Zn) or Lithium Ion Batteries.

Lead Acid Battery charging voltages are required to be compensated based on the temperature of the battery cells. Hence, Battery Temperature Sensor is required to be connected to the RJ-45 Jack (6, Fig 2.1) as explained at Section 3.15.

Charging voltages of Lithium Battery are not affected by temperature and hence, Battery Temperature Sensor is not required to be used.

For charging Lithium Ion Battery, programming parameter "BATTERY TYPE" has to be changed from **Setting 0=Lead Acid** (Default setting) to **Setting 1=Lithium**. This programming change is carried out using optional Remote Control EVO-RC-Plus. *Please refer to the following Sections of EVO-RC-PLUS Manual:*

- *Screen 22 in Fig 4.2 and Table 4.3*
- *Section 4.4.2.22.1*

Pins 4 and 5 of the RJ-45 Jack marked "Battery Temp. Sensor" (6 and 19, Fig 2.1) are required to be connected to the Normally Open Contacts of relay in the Battery Management System (BMS) of the Lithium Battery for "Stop Charging or "Stop Inverting" signals. *[See details at Section 4.4.2.22.2 of EVO-RC-PLUS Remote Control Manual]*. The BMS will close the Relay contacts as follows:

- To "Stop Charging": Due to (i) overvoltage of individual cell / overall battery pack, or (ii) over temperature of individual cell or overall battery pack
- To "Stop Inverting": Due to deep discharge to the level of Low Battery Cut Off Voltage

When the Relay contacts in the BMS close, Pins 4 and 5 of RJ-45 Jack will be shorted. The following actions will be activated:

SECTION 3 | Installation

- EVO in Charging Mode:** The charging will stop (charging current will be reduced to 0A). The 2nd Line of the Charging Mode Screens shown in the Menu Map for Charging Mode Screens (Fig 3.7 in EVO-RC Plus Manual) will show "Charger Off by BMS" as shown in example below for Screen No. 1

Screen No.1

```

EVO-1212F    Charging
Charger Off by BMS
Battery 12.00V 0.0A
External      0.0A
    
```

- EVO in Inverting Mode:** Inverting will stop. EVO™ will go to Standby Mode. The right half of the 1st Line of the Standby Mode Screens shown in the Menu Map for Standby Mode Screens (Fig 3.8 in EVO-RC Plus Manual) will show "Inv stop by BMS" in 2 consecutive displays - first "Inv stop" and then "by BMS" as shown in example below:

Screen No.1

For 2 sec

```

EVO-1212F    [Inv stop]
AC Output :   0.00V
              <0.10A
              00.00Hz
    
```

Screen No.1

For 2 sec

```

EVO-1212F    [by BMS]
AC Output :   0.00V
              <0.10A
              00.00Hz
    
```

SECTION 3 | Installation

3.17 SHORE BASED INSTALLATION

3.17.1 Typical Shore Based Installation

Fig. 3.12 illustrates a typical shore based installation for EVO-1212F / EVO-1224F. Fig 3.13 illustrates typical shore based installation for EVO-1212F-HW / EVO-1224-HW.

- Battery is connected to the DC input connections through DC Electrical Panel with an appropriate fuse to protect the DC input cables against short circuit
- Battery Charger Temperature Sensor Model EVO-BCTS is installed on the Positive or Negative post of the battery and connected to the RJ-45 Jack for the Temperature Sensor
- Supplementary battery charging is being carried out through a solar array and a Charge Controller connected to the DC input provided for external charge controller.
- AC input to the EVO™ is fed from the Grid. Alternatively, AC input may be fed from a generator.
- AC output from the EVO™ is fed to the AC Electrical Sub-Panel for EVO™



WARNING!

In case generator is used to feed AC input to the EVO, the following should be ensured:

- Ensure that the Neutral of the generator is bonded to the chassis of the generator. Please see Section 3.14.1 for details.
- If the Generator is a 120VAC / 240VAC Split Single Phase with 120 VAC phase fed to the EVO™, then both 120 VAC Split Phases of the generator should be equally loaded (balanced) to prevent deterioration of regulation of generator's output voltage / frequency. Poor regulation of generator output voltage / frequency may lead to interruption of charging / AC pass through in the EVO™ (EVO will transfer to Inverting Mode).



MISE EN GARDE!

En cas générateur est utilisé pour l'alimentation d'entrée AC à l'EVO, les dispositions suivantes devraient être prises :

- *S'assurer que le neutre du générateur est fixé sur le châssis du générateur. Veuillez voir la section 3.14.1 pour plus de détails.*
- *Si le générateur est un 120 VAC / 240 VAC monophasé avec Split 120VCA alimenté phase à l'EVO, puis les deux phases de 120 V C.A. Split le générateur devrait être tout aussi chargé (équilibré) afin de prévenir la détérioration du règlement de générateur's fréquence/tension de sortie. Une mauvaise régulation de tension / fréquence de sortie du générateur peut conduire à l'interruption de la charge / AC passer à travers dans l'EVO™ (EVO va transférer à l'inversion de mode).*

SECTION 3 | Installation

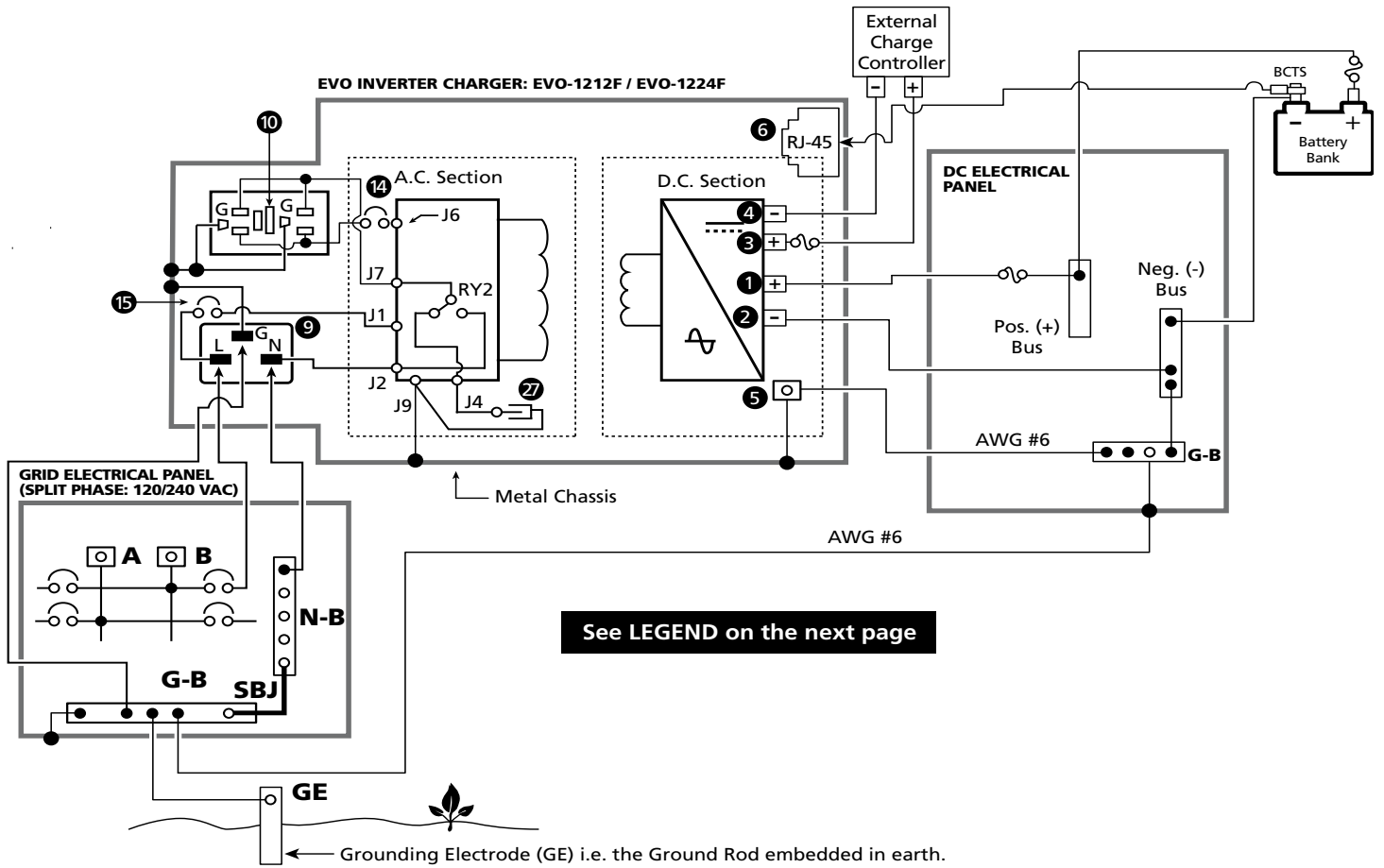

Fig 3.12 Installation Diagram for Typical Shore Based Installation for EVO-1212F and EVO-1224F





SECTION 3 | Installation

LEGEND FOR FIG 3.12

NOTE:

For sizing of wiring and fuses, refer to the following:

- a) DC side wiring: Table 3.1
- b) AC side wiring: Table 3.2 for AC input and Table 3.3 for AC output

- L. Line Terminal
- L-B. Line Bus Bar
- N. Neutral Terminal
- N-G. Neutral to Ground Bond
- N-B. Neutral Bus Bar
- G-B. Grounding Bus Bar
- SBJ. System Bonding Jumper
- J1, 2, 4, 7, 9 Male Tab Terminals on internal Circuit Board
- RY2. Relay for Neutral to Ground Bond Switching (Section 4.4.2)
- BCTS. Battery Charger Temperature Sensor EVO-BCTS [Fig 2.5(a)]
 1. Battery Positive Input Connector (1, Figs 2.1 / 3.8)
 2. Battery Negative Input Connector (2, Figs 2.1 / 3.8)
 3. Positive Input Connector for External Charge Controller (3, Figs 2.1 / 3.8)
 4. Negative Input Connector for External Charge Controller (4, Figs 2.1 / 3.8)
 5. DC Side Grounding Terminal on EVO™ (5, Fig 2.1)
 6. RJ-45 Jack for Temperature Sensor (6, Fig 2.1)
- GE. Grounding Electrode. Also called "Ground Rod"
- 9. 20A Inlet Plug Connector IEC 60320 C20 (9, Fig 2.1)
- 10. NEMA5-15 Duplex GFCI Outlets (10, Fig 2.1)
- 14. 15A Built-in Breaker for AC output (14, Fig 2.1)
- 15. 20A Built-in Breaker for AC input (15, Fig 2.1)
- 27. Quick Disconnect to disconnect Neutral to Ground bond (27, Fig 3.9.2)
-  Circuit breaker
-  Fuse
- A**  120 VAC Leg, Phase A
- B**  120 VAC Leg, Phase B (180° out of phase with Phase A Leg)



WARNING!

In case a Generator is used to feed AC input, please ensure that the Neutral conductor of the Generator is bonded to the chassis / frame of the Generator. Please refer to Section 3.14.1 for details.



MISE EN GARDE!

En cas d'un générateur est utilisé pour envoyer de l'entrée CA, veuillez vous assurer que le conducteur neutre de la génératrice est collé sur le châssis / cadre de la génératrice. Veuillez vous reporter à la section 3.14.1 pour plus de détails.

SECTION 3 | Installation

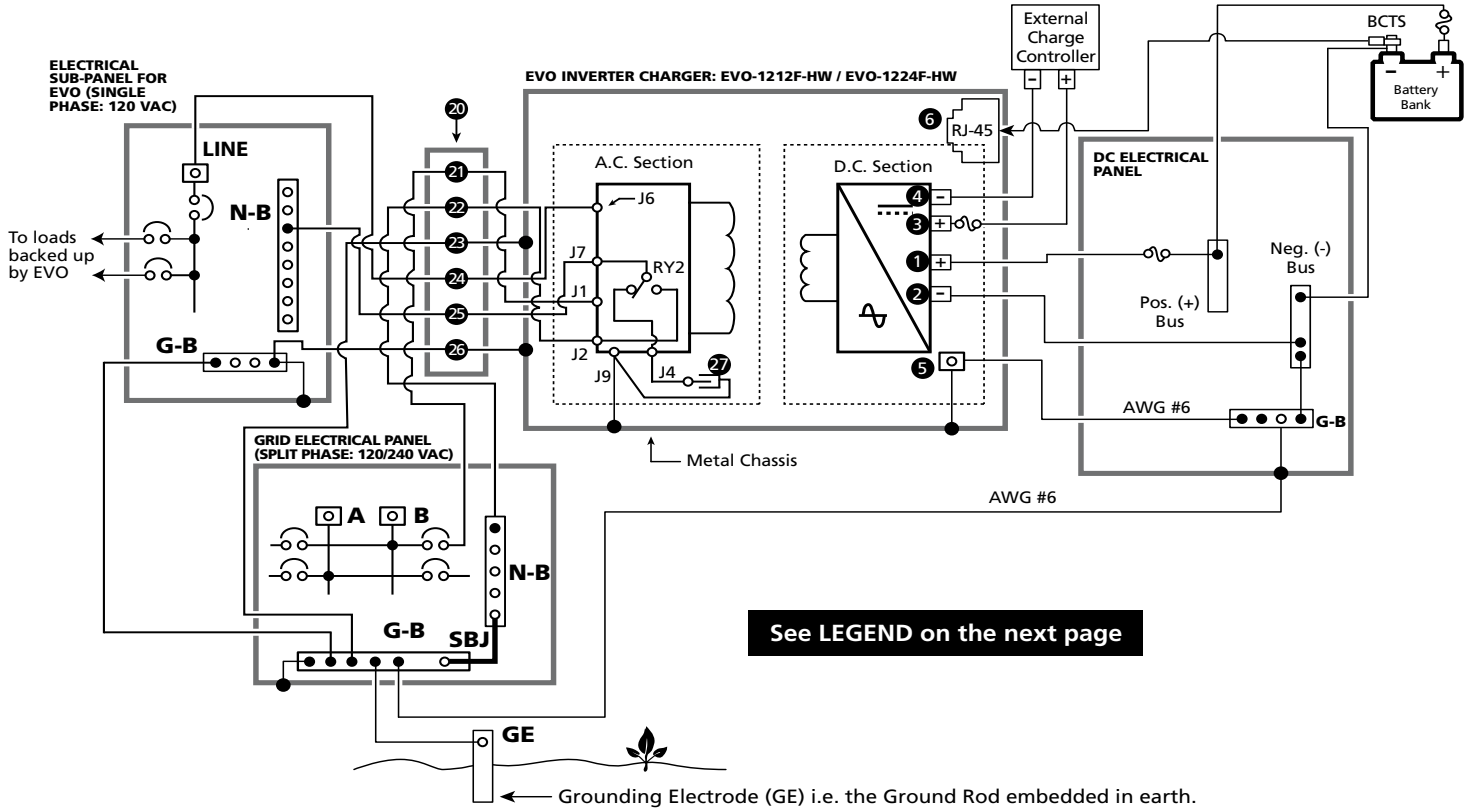

Fig 3.13 Installation Diagram for Typical Shore Based Installation for EVO-1212F-HW and EVO-1224F-HW





SECTION 3 | Installation

LEGEND FOR FIG 3.13

NOTE:

For sizing of wiring and fuses, refer to the following:

- a) DC side wiring: Table 3.1
- b) AC side wiring: Table 3.2 for AC input and Table 3.3 for AC output

- L. Line Terminal
- L-B. Line Bus Bar
- N. Neutral Terminal
- N-G. Neutral to Ground Bond
- N-B. Neutral Bus Bar
- G-B. Grounding Bus Bar
- SBJ. System Bounding Jumper
- J1, 2, 4, 7, 9 Male Tab Terminals on internal Circuit Board
- RY2. Relay for Neutral to Ground Bond Switching (Section 4.4.2)
- BCTS. Battery Charger Temperature Sensor EVO-BCTS [Fig 2.5(a)]
 1. Battery Positive Input Connector (1, Figs 2.1 / 3.8)
 2. Battery Negative Input Connector (2, Figs 2.1 / 3.8)
 3. Positive Input Connector for External Charge Controller (3, Figs 2.1 / 3.8)
 4. Negative Input Connector for External Charge Controller (4, Figs 2.1 / 3.8)
 5. DC Side Grounding Terminal on EVO™ (5, Fig 2.1)
 6. RJ-45 Jack for Temperature Sensor (6, Fig 2.1)
- GE. Grounding Electrode. Also called "Ground Rod"
- 20. AC Input / Output Terminal Block
- 21. INPUT L
- 22. INPUT N
- 23. INPUT GND
- 24. OUTPUT L
- 25. OUTPUT N
- 26. OUTPUT GND
- 27. Quick Disconnect to disconnect Neutral to Ground bond
-  Circuit breaker
-  Fuse
- A**  120 VAC Leg, Phase A
- B**  120 VAC Leg, Phase B (180° out of phase with Phase A Leg)

Refer to AC Input / Output Connections for EVO-1212F-HW / 1224F-HW at Fig 3.9.2(a)



WARNING!

In case a Generator is used to feed AC input, please ensure that the Neutral conductor of the Generator is bonded to the chassis / frame of the Generator. Please refer to Section 3.14.2 for details.



MISE EN GARDE!

En cas d'un générateur est utilisé pour envoyer de l'entrée CA, veuillez vous assurer que le conducteur neutre de la génératrice est collé sur le châssis / cadre de la génératrice. Veuillez vous reporter à la section 3.14.2 pour plus de détails.

SECTION 3 | Installation

3.18 MOBILE INSTALLATION - GENERAL INFORMATION

3.18.1 GFCI Protection for Vehicle Application

When EVO-1212F-HW / EVO-1224F-HW is installed in vehicles, it is to be ensured that Ground Fault Circuit Interrupter(s) [GFCI] are installed in the vehicle wiring system to protect all branch circuits. EVO-1212F and EVO-1224F come with Duplex GFCI, NEMA5-15 outlet.



WARNING!

Please ensure that when using hard-wired versions EVO-1212F-HW, Ground Fault Circuit Interrupter(s) [GFCI] are installed in the vehicle wiring system to protect all branch circuits. GFCIs listed in Table 1.5 have been tested to operate satisfactorily and are acceptable.



MISE EN GARDE!

Veillez vous assurer que lors de l'utilisation de versions câblées EVO-1212F-HW, Disjoncteur(s) [FUIITE] sont installés dans le système de câblage du véhicule pour protéger tous les circuits de dérivation. Des disjoncteurs de terre ci-dessous ont été testé. Leur fonctionnement est acceptable, Table 1.5.

3.18.2 Requirement of Deep Cycle, Auxiliary Battery and Battery Isolator for Powering Inverters in Mobile Installations

Basic information on Lead Acid Batteries is given in Section 1.4 under "General Information - Lead Acid batteries". For details, read on-line White Paper titled "Batteries, Chargers & Alternator" at: www.samlexamerica.com (Home > Support > White Papers).

An RV / vehicle has Starter, Lighting and Ignition (SLI) battery. As explained in White Paper titled "Batteries, Chargers and Alternators", SLI batteries are designed to produce high power in short bursts for cranking.

SLI batteries use lots of thin plates to maximize the surface area of the plates for providing very large bursts of current (also specified as Cranking Amps). This allows very high starting current but causes the plates to warp when the battery is cycled. Vehicle starting typically discharges 1%–3% of a healthy SLI battery's capacity. The automotive SLI battery is not designed for repeated deep discharge where up to 80% of the battery capacity is discharged and then recharged. If an SLI battery is used for this type of deep discharge application, its useful service life will be drastically reduced. Hence, this type of battery is not recommended for the storage of energy for inverter applications. A second deep cycle auxiliary battery must be installed in the RV for powering the EVO™ (Deep cycle, auxiliary battery is shown in Figs 3.14 and 3.15).

When the second auxiliary deep cycle battery is used, a Battery Isolator is required that will allow parallel connection of the two batteries for charging when the alternator is ON and disconnecting the parallel connection when the alternator is stopped (Isolator is shown in Figs 3.14 and 3.15). The capacity of the Battery Isolator should be as follows:

SECTION 3 | Installation

- **For EVO-1212F / EVO-1212F-HW:** The maximum continuous DC current required is 152A. The capacity of the Battery Isolator should be more than 152A or more than the capacity of the alternator, whichever is higher.
- **For EVO-1224F / EVO-1224-HW:** The maximum continuous DC current required is 76A. The capacity of the Battery Isolator should be more than 76A or more than the capacity of the alternator, whichever is higher.

3.18.3 Requirement to Keep the Neutral Conductor of Shore Power Isolated From the Chassis Ground of the RV

As explained in on-line White Paper titled “Grounded Electrical Power Distribution System” at www.samlexamerica.com (Home > Support > White Papers), in the RV, the Neutral Bus Bar is NOT bonded to the Chassis of the RV. In the RV, the Neutral is floating with respect to the chassis of the RV. This is necessary for safety because if the Neutral was bonded to the chassis of the RV and if the Neutral and the Hot got reversed by mistake, the chassis of the RV will be at 120 VAC with respect to the Earth Ground. If a person standing on the Earth Ground touches the chassis of the RV, he will be fed with 120 VAC and will receive electrical shock!

3.18.4 Typical Mobile Installation

Fig 3.14 illustrates typical RV installation for EVO-1212F / EVO-1224F using 30A, 120VAC, Single Phase Service Inlet. Fig 3.15 illustrates typical RV installation for hard-wired versions EVO-1212F / EVO-1224-HW using 30A, 120VAC Single Phase Service Inlet:

- Auxiliary Battery is connected to the DC input connections through an appropriate fuse to protect the DC input cables against short circuit
- When AC input from the Grid is not available, the Auxiliary battery will be charged by the alternator through the Battery Isolator
- Battery Charger Temperature Sensor Model BCTS-EVO is installed on the Positive or Negative post of the auxiliary battery and connected to the RJ-45 Jack for the Temperature Sensor
- Supplementary battery charging is being carried out through a solar array and a Charge Controller connected to the DC input provided for external battery charger
- AC input to the EVO™ is fed from the Electrical Panel of the RV (through suitable breaker).
- If the RV has a 50A Service, 120VAC Single Phase input to the EVO™ can be fed from either of the 2 Split Phase Legs of the 50A RV Panel (through suitable breaker).
- AC output from the EVO™ is fed to the Electrical Sub-Panel for EVO™ (Use 120V version and NOT 120/240 Split Phase version of the Electrical Sub-panel)

SECTION 3 | Installation

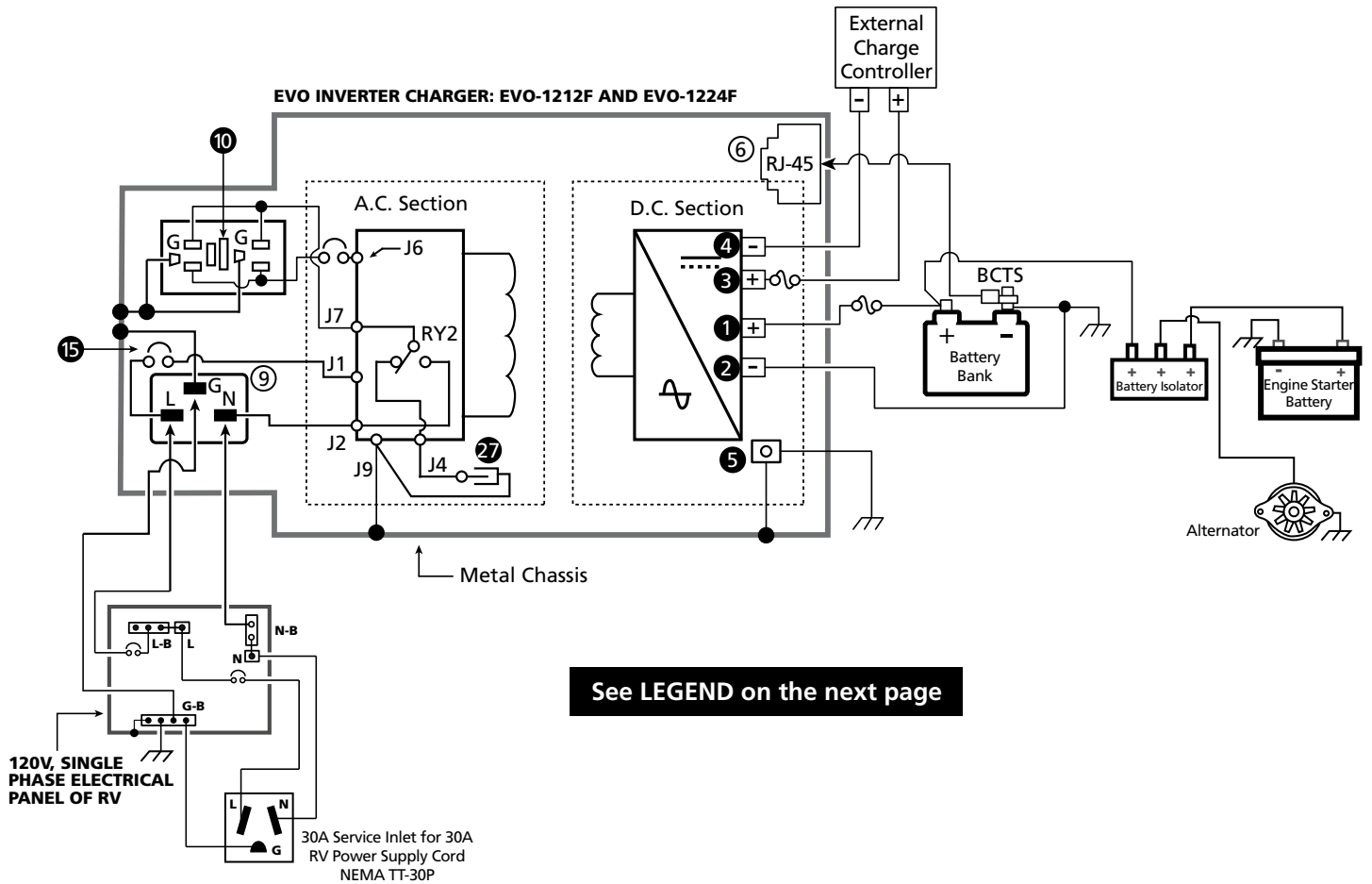





Fig 3.14 Installation Diagram for Typical RV / Mobile Installation for EVO-1212F and EVO-1224F

SECTION 3 | Installation

LEGEND FOR FIG 3.14

NOTE:

For sizing of wiring and fuses, refer to the following:

- a) DC side wiring: Table 3.1
 - b) AC side wiring: Table 3.2
- L. Line Terminal
L-B. Line Bus Bar
N. Neutral Terminal
N-G. Neutral to Ground Bond
N-B. Neutral Bus Bar
G-B. Grounding Bus Bar
SBJ. System Bounding Jumper
J1, 2, 4, 7, 9 Male Tab Terminals on internal Circuit Board
RY2. Relay for Neutral to Ground Bond Switching (Section 4.4.2)
BCTS. Battery Charger Temperature Sensor EVO-BCTS [Fig 2.5(a)]
1. Battery Positive Input Connector (1, Figs 2.1 / 3.8)
2. Battery Negative Input Connector (2, Figs 2.1 / 3.8)
3. Positive Input Connector for External Charge Controller (3, Figs 2.1 / 3.8)
4. Negative Input Connector for External Charge Controller (4, Figs 2.1 / 3.8)
5. DC Side Grounding Terminal on EVO™ (5, Figs 2.1/ 3.8)
6. RJ-45 Jack for Temperature Sensor (6, Fig 2.1)
GE. Grounding Electrode. Also called "Ground Rod"
9. 20A Inlet Plug Connector IEC 60320 C20 (9, Fig 2.1)
10. NEMA5-15 Duplex GFCI Outlets (10, Fig 2.1)
14. 15A Built-in Breaker for AC output (14, Fig 2.1)
15. 20A Built-in Breaker for AC input (15, Fig 2.1)
27. "Quick Disconnect" to disconnect Neutral to Ground bond (27, Fig 3.9.2)
 Circuit breaker
 Fuse
A  120 VAC Leg, Phase A
B  120 VAC Leg, Phase B (180° out of phase with Phase A Leg)



WARNING!

In case a Generator is used to feed AC input, please ensure that the Neutral conductor of the Generator is bonded to the chassis / frame of the Generator. Please refer to Section 3.14.1 for details.



MISE EN GARDE!

In cas d'un générateur est utilisé pour envoyer de l'entrée CA, veuillez vous assurer que le conducteur neutre de la génératrice est collé sur le châssis / cadre de la génératrice. Veuillez vous reporter à la section 3.14.1 pour plus de détails.

SECTION 3 | Installation

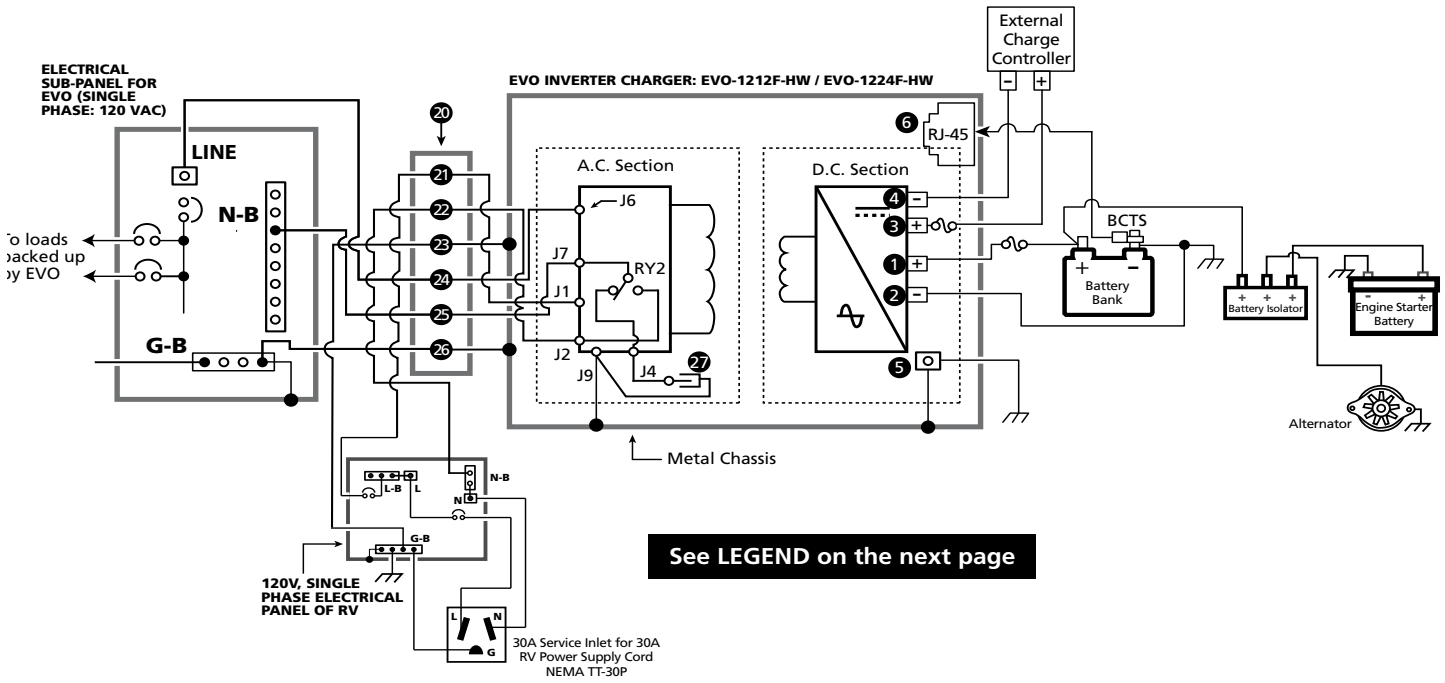

Fig 3.15 Installation Diagram for Typical RV / Mobile Installation for EVO-1212F-HW and EVO-1224F-HW





SECTION 3 | Installation

LEGEND FOR FIG 3.15

NOTE:

For sizing of wiring and fuses, refer to the following:

- a) DC side wiring: Table 3.1
- b) AC side wiring: Table 3.2 for AC input and Table 4.3 for AC output

- L. Line Terminal
- L-B. Line Bus Bar
- N. Neutral Terminal
- N-G. Neutral to Ground Bond
- N-B. Neutral Bus Bar
- G-B. Grounding Bus Bar
- SBJ. System Bounding Jumper
- J1, 2, 4, 7, 9 Male Tab Terminals on internal Circuit Board
- RY2. Relay for Neutral to Ground Bond Switching (Section 4.4.2)
- BCTS. Battery Charger Temperature Sensor EVO-BCTS [Fig 2.5(a)]
 1. Battery Positive Input Connector (1, Figs 2.1 / 3.8)
 2. Battery Negative Input Connector (2, Figs 2.1 / 3.8)
 3. Positive Input Connector for External Charge Controller (3, Figs 2.1 / 3.8)
 4. Negative Input Connector for External Charge Controller (4, Figs 2.1 / 3.8)
 5. DC Side Grounding Terminal on EVO™ (5, Figs 2.1 / 3.8)
 6. RJ-45 Jack for Temperature Sensor (6, Fig 2.1)
- GE. Grounding Electrode. Also called "Ground Rod"
- 20. AC Input / Output Terminal Block
 21. INPUT L
 22. INPUT N
 23. INPUT GND
 24. OUTPUT L
 25. OUTPUT N
 26. OUTPUT GND
 27. Quick Disconnect to disconnect Neutral to Ground bond
-  Circuit breaker
-  Fuse
- A**  120 VAC Leg, Phase A
- B**  120 VAC Leg, Phase B (180° out of phase with Phase A Leg)

Refer to AC Input / Output
Connections for EVO-1212F-HW
/ 1224F-HW at Fig 3.9.2(a)



WARNING!

In case a Generator is used to feed AC input, please ensure that the Neutral conductor of the Generator is bonded to the chassis / frame of the Generator. Please refer to Section 3.14.2 for details.



MISE EN GARDE!

En cas d'un générateur est utilisé pour envoyer de l'entrée CA, veuillez vous assurer que le conducteur neutre de la génératrice est collé sur le châssis / cadre de la génératrice. Veuillez vous reporter à la section 3.14.2 pour plus de détails.

SECTION 4 | General Description & Principles of Operation

4.1 GENERAL DESCRIPTION

EVO Series is a Low Frequency Type, Pure Sine Wave, Single Phase Inverter-Charger with a built-in Transfer Relay. It uses high performance, 100MHz SP (Digital Signal Processing) type of micro-controller and Pulse Width Modulation (PWM) control. It is Bi-Directional i.e. it uses a common Converter Section consisting of Low Frequency Isolation Transformer and Mosfet based H-Bridge that can work in two directions as follows:

- 1) AC to DC Charging Mode: The common Converter Section is used to convert external AC input power to DC output power to charge the batteries and at the same time, pass through the AC input power to the AC loads
- 2) DC to AC Inverting Mode: The common Converter Section is used to convert DC input power from the batteries to AC output power to feed the AC loads

The above Bi-Directional implementation allows the same power components to be used in both directions resulting in high- energy transfer efficiency with fewer components and higher reliability



INFO

Please note that as the unit is Bi-Directional with a common Converter Section as explained above, it cannot work as inverter and charger at the same time

4.2 COMPONENTS OF THE SYSTEM

It consists of 3 Sections – Inverter Section, Battery Charger Section and AC Input/Transfer Relay Section. The unit is fed with the following inputs:

- 120 VAC, 60 Hz, Single Phase AC input
- DC Battery Source consisting of 12V/24V battery bank. - 4 versions of EVO are available. 2 versions for 12 VDC battery input (EVO-2212F and EVO-1212F-HW) & 2 for 24 VDC battery input (EVO-1224F and EVO-1224F-HW)
- Additional external charging source: Solar Charge Controller of up to 50A capacity. The output of the external Solar Charge Controller is routed through this unit and operates in parallel with the internal charger. The current delivered by the external charge controller is measured in real time. The internal charging current is controlled to ensure that the combined current fed to the battery does not exceed the programmed value of parameter "BULK CURRENT". This improves the life of the battery. Please see Section 5.4 for more details.

4.3 INVERTER SECTION

The Inverter Section is a heavy-duty, continuous rated, DSP micro-controller based inverter generating a Pure Sine Wave output of 120 VAC, 60 Hz from the DC Battery Source. It is able to supply AC power to various types of AC loads such as resistive loads (heaters, incandescent lamps etc) or reactive loads (motors, air conditioners, refrigerators, vacuum cleaners, fans, pumps, Switched Mode Power Supplies (SMPS) used in audio / video equipment and computers, etc.).

4.3.1 Principle of working of Inverter Section

Low DC voltage from the DC Battery Source is inverted to AC voltage in two steps. Low DC voltage from the DC Battery Source is first converted to low frequency (60 Hz), low voltage synthesized sine wave AC using Mosfet

SECTION 4 | General Description & Principles of Operation

based H-bridge configuration and high frequency (30 KHz) PWM (Pulse Width Modulation) technique. The low frequency, low voltage synthesized sine wave is then stepped up to 120 VAC pure sine wave voltage using a low frequency Isolation Transformer and filtration circuit to remove 30 KHz PWM frequency component. This type of DC to AC inversion is called Hybrid Type – a combination of low and high frequency implementation. Distinctive features of the Inverter Section are given below:

Soft Start: The inverter design incorporates “Soft Start” feature with the following advantages and protections:

- When the unit powers up, it starts in Inverting Mode first. The output voltage ramps up gradually from around 48 VAC to 120 VAC in around 200 ms. This reduces otherwise very high starting inrush current drawn by AC loads like Switched Mode Power Supplies (SMPS) and motor driven loads like fans, pumps, compressors etc. This will result in lower motor inrush current (which typically can be up to 650% of the full load current of the motor), which means lesser mechanical stresses, wear and tear and increased lifetime of the motor, coupling and fan. Additionally, the impact on the load side components is greatly reduced, meaning less likelihood of causing problematic voltage drops during starting.

Power Surge – Up to 300%:

- The inverter is able to deliver very high surge power / current of up to 300% for 1 ms followed by 200% for 100 ms. This range of high instantaneous power is delivered at the rated voltage and hence, it is able to provide very high starting torque for difficult motor driven loads like compressors and pumps that require higher Locked Rotor Current during startup.
- If the power drawn by the load exceeds the above surge ratings, the inverter protects itself by limiting the load current to 300% / 200% which results in reduction of output voltage and consequent reduction in load current. The output voltage recovers automatically when power drawn by the load drops below the above surge limits

Power Boost up to 150%: Higher percentage of rated power can be provided for limited time periods as follows:

- 150% for 30 sec
- 140% for 1 min
- 120% for 10 min
- 110% for 30 min

4.4 TRANSFER RELAY SECTION

Transfer Relay Section is used to either feed AC input power from external AC input source (e.g. Grid/Generator) to the Battery Charger Section and at the same time, pass through the AC power from the external AC input power source to the load (As long as the external AC input power is available and is within the programmed limits of voltage and frequency) or to transfer the load to the Inverter Section (In case of loss of the external AC input power source or if this source is not within the programmed limits of voltage and frequency). Typical transfer time is 16 milliseconds from the AC input source to Inverter and <1ms from Inverter to the AC input source. Heavy duty 40A, Transfer Relay [RY1, Fig 4.1] is used for reliable transfer of power.

4.4.1 AC Transfer and Output Neutral To Chassis Ground Bond Switching

As required by NEC and UL Standard 458, automatic switching of bonding between the Output Neutral and Chassis Ground has been provided in EVO through “Output Neutral to Chassis Ground Bond Switching Relay” [RY.2 in Fig 4.1]. Switching of bonding is carried out as follows:

SECTION 4 | General Description & Principles of Operation

- (a) When operating as an inverter, the current carrying conductor of the Inverter Section that is connected to the Output Neutral terminal of EVO is bonded to the metal chassis of EVO by the “Output Neutral to Chassis Ground Bond Switching Relay” [RY.2 in Fig 4.1]. As the metal chassis of EVO is in turn bonded to the Earth Ground (in shore installations) or to the RV Ground (chassis of the RV) or to the Boat Ground (DC Negative Grounding Bus Bar and the Main AC Grounding Bus Bar are tied together in a boat and this is called the “Boat Ground”), this current carrying conductor of the Inverter Section (connected to the output terminal) will become the Grounded Conductor (GC) or the Neutral of the Inverter Section.
- (b) When in Charging Mode, the Neutral conductor of the AC input source will be connected to the Output Neutral terminal of EVO. At the same time, the “Output Neutral to Chassis Ground Bond Switching Relay” [RY.2 in Fig 4.1] will unbond (disconnect) the Output Neutral connector of EVO from the metal chassis of EVO. This will ensure that the Grounded Conductor (GC) i.e. the Neutral of the AC input power source is bonded to the Earth Ground at one single point at the location of the AC Power Distribution System of the Marina/RV Park/Shore Power.
- (c) **Disabling Neutral to Ground Bond:** In some applications, the Output Neutral of EVO may be required to remain isolated from the chassis/Ground at all times. For this, automatic Output Neutral to Ground bond can be disabled by disconnecting the Male/Female Quick Disconnect located in the AC wiring compartment. [Please see (i) 27, Fig 3.9.2(a) and (ii) 27 in Figs 4.1]

Please read the following on-line White Papers for more details at www.samlexamerica.com (Home > Support > White Papers):

- “Neutral to Ground Switching in RV and Marine Applications”

4.4.2 Operation of Transfer Relay and Output Neutral to Chassis Ground Bond Switching Relay

Refer to Schematic at Fig 4.1.

The Bi-directional Transformer is used as follows:

- o Feeds AC output from the Inverter Section when Grid power is not available.
- o Feeds Grid / Generator power to the Battery Charger Section when Grid / Generator input is available.

Switching of Hot Output (OUTPUT LINE)

- o 40A* rated SPDT Relay RY1 (Fig 4.1) is used to switch the Hot Output Connector (OUTPUT L) to either the Inverter Section or to Grid / Generator. (*Refer to Note 2 under Legend for Fig 4.1)
- o When Grid / Generator input Power is available, Relay RY1 (Fig 4.1) will be energized and contact 4 switches over to contact 5. The Bidirectional Transformer works as a battery Charger. The Hot AC input from Grid / Generator (INPUT L) is fed to the Hot input of the Bi-directional Transformer for battery charging and at the same time, it is passed through to the Hot Out (OUTPUT L) for powering the AC loads.
- o When Grid / Generator power fails, Relay RY1 (Fig 4.1) will be de-energized and contact 4 switches back to contact 3. Output from the Inverter Section is fed to the Bi-directional Transformer and onwards to the Hot Out (OUTPUT L) for powering the AC loads.

SECTION 4 | General Description & Principles of Operation

Switching of Bonding of Output Neutral to Chassis Ground

- o 40A* rated SPDT Relay RY2 (Fig 4.1) is used to switch the bonding of the Output Neutral Connector (OUTPUT N) to the chassis of the unit. (*Refer to Note 2 under Legend for Fig 4.1)
- o When Grid / Generator input power is available, Relay RY2 (Fig 4.1) will be energized and contact 4 switches over to contact 5. Neutral input from Grid (GRID N) is fed to the Neutral input of the Bi-directional Transformer for battery charging and at the same time, it is passed through to the Output Neutral (OUTPUT N) for powering the AC loads. Please note that in this condition, the Output Neutral (OUTPUT N) is isolated from the chassis of the unit
- o When Grid / Generator input power fails, Relay RY2 (Fig 4.1) will be de-energized and contact 4 switches back to contact 3. Neutral output from the Inverter Section is fed the Neutral of the Bi-directional Transformer and onwards to the output Neutral (OUTPUT N) for powering the AC loads. At the same time, the output Neutral (OUTPUT N) gets bonded to the metal chassis of the unit through the mated contacts of the Insulated Male / Female Quick Disconnect (27, Fig 4.1) located in the AC Wiring Compartment [27, Fig 3.9.2(a)] in EVO-1212F-HW / 1224F-HW. In EVO-1212F / 1224F, the Insulated Male / Female Quick Disconnect is accessible after opening the top cover of the unit.

SECTION 4 | General Description & Principles of Operation

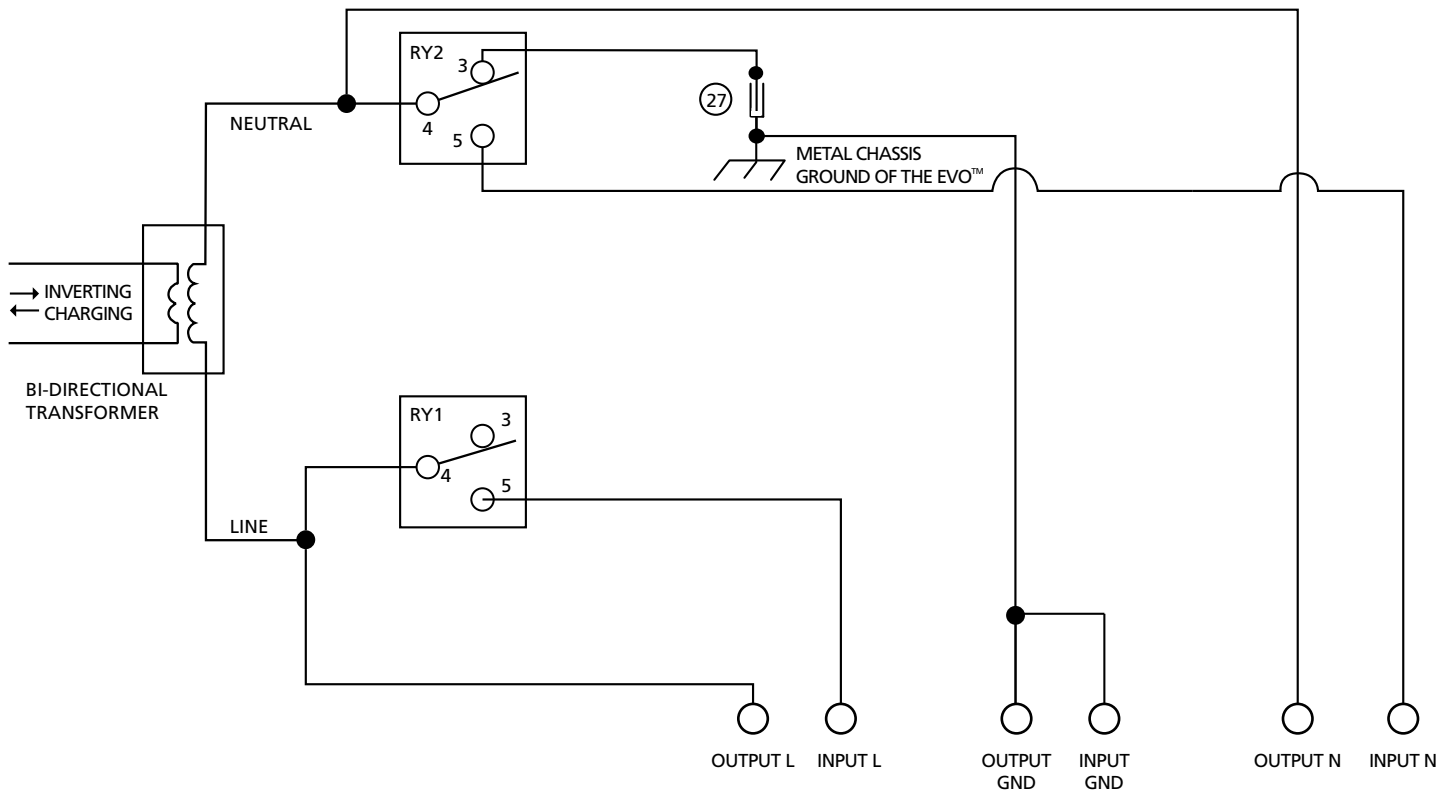

Fig 4.1 Operation of Transfer Relay and Switching of Bond Between Output Neutral and Metal Chassis Ground

LEGEND for Fig 4.1

RY1	Transfer Relay (40A - See Note 2 below) (Shown in de-energized state). Transfers the Line Conductor of the AC load to either the Line Conductor of the input from Grid / Generator or to the Line Conductor of the Inverter Section.
RY2	Relay (40A - See Note 2 below) for Neutral to Ground bond Switching
4, 3	Normally Closed Contacts (Shown in de-energized state)
4, 5	Normally Open Contacts (Shown in de-energized state)
27	Insulated Male / Female Quick Disconnect [27, Fig 3.9.2(a)] for disconnecting Output Neutral to Chassis Ground bond in Inverting Mode (Default - connected)

- NOTES:**
1. Relays are de-energized in Inverting Mode and are energized in Charging Mode.
 2. Although relays RY1, RY2 are rated for 40A, AC input current and output pass through current in charging mode are limited to 20A & 15A respectively by the 20A input breaker and 15A output breaker.

SECTION 4 | General Description & Principles of Operation

4.2.2.1 Synchronized Transfer of Power

4.4.2.1.1 General information

When the frequency and phase of output voltages of two AC power sources are the same (in sync), the two AC sources are considered to be “synchronized”.

Critical AC loads require un-interruptible AC input power. It is, therefore, necessary that when the primary AC input power is interrupted / fails, the load should be transferred to the backup AC source “very quickly” within the “holdup time” of the load(s).

When AC power feeding motors or inductive loads like transformers etc. is interrupted / fails, residual voltage is induced in the load due to “generator effect” created by a rotating motor or by the stored energy released from the inductive loads like transformer’s windings or core. The induced residual voltage in the load has the same frequency and phase as the voltage of AC input power when it failed and, this voltage does not dissipate immediately but within a few seconds. This induced residual voltage in the load can cause extremely high inrush currents to occur when such loads are “very quickly” transferred to a “non-synchronized” source of backup AC power (the loads are transferred to the “non-synchronized” backup source before the residual voltage in the load(s) has dissipated). The resulting effect, frequently described as “bumping” can initiate nuisance tripping of circuit protective devices or in extreme cases, cause mechanical damage to motor shaft and couplings. To prevent this abnormal operating condition when the load is transferred between the primary and backup AC sources “very quickly (normally within around 16 ms)”, it is to be ensured that the voltage of the backup AC power source is always kept “synchronized” with the voltage of the primary AC power source.

Synchronization control logic used in a backup AC source is required to be based on the frequency stability characteristics of the primary AC source which can be Grid or Generator. The frequency of Grid voltage is very stable. On the other hand, the frequency of Generator voltage (except Inverter Generators) may vary considerably depending upon the performance of its Speed Governor that compensates for the drop in RPM / frequency when electrical load is switched on / increased or, rise in RPM / frequency when electrical load is decreased / switched off.

4.4.2.1.2 Synchronization Algorithm Options

When operating as an Inverter Charger, the EVO is designed to accept external AC input power through AC Power Inlet (9, Fig 2.1) in EVO-1212F/ 1224F and through AC Input Terminals (21,22,23 in Fig 2.3) in EVO-1212F-HW/ 1224F-HW.

The frequency and phase of the internal backup Inverter Section are always kept synchronized with the AC input source. This facilitates “extremely fast” transfer time of up to 16 ms. Also, transfer from the Inverter Section to the AC input source and vice versa takes place at zero crossing of the voltage waveform – this ensures (i) negligible arcing / erosion of Transfer Relay contacts and (ii) negligible Electromagnetic Interference (EMI) associated with arcing.

Programming parameters “SYNCHRONIZATION” has been provided with two synchronization algorithm options each: (i) 0= Fine, or (ii) 1= Coarse as shown in TABLE 4.1. Option “0 =Fine” is recommended for AC input power source that has more stable output frequency like Grid / Inverter Generator. Option “1= Coarse” is recommended for AC input power source with less stable output frequency like Generator.

SECTION 4 | General Description & Principles of Operation

TABLE 4.1 SYNCHRONIZATION ALGORITHM OPTIONS ON AC INPUT CONNECTIONS

AC Input Connection	Synchronization Algorithm Options			
	AC Input Source is Grid or Inverter Generator		AC Input Source is Generator	
	Programming Parameter	Option	Programming Parameter	Recommended Option
EVO-1212F/ 1224F AC Inlet (9, Fig 2.1)	SYNCHRONIZATION (See NOTE 1)	0=Fine (Default)	SYNCHRONIZATION (See NOTE 1)	Change to Option "1=Coarse"
EVO-1212F-HW/ 1224F-HW AC Input Terminals (21,22,23 in Fig 2.3)				
NOTES:				
1. For programming details for parameter "SYNCHRONIZATION", please refer to Section 4.5.2.8 in EVO-RC-PLUS Remote Control Manual				

4.4.2.1.3 Transfer From Inverter Section to AC Input Source

When power from AC input source is made available, its voltage and frequency are monitored for 2 sec to check if these are within the programmed limits. If yes, the output voltage of the Inverter Section is synchronized with the AC input source. This synchronization process takes few seconds. Once synchronization is completed, the load is transferred instantly (within 1 ms) to the AC input source at Zero Crossing of the voltage waveform for safer transfer and for better protection of Transfer Relay contacts. The unit now operates in "Charging Mode" with the AC power from the AC input source charging the batteries as well as providing power to the AC loads.

4.4.2.1.4 Transfer From AC Input Source to Inverter Section

When the unit is operating in "Charging Mode" with the AC input source charging the batteries as well as providing power to the AC loads, the phase and frequency of the AC input source are tracked continuously. In case AC input source fails or is disconnected, the inverter will be forced to transfer at voltage which is at the same phase and frequency at which the AC input source had been disconnected. Load will be transferred to the inverter within 16ms at zero crossing. The unit will now work in "Inverting Mode" and the batteries will start discharging.

4.5 BATTERY CHARGER SECTION

The Battery Charger Section of these units provide 2/3/4 stage charging with 7 programmable charging profiles as detailed at Section 5.6. The same Isolation Transformer and the H-Bridge configuration of the Inverter Section are used to work in the reverse direction, i.e. the AC input is stepped down and rectified to the programmed DC battery charging voltage using Pulse Width Modulation (PWM) Control. That is why it is called a Bi-directional device. Further, the charging voltages and currents are programmable to take care of a wide range of battery types like Lead Acid, Nickel-Zinc (Ni-Zn) & Lithium Ion.

Important battery charging features are as follows:

- Adaptive Charging Control for 2 Charging Profiles out of the 7 profiles
- Dynamic Input Power Diversion Control
- Parallel charging through External Charge Controller

SECTION 4 | General Description & Principles of Operation

- Temperature compensated charging
- Programmable Charging Profiles for Lead Acid, Nickel-Zinc (Ni-Zn) and Lithium Batteries

Please see details under Section 5 titled “Battery Charging in Evolution™ Series”.

4.6 MODES OF OPERATION

4.6.1 Charging Mode

As long as the external AC input power is available and is within the programmed limits of voltage and frequency, it is passed through to the AC load through the Transfer Relay Section. At the same time, the Battery Charger Section converts the external AC input power from the Grid/Generator to DC power to charge the DC Battery Source.

4.6.2 Inverting Mode

If at any instant, the external AC input power is interrupted or is not within the programmed limits of voltage and frequency, the Transfer Relay is de-energized and the load is transferred to the Inverter Section and internal battery charging is terminated. This is called the Inverting Mode.

4.6.3 Power Saving Mode

Power Saving Mode related to inverters is a function designed to conserve battery power when the inverter is in ON condition and no AC loads are connected to it or, AC loads are connected to it but have been switched OFF. This condition is also called “No Load Condition”.

When an inverter is operating under “No Load Condition”, it will consume a small amount of input power from the battery to keep all internal circuits alive and be ready to deliver the full rated output voltage and power to the load once the load is switched ON. This input power drawn from the battery when no load is being supplied by the inverter is called the “No Load Power Draw” (also called “Idle Power” or “Self Power Consumption”). This “No Load Power Draw” is proportional to the size of the inverter e.g. a 150 Watt inverter may have “No Load Power Draw” of around 6W and a 3000W may have “No Load Power Draw” of around 30W. This power is wasted and drains the battery unnecessarily. It is, therefore, desirable to reduce the “No Load Power Draw” to the minimum.

The “No Load Power Draw” of EVO-1212F/1212F-HW/1224F/1224F-HW in the Normal Operating Mode is around 20W.

The EVO has an optional programmable operating mode called “Power Saving Mode” that is designed to reduce this “No Load Power Draw” to less than 8W during conditions where the Inverter Section is ON but is not supplying any load [Applicable only when the unit is operating in “Inverting Mode”].

Enabling / disabling of “Power Saving Mode” is carried out using optional Remote Control Model EVO-RC-PLUS. The EVO is shipped with the “Power Saving Mode” option in “Disabled” condition [Programming Parameter “POWER SAVING” is set at “0=Disabled” in the Default condition – See Section 4.8.2.1 of the EVO-RC-PLUS Remote Control Manual].

When “Power Saving Mode” is enabled, the Inverter Section will NOT provide full rated output voltage of 120 VAC of Normal Operating Mode but pulsing output voltage consisting of 3, 60 Hz cycles of “reduced 48Vrms load search voltage” every 0.5 sec. This output voltage is used to “search” if a load is being powered and also to measure the power drawn by this load [The power drawn by the load will be initially measured based on pulsing output voltage].

SECTION 4 | General Description & Principles of Operation

consisting of 3, 60 Hz cycles of “reduced 48VAC load search voltage” every 0.5 sec and from there, the power will be calculated based on the rated output voltage of 120VAC for the Normal Operating Mode. Operation of the “Power Saving Mode” is controlled through the following programming parameters:

- **4.6.3.1 Parameter “ENTER POINT”** *[See Section 4.8.2.2 in the EVO-RC-PLUS Remote Control Manual]*

This parameter determines the threshold of power drawn by the load at which the EVO will exit the Normal Operating Mode (full 120VAC output voltage; No Load Power Draw from the battery will be 25-30W) and “enter” Power Saving Mode (output voltage consisting of 3, 60 Hz cycles of “reduced 48VAC load search voltage” every 0.5 sec; No Load Power Draw from the battery will be < 8W).

The programmable range of this parameter is 4-50Watts; Default value is 6W.

Whenever the Inverter Section is switched ON with “Power Saving Mode” in enabled condition, it will initially start in Normal Operating Mode *[Full 120VAC output voltage; No Load Power Draw from the battery will be 20W]*. It then measures the power drawn by the load, if any, based on Normal Operating Voltage of 120VAC. If the power drawn by the load is \leq the programmed power value of “Enter Point”, the Inverter Section will enter “Power Saving Mode” (pulsing output voltage consisting of 3, 60 Hz cycles of “reduced 48Vrms load search voltage” every 0.5 sec). It is, therefore, important to first determine the running power consumption of your load in Watts and then, ensure that the programmed value of parameter “ENTER POINT” is $>$ the running power of the load. If the running power of the load is $<$ the programmed value of parameter “ENTER POINT”, the load may turn ON initially due to higher initial startup surge power but will turn OFF when it starts drawing lower running power that is $<$ the programmed value of parameter “ENTER POINT”. (**NOTE:** The initial startup surge power of AC loads may be up to 10 times higher than their “running power” depending upon the type of AC load).

- **4.6.3.2 Parameter “WAKE UP POINT”** *[See Section 4.8.2.3 in the EVO-RC-PLUS Remote Control Manual]:*

Once the inverter enters “Power Saving Mode” as described at Section 4.8.3.1 above *[Output voltage consisting of 3, 60 Hz cycles of “reduced 48VAC load search voltage” every 0.5 sec; Power draw from the battery will be < 8W]*, it will continue to remain in this mode till the time the power drawn by the load is \geq than the programmed threshold of Parameter “WAKE UP POINT” *[Programmable range is 4-50Watts; Default is 7W]*. When the power drawn by the load \geq the programmed threshold of Parameter “WAKE UP POINT”, the EVO will wake up and change to the Normal Operating Mode (full 120VAC output voltage; No Load Power Draw from the battery will be 20W).

INFO

Power Saving Mode should be disabled for the following loads:

- Low power loads that draw less than 5W e.g. digital clocks, satellite receivers, phones / answering machines etc.
- Audio / video / computing devices that consume normal operating power $>$ 50 W but draw less than 5W on entering Sleep Mode when switched off or , when no activity is seen for a specified time.
- Some devices like small fluorescent lights, refrigerators, microwaves, computers and other sophisticated electronics may not be detected when scanned by the output voltage characteristics of the Power Saving Mode *[Output voltage consisting of 3, 60 Hz cycles of “reduced 48VAC load search voltage” every 0.5 sec]*. These devices have power supplies in their front end that do not present a load until the full 120VAC line voltage is available.

SECTION 4 | General Description & Principles of Operation

4.6.4 Power Saving Mode - Transfer Characteristics

- **Transfer from AC Input Source to Inverter:** If qualified AC input power is available (its voltage and frequency are within the programmed range), the Transfer Relay remains energized and the AC input power is passed through to the load and at the same time, the unit operates as a battery charger. If AC input power fails or is not qualified (its voltage and frequency are not within the programmed range), the Transfer Relay is de-energized and the load is transferred to the inverter. *When this transfer takes place, the inverter initially operates in Normal Mode.* If the AC load was greater than the programmed value of "Wake-up Point", the inverter continues in Normal Mode. However, if it sees a load less than the programmed value of "Enter Point" for around 5 sec, it enters Power Saving Mode.
- **Transfer from Inverter to AC Input Source:** As soon as qualified AC input power is available, the inverter will exit Power Saving Mode and will switch over to Normal Mode. *This switch over is necessary for synchronizing the AC output of the inverter with the AC input before transfer (Synchronization can not be carried out with pulsing wave form during Power Saving Mode).* After synchronization is completed, the load is transferred to the AC Input Source at zero crossing of the voltage waveform.

4.6.5 Normal (Off-Line), On-Line and Charger Only Modes

EVO has 3 modes of operation as follows that can be programmed through programming parameter "MODE" [*For details, see Section 4.4.2.13 in the EVO-RC-PLUS Remote Control Manual*]

- Option "0=Normal"** (Default). Also called Off-Line Mode. See details at Section 4.6.5.1 below
- Option "1=On-Line"**. See details at Section 4.6.5.2 below
- Option "2=Charger Only"**. See Section 4.6.5.3 below

4.6.5.1 Option "0=Normal" (Default). This option is also called "Off-Line UPS Mode" (UPS stands for **Un**-interruptible **P**ower **S**upply). In this mode, AC input source is the PRIMARY source of AC power and the batteries / Inverter Section of EVO is the BACK-UP source of DC-AC power. If qualified AC input (within the programmed voltage and frequency limits) is available, the EVO will operate in "Charging Mode" and qualified AC input will be passed through to the AC output and at the same time, the Internal AC Charger will start charging the batteries. If an external Solar Charge Controller is also connected to the External Charging Terminals (3, 4 in Fig 2.1), the internal AC Charger of EVO will limit the charging current as follows:

$$\begin{array}{l} \text{Value of charging current produced by EVO} \\ \text{Charging Section} \end{array} = \begin{array}{l} \text{(Programmed value of charging current set by} \\ \text{parameter "BULK CURRENT" [*See Section 4.4.2.1} \\ \text{of EVO-RC-PLUS Remote Control Manual*]} \text{ minus} \\ \text{(Value of current fed from the external solar charge} \\ \text{controller)} \end{array}$$

When AC input fails or, is not within the programmed values of voltage and frequency, the unit will change over to "Inverting Mode" and the AC Output will be fed from the internal Inverter Section of EVO. When the AC input is restored, the EVO will revert back to "Charging Mode" to charge the batteries and at the same time, pass through the AC input to the AC output.

SECTION 4 | General Description & Principles of Operation

4.6.5.2 Option "1= On-Line": This option is also called "On-Line UPS Mode" (UPS stands for **U**n-interruptible **P**ower **S**upply). In this mode, the Inverter Section of the EVO is the PRIMARY DC-AC source of power. The AC input source is the BACK-UP source of AC power. In this mode, even if qualified AC input is available (within the programmed voltage and frequency limits), the EVO will still operate in "Inverting Mode" and AC output will be provided by the Inverter Section as long as the batteries are in charged condition above the specified programmed value of low battery voltage that is set through programmable parameter "LOW VOLT ALARM" [*See Section 4.4.2.8 of EVO-RC-PLUS Remote Control Manual*]. When the battery discharges to the programmed voltage threshold of "LOW VOLT ALARM", or lower and remains at this threshold, or below for a sustained programmed time period set by programmable parameter "GS DETECT TIME" [*See Section 4.4.2.16 of EVO-RC-PLUS Remote Control Manual*], the EVO will change over to "Charging Mode". On changing over to "Charging Mode", qualified AC input will be passed through to the AC Output and at the same time, the Internal AC Charger will start charging the battery. If an external Solar Charge Controller is also connected to the External Charging Terminals (3, 4 in Fig 2.1), the internal AC Charger will limit the charging current as follows:

$$\begin{array}{l} \text{Value of charging current produced by EVO} \\ \text{Charging Section} \end{array} = \begin{array}{l} \text{Programmed value of charging current set by} \\ \text{parameter "BULK CURRENT" [*See Section 4.4.2.1} \\ \text{of EVO-RC-PLUS Remote Control Manual*] minus} \\ \text{(Value of current fed from the external solar charge} \\ \text{controller)} \end{array}$$

Under the following 2 conditions, "Charging Mode" will be terminated, and the EVO will switch back to "Inverting Mode". Switching from "Charging Mode" back to "Inverting Mode" has 2 options under programming parameter "ONLINE OPTION" [*See Section 4.4.2.14 of EVO-RC-PLUS Remote Control Manual*]:

- i. When Parameter "**ONLINE OPTION**" is set at option "0= Option 1" [*See Section 4.4.2.14 of EVO-RC-PLUS Remote Control Manual*]:

EVO™ will switch back from "Charging Mode" to "Inverting Mode" after completion of 3-Stage/ 2-Stage charging profile programmed through parameter "CHARGING PROFILE" [*See Section 4.4.2.21 in the EVO-RC-PLUS Remote Control Manual*]

- ii. When Parameter "**ONLINE OPTION**" is set at option "1= Option 2" [*See Section 4.4.2.4 in the EVO-RC-PLUS Remote Control Manual*]:

EVO™ will switch back from "Charging Mode" to "Inverting Mode" when the batteries have charged to the voltage threshold set by parameter "RESET VOLTAGE" [*See Section 4.4.2.7 in the EVO-RC-PLUS Remote Control Manual*] and have remained at this threshold or higher for time period set by parameter "GEN OFF DELAY" [*See Section 4.4.2.18 in the EVO-RC-PLUS Remote Control Manual*].

SECTION 4 | General Description & Principles of Operation



Online Mode is suitable for installations where both Grid and Photovoltaic (PV) Solar Battery Charging System are available. It is also desirable in areas where Grid / Utility Energy Rates are very high and use of supplementary battery based photovoltaic power system is more cost effective.

4.6.5.3 Option "2=Charger Only".

In Off-grid DC powered homes, for efficiency consideration, all lighting and other loads / appliances are normally powered from batteries that are primarily charged through solar / wind power. Generator backup is used for powering AC to DC battery charger for charging the batteries during extended periods of cloudy / no wind conditions. To meet this requirement, the EVO™ can be programmed to operate as a battery charger ONLY i.e. when AC input power is available within the programmed limits of voltage and frequency, charging will take place and AC input will be passed through to the load(s). The unit will NOT transfer to Inverting Mode if AC input fails or is outside the programmed limits of voltage and frequency *[For details, see Section 4.4.2.13.3 of EVO-RC-PLUS Remote Control Manual]*.

4.7 TEMPERATURE SENSOR FOR BATTERY CHARGING

Battery Temperature Sensor Model EVO-BCTS [Fig 2.5(a)] has been provided to ensure optimum charging of Lead Acid/ Nickel-Zinc (Ni-Zn) batteries by modifying the charging voltages based on temperature if the battery sees very wide temperature swings. See Section 5.5 for details. Temperature compensation can be programmed with the help of optional Remote Control EVO-RC *[See Section 4.4.2.5 of EVO-RC-PLUS Remote Control Manual]*. Range is -3 to -4 mv/ °C/cell (Default is -4 mv/ °C/cell). Without temperature compensation, the battery life is likely to be drastically reduced because the battery will be undercharged during cold conditions (will build up sulfation) or will be overcharged during hot conditions (will boil and lose excessive water). *See Section 1.4.5 for more details on temperature compensation.*



1. Lithium Ion Battery charging does not require temperature compensation. Hence, do not use EVO-BCTS Temperature Sensor when charging Lithium Ion Batteries.
2. Automatic temperature compensation using EVO-BCTS Temperature Sensor is designed for Lead Acid Batteries based on programming parameter "COMPENSATE" *[See Section 4.4.2.5 in EVO-RC-PLUS Remote Control Manual]*. When charging Nickel-Zinc (Ni-Zn) batteries, ensure that the value of programming parameter "COMPENSATE" is set based on approximate linear compensation for the particular Ni-Zn battery.

SECTION 4 | General Description & Principles of Operation



ATTENTION!

1. Le chargement au lithium-ion ne nécessite pas de compensation de température. Par conséquent, n'utilisez pas le capteur de température EVO-BCTS lors du chargement de batteries au lithium-ion.
2. La compensation automatique de température à l'aide du capteur de température EVO-BCTS est conçue pour les batteries au plomb selon le paramètre de programmation "COMPENSATE" [voir la section 4.4.2.5 du manuel de la télécommande EVO-RC-PLUS]. Lors de la charge en nickel-zinc (Ni-Zn) batteries, assurez-vous que la valeur du paramètre de programmation "COMPENSATE" est définie sur la base d'une compensation linéaire approximative pour la batterie Ni-Zn concernée.

4.8 PARALLEL OPERATION WITH EXTERNAL SOLAR CHARGE CONTROLLER

The Battery Charger Section is able to operate in parallel with external Solar Charge Controller with a charging capacity of up to 50 A. The output of the external charging source is routed through this unit and operates in parallel with the internal charger. The internal charging current is controlled to ensure that the combined current fed to the battery does not exceed the programmed value of parameter "BULK CURRENT" [See Section 4.4.2.1 in the EVO-RC-PLUS Remote Control Manual]. This improves the life of the battery. *Please see Section 5.4 for more details.*

4.9 COOLING AND OVER TEMPERATURE PROTECTION

4.9.1 Cooling Fans

The unit is cooled by convection and by forced air cooling using 2 variable speed cooling fans. Temperature is sensed at the Power Transformer and H-Bridge Power Mosfets / Heat Sink. The fans will be switched ON at specified temperatures measured at the above sense points. The speed of the fans is increased as the temperature rises.

4.9.2 Over Temperature Protection

[Refer to Fault Messages and Troubleshooting Guide at Table 7.1 of EVO-RC-PLUS Remote Control Manual]. The unit goes to Fault Mode and shuts down due to over temperature sensed at the Main Power Transformer and the Heat Sink for the Power Mosfets: Fault messages and temperature thresholds for shut down and auto-reset are as follows:

- **"Transformer over heat!"** : Shut down at 150°C and auto-reset at 80°C
- **"Heat sink over heat!"** : Shut down at 100°C and auto-reset at 60°C

4.9.3 Automatic Reduction Of Charging Current In Higher Ambient Temperatures

In order to protect against over temperature shut down when operating in higher ambient temperatures of 50C to 60C, the BULK CURRENT setting [See Section 4.4.2.1 in the EVO-RC-PLUS Remote Control Manual] is automatically reduced as follows based on temperature sensed at the Power Transformer and at the Heat Sink for the Power Mosfets:

SECTION 4 | General Description & Principles of Operation

- **Power Transformer:** In case the temperature is $>130^{\circ}\text{C}$, the BULK CURRENT setting is automatically reduced by 0.2% every 20 sec
- **Heat Sink:** In case the temperature is $>90^{\circ}\text{C}$, the BULK CURRENT is automatically reduced by 0.2% every 20 sec

4.10 OPTIONAL REMOTE CONTROL EVO-RC FOR PROGRAMMING OF MODES OF OPERATION AND PARAMETERS

Optional Remote Control Model EVO-RC-PLUS [Fig 2.4(a)] will be required for more advanced control and monitoring. *Please see separate Owner's Manual for EVO-RC-PLUS.* The Remote Control comes with 10M / 33 ft., RJ-45 Data Cable. The Remote plugs into RJ-45 Jack on the front panel of the unit (7, Fig 2.1). It has provision for Data Logging using SD Card of up to 16 GB (FAT16 / FAT32). It also has its own Real Time Clock and Super Capacitor Type of Internal Battery. The Remote Control will be required for Firmware upgrade through the SD Card.

Detailed messaging is available through its LCD display and LEDs. This remote will also be required for programming of various parameters to suit specific requirements. Each programmable parameter has a Default Value. **This unit has been shipped with the various parameters set at the Default Values.** *Programmable and Default values are shown in Tables 6.2 to 6.6.*

SECTION 5 | Battery Charging in Evolution™ Series

5.1 PRINCIPLES OF OPERATION OF BATTERY CHARGING SECTION



For background information on batteries and charging process, please read Section 1.4, "General Information - Battery Related". All battery charging voltages are specified at battery temperature of $25^{\circ}\text{C} / 77^{\circ}\text{F}$.

5.1.1 General Information

EVO Series is a Low Frequency Type, Pure Sine Wave, Single Phase Inverter-Charger with a built-in Transfer Relay. It uses high performance, 100MHz SP (Digital Signal Processing) type of micro-controller and Pulse Width Modulation (PWM) control. It is Bi-Directional i.e. it uses a *common Converter Section* consisting of Low Frequency Isolation Transformer and Mosfet based H-Bridge that can work in two directions as follows:

- 1) **AC to DC Charging Mode:** The common Converter Section is used to convert external AC input power to DC output power to charge the batteries and at the same time, pass through the AC input power to the AC loads
- 2) **DC to AC Inverting Mode:** The common Converter Section is used to convert DC input power from the batteries to AC output power to feed the AC loads

SECTION 5 | Battery Charging in Evolution™ Series



INFO

Please note that as the unit is Bi-Directional with a common Converter Section as explained above, it cannot work as inverter and charger at the same time

During “Charging Mode”, the internal Transfer Relay is energized when AC input power from Grid / Generator is within the programmed limits of voltage and frequency and the following actions are initiated:

- AC input power is fed to the Common Converter Section for conversion to DC voltage to charge the batteries
- AC input power is simultaneously passed through to the AC loads

5.1.2 Basics of PWM (Pulse Width Modulation) Based Charging Process

5.1.2.1 AC input power is fed to the Primary Winding of the Isolation Transformer. The voltage on the Secondary of the isolation Transformer is stepped down and fed to input of H-Bridge Converter that uses four N-Channel Mosfet Switches. The output of the H-Bridge is fed to the battery / battery bank. PWM (Pulse Width Modulation) technique is used for the charging process. PWM frequency is 30 kHz

5.1.2.2 The two High-Side Mosfet Switches of the H-Bridge are kept OFF and their Body Diodes are used for full-wave rectification of the stepped down AC input voltage. The average / mean value of battery charging current will vary between 0A and a Positive peak value in the form of DC Wave resembling sine wave. The charging current displayed by the EVO-RC Remote Control will be the average / mean value of the above DC Wave

5.1.2.3 The two Low-Side Mosfet Switches of the H-Bridge are switched ON / OFF together at PWM frequency of 30 kHz with variable “Duty Cycle” proportional to the desired value of charging current. When the two Low-Side Mosfets are ON for period determined by the “Duty Cycle” set by the micro-controller, the Secondary Winding will be short circuited and magnetic field proportional to the short circuit current will be created by the winding. When the two Low-Side Mosfet Switches are switched OFF, short circuit of the winding is removed resulting in collapse of the magnetic field and generation of induced voltage pulses at PWM frequency of 30 kHz with a value = $-L \frac{di}{dt}$ where “L” is the Inductance of the winding and “di/dt” is the rate of decay of Short Circuit Current. Thus, higher Duty Cycle will produce induced pulses with higher voltage. When the voltage of the induced pulses is > the battery voltage, charging current pulses will be produced. The value of charging current pulses will be proportional to the difference of voltage between the voltage of the induced pulses and the battery voltage

5.1.2.4 During the Bulk Stage of charging (Section 5.7.1.1), the average / mean charging current set by programming parameter “BULK CURRENT” [See section 4.4.2.1 of EVO-RC-PLUS Remote Control Manual] is held constant by controlling the “Duty Cycle” of the 30 kHz induced pulses.



INFO

When charging starts, the charging current is NOT increased to the programmed value of parameter BULK CURRENT immediately but is gradually ramped up to this value

5.1.2.5 During Absorption Stage (Section 5.7.2), Float Stage (5.7.3) and Equalization Stage (5.8.2.3), the battery voltage is held constant indirectly by controlling the “Duty Cycle” of the 30 kHz induced pulses. For example, if the

SECTION 5 | Battery Charging in Evolution™ Series

battery voltage increases above the value set by parameters ABSORP VOLTAGE / FLOATING VOLTAGE / EQUALIZE VOLTAGE, the PWM “Duty Cycle” is reduced that leads to lower short circuit current of the Secondary Winding. This will reduce the voltage of the induced pulses and consequently, reduce the value of the charging current pulses. Reduced value of charging current pulses will reduce the battery voltage back to the value set by ABSORP VOLTAGE / FLOATING VOLTAGE / EQUALIZE VOLTAGE

5.1.2.6 Battery Charging Profiles

7 programmable types of 2/3/4 Stage Charging Profiles are available. Please see details under Section 5.6

5.2 DYNAMIC AC INPUT CURRENT DIVERSION CONTROL BETWEEN AC PASS THROUGH CURRENT AND BATTERY CHARGING CURRENT

EVO Models have very powerful Battery Charger Section that will require very high AC input current from the AC input source (See Table 5.1).

	Rated Charging Current		Maximum Pass Through Load Power and Current	
	Max. DC Side Charging Current	Equivalent AC Side Charging Current	Pass Through Power	Pass Through Amps
EVO-1212F & EVO-1212F-HW	60A	11.2A	1200 VA	10A
EVO-1224F & EVO-1224F-HW	40A	11.2A	1200 VA	10A

When batteries are being charged at or near the maximum value of charging current (See TABLE 5.1) and the pass through load current increases, the AC input supply circuit breaker may trip if the combined value of the AC side charging current (equivalent to the DC side charging current) and the pass through load current exceeds the AC input supply circuit breaker capacity. This situation is prevented by “Dynamic AC Input Current Diversion Control between AC Pass through Current and Battery Charging Current”. This is accomplished through appropriate setting of programmable parameters “GRID MAX CURRENT”. Optional Remote Control Model EVO-RC-PLUS will be required for the above setting *[Please refer to Section 4.5.2.2 of the EVO-RC-PLUS Remote Control Manual]*.

“GRID MAX CURRENT” (Default = 20A) should be set equal to the Ampere rating of the external AC input supply breakers. During Battery Charging Mode, if the AC pass through load current is increased resulting in the net AC input current increasing by 1A more than the programmed “GRID MAX CURRENT” for 1 sec, the **EVO will automatically reduce the charging current to ensure that the equivalent AC Side Charging Current + Pass Through Load Current is not more than the set value of “GRID MAX”**.



INFO

As explained above, if the net AC input current is 1A more than the value of GRID MAX CURRENT for 1 sec, the AC side charging current is clawed back to ensure that GRID MAX CURRENT value is not exceeded. If the value of pass through load current increases to a value of 1A more than the programmed value of GRID MAX CURRENT for 5 sec, input over current protection will be activated based on option to either transfer to Inverting Mode or to shut down in FAULT MODE *[Refer to details of these 2 options under parameter “INPUT OC PROTECT” at Section 4.5.2.10 in the EVO-RC-PLUS Owner’s Manual]*

SECTION 5 | Battery Charging in Evolution™ Series

EXAMPLE:

- 1) Assume EVO-1212F is connected to the Grid input with Grid input supply circuit breaker capacity of 20A. Parameter settings are as follows:
 - a) "GRID MAX CURRENT" setting = the Default value of 20A.
 - b) "BULK CURRENT" setting = 60A (DC). When charging at 60A on the DC side, the corresponding AC side input current will be 11.2A (Based on Conversion Factor of 1A DC side charging current = 0.19A AC side charging current).
- 2) Assume that the AC pass-through load current is 5A. The total AC input current will be 16.2A i.e. 5A AC pass-through load current + 11.2A AC input side current corresponding to 60A DC side charging current [see 1(b) above]. Under this condition, the EVO will operate normally because the net AC input current of 16.2A will be below 20A Default setting for parameter "GRID MAX CURRENT"
- 3) If now, the AC pass-through load current is increased to 15A for more than 5 sec, the total AC input current will be 26.2A i.e. 15A pass through load current + 11.2A AC side charging current corresponding to 60A DC side charging current [see 1(b) above]. As the total AC input current will be 6.2A more than the "GRID MAX CURRENT" for more than 1 sec, the AC input side charging current will be clawed back from 11.2A to 8.8A within less than 5 sec so that the total AC input current is limited to 20A. At reduced AC side charging current of 8.8A, the corresponding DC side charging current will be 46.3 A DC (Based on Conversion Factor of 1A DC side charging current = 0.19A AC side charging current).
- 4) If now, the AC pass-through load current is increased to 22A for more than 5 sec, the total AC input current will be 30.8A (22A pass through load current + 8.8A AC side charging current corresponding to 46.3A DC side charging current) . The AC side charging current will be automatically reduced from 8.8A (corresponding to 46.3A DC side charging current) to 0A (corresponding to 0A DC side charging current). However, now the AC input current will be still be 22A i.e. 2A more than the "GRID MAX" current setting of 20A for more than 5 sec. After 5 sec of operation under this condition, the EVO will operate as follows based the option selected through parameter "INPUT OC PROTECT" *[See details of this parameter under Section 4.5.2.10 in EVO-RC-PLUS Owner's Manual]*
 - o **Parameter "INPUT OC PROTECT" set in the Default option "0=Inverter"**: The EVO will switch over to Inverter Mode to ensure that 22A AC load is maintained. If subsequently, the load reduces to 1A less than the 20A setting of GRID MAX CURRENT for 5 sec, the EVO will switch back to Charging Mode
 - o **Parameter "INPUT OC PROTECT" set for option "1= Shutdown": EVO will be shut down.**
 - There will be no AC output because the Transfer Relay will be de-energized, charging will be stopped and PWM drive to the Inverter Section will be switched off
 - Fault message "Input over current" will be displayed on the LCD screen, Blue LED marked "Status" will be switched off and Red LED marked "Fault" will be switched on
 - **The unit will be latched in OFF condition and will require manual reset by powering off the unit, waiting for 1 min and then powering on again**

5.3 AUTOMATIC REDUCTION OF CHARGING CURRENT IN HIGHER AMBIENT TEMPERATURES

In order to protect against over temperature shut down when operating in higher ambient temperatures of around 50C to 60C, the BULK CURRENT setting *[See section 4.4.2.1 of EVO-RC-PLUS Remote Control Manual]* is automatically reduced as follows based on temperature sensed at the Power Transformer and at the Heat Sink for the Power Mosfets:

SECTION 5 | Battery Charging in Evolution™ Series

- **Power Transformer:** In case the temperature is >130C, the BULK CURRENT setting is automatically reduced by 0.2% every 20 sec.
- **Heat Sink:** In case the temperature is >90C, the BULK CURRENT setting is automatically reduced by 0.2% every 20 sec.

5.4 PARALLEL CHARGING USING EXTERNAL SOLAR CHARGER

The batteries feeding the EVO™ can also be charged using appropriately sized external solar charging system. The output of the solar panels will feed to an appropriately sized external Solar Charge Controller. Output of the external Solar Charge Controller is fed to the input terminals marked "EXT Charger" (3,4 in Fig 2.1). **Maximum charging current on these terminals is to be limited to 50A. This limit should not be exceeded!**

The charging current received from the external Solar Charge Controller is directly fed to the battery terminals (1,2 in Fig 2.1) through a series connected Hall-effect Current Sensing IC with integrated shunt. The value of this current is displayed as "BATT EXT" on the optional Remote Control EVO-RC-PLUS. *Refer to following display screens from EVO-RC-PLUS Remote Control Manual.*

- During Inverting Mode: Screen No.5 in Fig 3.2(a) under Section 3.6.3.1 of EVO-RC-PLUS Remote Control Manual
- During Charging Mode: Screen No.1 in Fig 3.3(a) of EVO-RC-PLUS Remote Control Manual
- During Power Save Mode: Screen No.5 in Fig 3.4(a) of EVO-RC-PLUS Remote Control Manual

When AC input is available within the programmed window of AC input voltage and frequency, the batteries will be charged based on the following options selected through programming parameter "EXT. CHARGER":

i) Programming Parameter "EXT. CHARGER" set at Default Option "0 = Affect" (*Section 4.4.2.24 of Remote-Control Manual EVO-RC-PLUS*):

This is the default setting. Under this setting, the total charging current will be as follows:

- **Total Charging Current** = Charging current from internal AC charger **PLUS adjusted** charging current from the External Solar Charge Controller
 - **Adjusted Charging current from the Internal AC Charger** = Programmed value of Parameter "BULK CURRENT" (*Section 4.4.2.1 of Remote-Control Manual for EVO-RC-PLUS*) **MINUS** value of charging current from the External Solar Charge Controller

i) Programming Parameter "EXT CHARGER" set at Option "0 = Not affect" (*Section 4.4.2.24 of Remote Control Manual EVO-RC-PLUS*):

- **Total Charging Current** = Charging current from internal AC charger **PLUS** charging current from the External Solar Charge Controller
 - **Charging current from internal AC Charger** = Full programmed value of Parameter "BULK CURRENT" (*Section 4.4.2.1 of Remote Control Manual for EVO-RC-PLUS*)

The subsequent explanation is for **Programming Parameter "EXT. CHARGER" set at Default Option "0 = Affect"**

The net Bulk Charging Current fed to the battery bank will, thus, be as follows:

- Net Bulk Charging Current fed to the battery bank= Adjusted Bulk Charging Current from the internal Battery Charging Section + Current available from the external Solar Charge Controller

SECTION 5 | Battery Charging in Evolution™ Series

Normally, Lead Acid batteries should not be charged at very high Bulk Charging Current as this will damage the batteries due to overheating and cell degradation. Normal Bulk Charging Current is in the range of 10% to 20% of the Ah capacity of the battery bank at C/20 Discharge Rate. Check with the battery manufacturer regarding recommended Bulk Charging Current for your battery bank. This value of "Bulk Charging Current" should be programmed as "BULK CURRENT" using the optional Remote Control EVO-RC-PLUS [Refer to Section 4.4.2.1 in the Owner's Manual for EVO-RC-PLUS Remote Control].

The measured value of the charging current received from the external Solar Charge Controller is monitored by the control circuitry of the internal Battery Charging Section. The amount of Bulk Charging Current produced by the internal Battery Charging Section is adjusted in real time to satisfy the following condition:

- Internal Bulk Charging Current = Programmed Value of "Bulk Current" – External Charging Current
For example, if the "Bulk Current" in the EVO™ is programmed at say 40A and the external Solar Charge Controller is generating 15A, the internal Battery Charging Section will reduce its current from 40A to 25A so that the net charging current is equal to the programmed value of 40A.

In other Inverter Chargers where this design feature is not available and the Bulk Charging Current of the internal Battery Charger Section is fixed, the batteries are likely to be charged at high Bulk Charging Current = Fixed value of Bulk Charging Current from the internal Battery Charging Section + Current available from the External Charge Controller.



CAUTION!

Ensure that charging voltage related parameters of EVO™ like (i) ABSORP VOLTAGE, (ii) EQUALIZE VOLTAGE, (iii) FLOAT VOLTAGE and (iv) Temperature Compensation (COMPENSATE) are set / programmed to match the programmed parameters of the external charge controller. [Please refer to (i) Table 6.2, Section 6 and (ii) Sections 4.4.2.2 to 4.4.2.5 of the EVO-RC-PLUS Remote Control Manual].



ATTENTION!

S'assurer que la charge de tension, les paramètres connexes d'EVO™ comme (i) La tension d'absorption, (ii) EQUALIZE VOLTAGE, (iii) Tension d'égaliser et (iv) La compensation de température (COMPENSATE) est réglée / programmée pour correspondre aux paramètres programmés du contrôleur de charge externe. [Veuillez consulter (i) le tableau 6.2, section 6 et (ii) les sections 4.4.2.2 à 4.4.2.5 du manuel d'utilisation de la télécommande EVO-RC-PLUS].

SECTION 5 | Battery Charging in Evolution™ Series

5.5 BATTERY TEMPERATURE COMPENSATION USING TEMPERATURE SENSOR: MODEL NO. EVO-BCTS

5.5.1 General Description – Battery Temperature Compensation

Please refer to Section 1.4.5 for general information on temperature compensation of battery charging voltages.

Battery Temperature Sensor Model EVO-BCTS [Fig 2.5(a)] has been provided to ensure optimum charging of Lead Acid and Nickel Zinc (Ni-Zn) Batteries by **negative** temperature compensation of the charging voltages based on the battery electrolyte temperature. The charging voltage is reduced when electrolyte temperature rises above the reference temperature of 25°C / 77°F and increased when electrolyte temperature falls below the reference temperature of 25°C / 77°F.



Charging voltages of Lithium Ion Battery are not affected by temperature and hence, Battery Temperature Sensor Model EVO-BCTS is not required to be used when Lithium Ion batteries are used.

Automatic temperature compensation will be carried out over temperature range of -20°C to +60°C based on the programmed value of the **negative** "Temperature Coefficient of Battery Charging Voltage". In EVO, this parameter is called "COMPENSATE" and is specified in "mV/C/Cell". For programming details of this parameter, please refer to the following Sections of EVO-RC-PLUS Remote Manual:

- Parameter Setup Menu Map at Fig 4.2: Screen 5
- Programming range and defaults: Screen No. 5 of Table 4.3
- Programming procedure: Section 4.4.2.5

In addition to compensating Absorption, Float and Equalization voltages, the voltage thresholds of parameters "LOW VOLTAGE ALARM", "BATTERY LOW VOLTAGE", "RESET VOLTAGE", "BATTERY OVER VOLTAGE" and "RESET TO BULK" are also temperature compensated.

5.5.2 Constructional Details of Battery Temperature Sensor Model EVO-BCTS and Installation

The Temperature Sensor consists of 5 meters / 16.5 ft cable with Temperature Sensor Head for the battery end [1 in Fig 2.5(a)] and RJ-45 Plug [2 in Fig 2.5(a)] for EVO end.

Temperature Sensor Head [1 in Fig 2.5(a)]: The Temperature Sensor Head is installed on the Positive / Negative battery Stud [Fig 2.5(b)] to monitor the temperature of the battery electrolyte. The Sensor Head contains an embedded Negative Temperature Coefficient (NTC) Resistor with 2 internal terminals "NTC+" and "NTC -". Internal terminal "NTC+" is wired to Pin 4 of the RJ-45 Plug [2 in Fig 2.5(a)] and internal terminal "NTC -" is wired to Pin 5 of the RJ-45 Plug.

RJ-45 Plug [2 in Fig 2.5(a)]: The RJ-45 Plug is required to be plugged into the RJ-45 Jack marked "Battery Temp Sensor" on the front panel of EVO (6 in Fig 2.1). Pinout of this RJ-45 Jack is shown in Fig 5.0.

SECTION 5 | Battery Charging in Evolution™ Series

RJ-45 Jack on the Front Panel of EVO™ (6, Fig 2.1) for Connecting Battery Temperature Sensor

Pinout of this RJ-45 Jack [marked “Battery Temp Sensor” on the front panel of EVO (6 in Fig 2.1)] is shown at Fig 5.0 below (also shown at Fig 3.13):

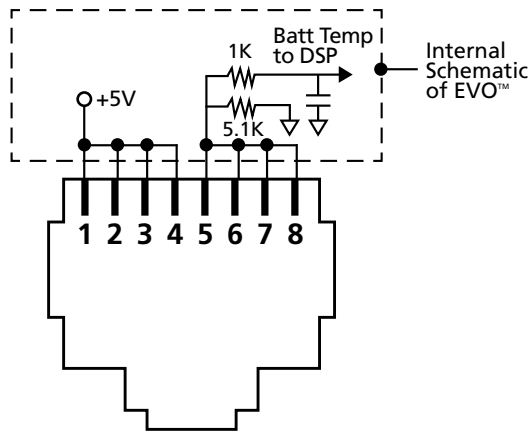

Fig 5.0 Pinout of RJ-45 Jack marked “Battery Temp Sensor” on the front panel of EVO (6 in Fig 2.1).

5.6 CHARGING PROFILES

Please refer to Section 1.4.3 regarding general information on 4 stages of battery charging. Depending upon the type of batteries to be charged and its application, 2/3/4 charging stages may be used based on the appropriate Charging Profile.

When AC input within the programmed window of voltage and frequency is available, EVO will operate as a battery charger. Option is available for 7 charging profiles as follows:

- 6 options for the following 3-Stage / 2-Stage charging profiles through programming parameter “CHARGING PROFILE” designed to cover various charging requirements for Lead Acid, Nickel-Zinc (Ni-Zn) and Lithium Ion Batteries.

- 0 = 3 Stage Adaptive (Default)
- 1 = 3 Stage Type 1
- 2 = 3 Stage Type 2
- 3 = 2 Stage Type 1
- 4 = 2 Stage Type 2
- 5 = 2 Stage Type 3

Refer to the following for more details:

- Section 5.7 for description and charging curves for 3-Stage Charging Profiles
- Section 5.10 for description and charging curves for 2-Stage Charging Profiles
- [Programming procedure at Section 4.4.2.21 in the EVO-RC-PLUS Remote Control Manual](#)

- 1 option for 4-Stage Adaptive Charging Profile for Equalization for Lead Acid Batteries

Refer to the following for more details:

- Section 5.8 for description and charging profiles
- [Programming procedure at Section 4.4.2.12 in the EVO-RC-PLUS Remote Control Manual](#)

SECTION 5 | Battery Charging in Evolution™ Series



CAUTION!

The Battery Management System (BMS) that comes with the type of Lithium Battery being used may need to have control over charging and discharging of the battery. For this, Pins 4 and 5 of the Temperature Sensor Jack (6, Fig 2.1; Pinout at Fig 5.0) may be used to feed potential free contact closing signal from the BMS to “Stop Charging” or “Stop Inverting” Refer to Section 5.11.2 for details.



ATTENTION!

Le système de gestion de la batterie (BMS) qui vient avec le type de batterie au lithium utilisé aura besoin d'avoir le contrôle de charge et décharge de la batterie. Pour cela, les broches 4 et 5 du capteur de température (6, Fig. 2.1; Pinout à la Fig. 5.0) peut être utilisé pour l'alimentation contact libre de signal de fermeture de la BMS à "arrêter la charge" ou "arrêter d'inverser". Se reporter à la Section 5.11.2 pour plus de détails.

5.7 3-STAGE CHARGING PROFILE - DETAILED EXPLANATION

Refer to 3 types of 3-Stage Charging Profile options at Srls. 1 to 3 in TABLE 5.2.

Fig. 5.1 shows the voltage and current charging curves with respect to time and different charging stages associated with these profiles.



INFO

4-Stage Adaptive Charging Profile for Equalization is also available and can be activated at any time during charging taking place under these 3-stage profiles. *Procedure to activate 4-Stage Adaptive Charging Profile for Equalization is described under programming parameter "EQUALIZE-4 STAGES" at Section 4.4.2.12 in the EVO-RC-PLUS Remote Control Manual.*

SECTION 5 | Battery Charging in Evolution™ Series

TABLE 5.2 3 TYPES OF CHARGING PROFILE OPTIONS FOR 3-STAGE CHARGING

Srl No.	Options under Programming Parameter "CHARGING PROFILE" <i>(See Section 4.4.2.21 in EVO-RC-PLUS Remote Control Manual)</i>	Charging Stages	Battery Type
1	0 = 3 Stage Adaptive NOTES: 1. This is the default, <u>3-Stage Adaptive Type of Charging Profile with Adaptive Time Algorithm for Absorption Stage</u>	<ol style="list-style-type: none"> Stage 1 – Bulk Stage <i>(See Section 5.7.1.1 for details)</i> <ul style="list-style-type: none"> Charge at constant current (CC) = the programmed value of parameter "BULK CURRENT" (Default value is 20A. <i>For details of programming range & procedure, refer to Section 4.4.2.1 of EVO-RC-PLUS Remote Control Manual</i>) Transition to Absorption Stage when voltage rises to the set value for programming parameter "ABSORP VOLTAGE" (Default value is 14.4V for EVO-1212F/1212F-HW and 28.8V for EVO-1224F/1224F-HW. <i>For details of programming range & procedure, refer to Section 4.4.2.2 of EVO-RC-PLUS Remote Control Manual</i>) Stage 2 - Absorption Stage <i>(See Section 5.7.2 for details)</i> <ul style="list-style-type: none"> Charge at constant voltage (CV) = the programmed value for parameter "ABSORP VOLTAGE". (Default value is 14.4V for EVO-1212F/1212F-HW and 28.8V for EVO-1224F/1224F-HW. <i>For details of programming range & procedure, refer to Section 4.4.2.2 of EVO-RC-PLUS Remote Control Manual</i>) Adaptive Time Algorithm: Time in Absorption Stage is computed automatically based on time in Bulk Stage <i>(See Section 5.7.2 for details)</i>. Transition to Float Stage thereafter. Stage 3 - Float Stage <i>(See Section 5.7.3 for details)</i> <ul style="list-style-type: none"> Charge at constant voltage (CV) = the programmed value of parameter "FLOAT VOLTAGE". (Default value is 13.5V for EVO-1212F/1212F-HW and 27.0V for EVO-1224F/1224F-HW. <i>For details of programming range & procedure, refer to Section 4.4.2.4 of EVO-RC-PLUS Remote Control Manual</i>) Reset to Bulk Stage under the following conditions: <ol style="list-style-type: none"> If the AC input is disconnected and is reconnected. If battery voltage falls to the programmed value of parameter "RESET TO BULK" (Default value is 12.0V for EVO-1212F/1212F-HW and 24.0V for EVO-1224F/1224F-HW. <i>For details of programming range & procedure, refer to Section 4.4.2.15 of EVO-RC-PLUS Remote Control Manual</i>) If the charger remains in the Float Stage for 10 days 	<ul style="list-style-type: none"> Lead Acid: Flooded and sealed – AGM/Gel Cell ENSURE that there are no other DC load(s) on the batteries. Load(s) on the battery may drain full or part of the charging current and will upset the "Adaptive Time Algorithm" for Absorption Stage time
2	1 = 3 Stage Type 1	<ol style="list-style-type: none"> Stage 1 – Bulk Stage <i>(See Section 5.7.1.1 for details)</i> <ul style="list-style-type: none"> Charge at constant current (CC) = the programmed value of parameter "BULK CURRENT" (Default value is 20A. <i>For details of programming range & procedure, refer to Section 4.4.2.1 of EVO-RC-PLUS Remote Control Manual</i>) Transition to Absorption Stage when voltage rises to the set value for programming parameter "ABSORP VOLTAGE" (Default value is 14.4V for EVO-1212F/1212F-HW and 28.8V for EVO-1224F/1224F-HW. <i>For details of programming range & procedure, refer to Section 4.4.2.2 of EVO-RC-PLUS Remote Control Manual</i>) Stage 2 - Absorption Stage <i>(See Section 5.7.2 for details)</i> <ul style="list-style-type: none"> Charge at constant voltage (CV) = the programmed value for parameter "ABSORP VOLTAGE". (Default value is 14.4V for EVO-1212F/1212F-HW and 28.8V for EVO-1224F/1224F-HW. <i>For details of programming range & procedure, refer to Section 4.4.2.2 of EVO-RC-PLUS Remote Control Manual</i>) Remain in Absorption Stage for time duration = programmed value of parameter "ABSORP TIME" (Default value is 60 min. <i>For details of programming range & procedure, refer to Section 4.4.2.19 of EVO-RC-PLUS Remote Control Manual</i>) Transition to Float Stage thereafter. 	<ul style="list-style-type: none"> Lead Acid: Flooded and sealed – AGM/Gel Cell Lithium <i>(See Section 5.11 for details)</i>

SECTION 5 | Battery Charging in Evolution™ Series

		<p>3. Stage 3 - Float Stage (See Section 5.7.3 for details)</p> <ul style="list-style-type: none"> Charge at constant voltage (CV) = the programmed value of parameter "FLOAT VOLTAGE". (Default value is 13.5V for EVO-1212F/1212F-HW and 27.0V for EVO-1224F/1224F-HW. For details of programming range & procedure, refer to Section 4.4.2.4 of EVO-RC-PLUS Remote Control Manual) Reset to Bulk Stage under the following conditions: <ul style="list-style-type: none"> i. If the AC input is disconnected and is reconnected. ii. If battery voltage falls to the programmed value of parameter "RESET TO BULK" (Default value is 12.0V for EVO-1212F/1212F-HW and 24.0V for EVO-1224F/1224F-HW. For details of programming range & procedure, refer to Section 4.4.2.15 of EVO-RC-PLUS Remote Control Manual). iii. If the charger remains in the Float Stage for 10 days 	
3	2 = 3 Stage Type 2	<p>1. Stage 1 – Bulk Stage (See Section 5.7.1.1 for details)</p> <ul style="list-style-type: none"> Charge at constant current (CC) = the programmed value of parameter "BULK CURRENT" (Default value is 20A. For details of programming range & procedure, refer to Section 4.4.2.1 of EVO-RC-PLUS Remote Control Manual) Transition to Absorption Stage when voltage rises to the set value for programming parameter "ABSORP VOLTAGE" (Default value is 14.4V for EVO-1212F/1212F-HW and 28.8V for EVO-1224F/1224F-HW. For details of programming range & procedure, refer to Section 4.4.2.2 of EVO-RC-PLUS Remote Control Manual) <p>2. Stage 2 - Absorption Stage (See Section 5.7.2 for details)</p> <ul style="list-style-type: none"> Charge at constant voltage (CV) = the programmed value for parameter "ABSORP VOLTAGE". (Default value is 14.4V for EVO-1212F/1212F-HW and 28.8V for EVO-1224F/1224F-HW. For details of programming range & procedure, refer to Section 4.4.2.2 of EVO-RC-PLUS Remote Control Manual) Remain in Absorption Stage till the current reduces to value = the programmed value of parameter "ABSORP EXIT AMPS" (Default value is 4A. For details of programming range & procedure, refer to Section 4.4.2.20 of EVO-RC-PLUS Remote Control Manual) Transition to Float Stage thereafter. <p>3. Stage 3 - Float Stage (See Section 5.7.3 for details)</p> <ul style="list-style-type: none"> Charge at constant voltage (CV) = the programmed value of parameter "FLOAT VOLTAGE". (Default value is 13.5V for EVO-1212F/1212F-HW and 27.0V for EVO-1224F/1224F-HW. For details of programming range & procedure, refer to Section 4.4.2.4 of EVO-RC-PLUS Remote Control Manual) Reset to Bulk Stage under the following conditions: <ul style="list-style-type: none"> i. If the AC input is disconnected and is reconnected. If battery voltage falls to the programmed value of parameter "RESET TO BULK" (Default value is 12.0V for EVO-1212F/1212F-HW and 24.0V for EVO-1224F/1224F-HW. For details of programming range & procedure, refer to Section 4.4.2.15 of EVO-RC-PLUS Remote Control Manual) <ul style="list-style-type: none"> ii. If the charger remains in the Float Stage for 10 days 	<ul style="list-style-type: none"> – Lead Acid: Flooded and sealed – AGM/Gel Cell – Lithium (See Section 5.11 for details)

5.7.1.1 STAGE 1 – Bulk Charge Stage

Refer to Fig 5.1 and Srl No. 1 of TABLE 5.2

During the 1st Bulk Charge Stage, the Duty Cycle of the boosted high frequency PWM voltage pulses (Section 5.1.2) is adjusted continuously to charge the battery at constant current (CC) = the programmed value of parameter "BULK CURRENT" designated as "Io" (Default value is 20A. For details of programming range & procedure for parameter "BULK CURRENT", refer to Section 4.4.2.1 of EVO-RC-PLUS Remote Control Manual)

NOTE: The current will slowly ramp up to the programmed value of "BULK CURRENT"

SECTION 5 | Battery Charging in Evolution™ Series

This current is delivered to the batteries until the battery voltage approaches its Gassing Voltage i.e. Absorption Voltage which is typically around 14.4 volts for 12 volt batteries and 28.8 volts for 24 volt batteries. The desired value can be programmed using the optional Remote Control EVO-RC-PLUS [Refer to parameter "ABSORP VOLTAGE" in Table 6.2 and at Section 4.4.2.2 of EVO-RC-PLUS manual]. The Bulk Charge Stage restores about 75% of the battery's charge. The Gassing Voltage is the voltage at which the electrolyte in the battery begins to break down into Hydrogen and Oxygen gases. Under normal circumstances, a battery should not be charged at a voltage above its Gassing Voltage since this will cause the battery to lose electrolyte and dry out over time.

This stage is displayed as "X-Bulk Stage" in the 2nd line of the Charging Mode screens in the Remote Control EVO-RC-PLUS. Refer to the display screens shown in Fig 3.3(a) under Section 3.6.4.1 of EVO-RC-PLUS Remote Control Manual. Character "X" denotes code for the Charging Profile that is active. (For details of codes, please see Table 3.2 under Section 3.6.4.3 of EVO-RC-PLUS Remote Control Manual).

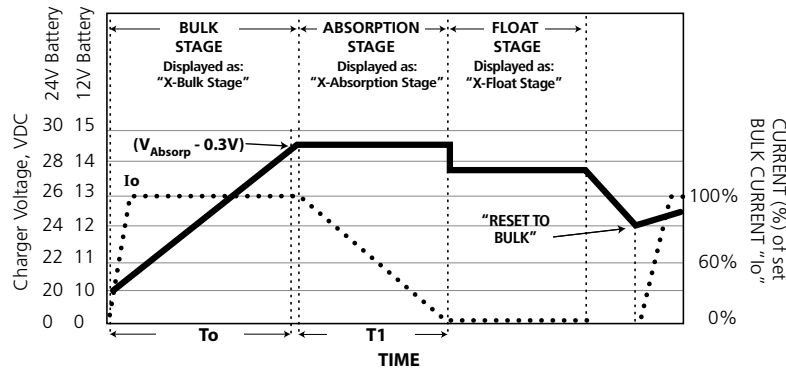

LEGEND for Fig 5.1	
	Voltage (V) Curve
	Current (I) Curve
I_o	Bulk Stage Current. <i>Please see Section 5.7.1.1</i>
T_o	Bulk Stage Time. <i>Please see Section 5.7.1.1</i>
T_1	Time in Absorption Stage. <i>Please see Section 5.7.2</i>
"X-BULK STAGE", "X-ABSORPTION STAGE", "X-FLOAT STAGE"	This coded information relates to the active Charging Profile and Charging Stage and is displayed in the 2 nd line of the Charging Mode Display Screens of EVO-RC-PLUS Remote Control. <i>Please see Table 3.2 under Section 3.6.4.3 of EVO-RC-PLUS Remote Control Manual</i>
RESET TO BULK	At this point, the charger is forced to reset automatically from the operating charging stage and restart the selected CHARGING PROFILE from the 1st Stage i.e. from the Bulk Stage. <i>Please see Section 5.7.4</i>

NOTES for Fig 5.1	
1.	Voltage (V) and Current (I) curves show the battery voltage and current.
2.	The Voltage (V) and Current (I) curves shown are based on the following operating conditions: <ul style="list-style-type: none"> a) The battery is being charged exclusively by the Battery charging Section of EVO and that there is NO external charging source that is charging the battery / battery bank b) There is no external DC load on the battery / battery bank (the entire current delivered by the Charging Section of EVO is being used to charge the battery / battery bank)

Fig 5.1 Charging Curves for 3-Stage Charging Profile

SECTION 5 | Battery Charging in Evolution™ Series

The value of the "BULK CURRENT" ("Io") depends upon the total Ampere Hour (Ah) capacity of the battery or bank of batteries. A battery should never be charged at very high charging current as very high rate of charging will not return the full 100 percent capacity as the Gassing Voltage rises with higher charging current. **As a general Rule of Thumb, the BULK CURRENT "Io" for Lead Acid Batteries should be limited to 10% to 20% of the Ah capacity of the battery [Ah capacity at C-rate of discharge = C/20 (or, 0.05C)].** Higher charging current may be used for Lead Acid Batteries if permitted by the battery manufacturer. Lithium Ion & Nickel Zinc batteries may be charged at higher rates of up to 50% to 100% of their Ah capacity.

Programming range and Default values of "BULK CURRENT" ("Io") are shown in Table 6.2 and also at Table 4.3 under Section 4.4.1 of EVO-RC-PLUS Remote Control Manual. The units are shipped with the "BULK CURRENT" set at the Default Value of 20A. For programming information for this parameter, please refer to Section 4.4.2.1 of EVO-RC-PLUS Remote Control Manual.

When the unit enters Charging Mode, it starts working as a battery charger and the charger will ramp up to full programmed "BULK CURRENT" until the charger reaches the programmed threshold of "ABSORP VOLTAGE".
NOTE: The charging current will slowly ramp up to the programmed value of BULK CURRENT.

For Adaptive Charging Profile Option "0=3 Stage Type 0" (See Srl. No. 1 in Table 5.2), a software timer will measure the time taken from the instant the unit enters the Bulk Charging Stage until the instant the battery voltage reaches 0.3V below the programmed "ABSORP VOLTAGE", then registers this time as Bulk Charge Time "To" and computes Absorption Time "T1" as 10 times the Bulk Charge Time "To" in the internal "T1 Timer" i.e. $T1 = To \times 10$ (Minimum value of "T1" is 1 Hr and max value is 12 Hrs). The "T1 Timer" is used to determine the time the charging will take place in the next Absorption Stage (Section 5.7.2).

5.7.1.2 Automatic Adjustments of Internal AC Charger Current When External Solar Charge Controller is Also Charging in Parallel

Please note that if an external Solar Charge Controller is also used to charge the batteries at the same time in parallel with the internal AC charger of the unit, the charging current of the internal AC charger will be controlled so that the total charging current of the external Solar Charge Controller and the internal charger is = the programmed "BULK CURRENT" ("Io").

For example, if the programmed "BULK CURRENT" ("Io") is say 40A and the charging current of the external Solar Charge Controller is 30A, the internal AC charger will output only 10A (Programmed setting of 40A – external charging current of 30A = 10A). Similarly, if the programmed setting is say 30A and the current supplied by the external Solar Charge Controller is say 50A, the internal AC charger will NOT provide any charging current.

Please refer to Section 5.4 for more details.

5.7.2 STAGE 2 – Absorption Stage

During the Absorption Stage, the Duty Cycle of the boosted high frequency PWM voltage pulses (Section 5.1.2) is adjusted continuously to keep the battery at constant voltage (CV) = the programmed value of parameter "ABSORP VOLTAGE" to ensure that the battery is further charged to the full capacity without overcharging. Programming range and Default values of "ABSORP VOLTAGE" are shown in Table 6.2. Default value is 14.4V for EVO-1212F / EVO-1212F-HW and 28.8V for EVO-1224F / EVO-1224F-HW. For programming details of parameter "ABSORP VOLTAGE", refer to Section 4.4.2.2 of the EVO-RC-PLUS manual. The Absorption Stage restores the remaining 25% of the battery's charge. The time the charger remains in the Absorption Stage is proportional to the depth of discharge of the battery. When the battery is more discharged, it will take longer time in the Bulk Charge Stage to reach the Gassing / Absorption Voltage.

SECTION 5 | Battery Charging in Evolution™ Series

For 3-Stage Adaptive Charging Profile Option "0=3 Stage Adaptive" (See Srl. No. 1 in Table 5.2), T1 Timer (explained under Bulk Stage in Section 5.7.1.1 and Fig 5.1) computes the time of charging in this stage as follows:

- Absorption Time "T1" = Bulk Charge Time "To" x 10 ("To" = Time from entering Bulk Charge Stage till battery voltage rises to 0.3V below Absorption Voltage).
- The "T1 Timer" has minimum time of 1 hour and a maximum time of 12 hours.
- When the "T1 Timer" runs out, the charger will enter the next Float Stage.
- Programming range and Default values of Absorption Voltage are shown in Table 6.2.

For the other 3-Stage Charging Profiles, "Stage 2 - Absorption Stage" is controlled as follows:

- Option "1 = 3 Stage Type 1" (See Srl. 2 of Table 5.2)
- Option "2 = 3 Stage Type 2" (See Srl. 3 of Table 5.2)

This stage is displayed as "X-Absorption Stage" in the 2nd line of the Charging Mode screens in the Remote Control EVO-RC-PLUS. *[Refer to the screen Nos. 1 to 5 shown in Fig 3.3(a) under Section 3.6.4.1 of EVO-RC-PLUS Remote Control Manual. Character "x" denotes code for the Charging Profile that is active. For details of codes for the Charging Profiles, please see Table 3.2 under Section 3.6.4.3 of Owner's Manual for EVO-RC-PLUS]*

5.7.3 STAGE 3 – Float Stage

Float Stage is a maintenance stage in which the Duty Cycle of the boosted high frequency PWM voltage pulses (Section 5.1.2) is adjusted continuously to keep the battery voltage at level = the programmed parameter "FLOAT VOLTAGE", typically about 13.5V for 12V models and 27.0V for 24V models to maintain the battery's charge without losing electrolyte through gassing and also, prevent corrosion of Positive plate by maintaining proper Positive Plate Polarization Voltage. Programmable range of values of "FLOAT VOLTAGE" are shown in Table 6.2. Default value is 13.5V for EVO-1212F / EVO-1212F-HW and 27.0V for EVO-1224F / EVO-1224F-HW. *For programming of parameter "FLOAT VOLTAGE", refer to Section 4.4.2.4 of EVO-RC-PLUS Remote Control Manual.*

This stage is displayed as "X-FLOAT STAGE" in the 2nd line of the Charging Mode screens in the Remote Control EVO-RC-PLUS *[Refer to the screen Nos. 1 to 5 shown in Fig 3.3(a) under Section 3.6.4.1 of EVO-RC-PLUS Remote Control Manual. Character "x" denotes code for the Charging Profile that is active. For details of codes for the Charging Profiles, please see Table 3.2 under Section 3.6.4.3 of Owner's Manual for EVO-RC-PLUS]*

5.7.4 Automatic Resetting of Charging Cycle

The charging cycle will be reset to the Bulk Stage *[Section 5.8.2.1]* as follows:

- a) If the AC input is disconnected and is reconnected
- b) If battery discharges and its voltage falls to the voltage level set by programming parameter "RESET TO BULK" *[For details, refer to Section 4.4.2.15 of EVO-RC-PLUS Remote Control Manual]*. Programming range for this parameter is:
 - i. 10 to 13VDC for EVO-1212F / EVO-1212F-HW (Default value is 12.0VDC)
 - ii. 20 to 26VDC for EVO-1224F / EVO-1224F-HW (Default value is 24.0VDC)
- c) If the charger remains in the Float Stage for 10 days

SECTION 5 | Battery Charging in Evolution™ Series

5.8 4 STAGE ADAPTIVE CHARGING PROFILE - EQUALIZATION



CAUTION!

4-Stage Adaptive Charging Profile - Equalization should be used only for vented, flooded (non-sealed or "wet") batteries and not on sealed AGM / Gel Cell / Nickel-Zinc (Ni-Zn) / Lithium batteries and only as often as recommended by the battery manufacturer.



ATTENTION!

Profil de charge adaptative en 4 étapes - L'égalisation ne doit être utilisée que sur des batteries ventilées (non scellées ou «humides») et non sur des batteries scellées AGM / Gel / Nickel-Zinc (Ni-Zn) / Lithium et seulement aussi souvent que recommandé par le fabricant de batteries.

5.8.1 Brief Description:

4-Stage Adaptive Charging Profile for Equalization is used to equalize Flooded / Wet Cell Lead Acid Batteries. Equalization is carried out periodically – normally once per month for battery under heavy duty service and every 2 to 4 months for battery under light duty service. During the Equalization Stage, the battery is intentionally over-charged / boiled for a specified time period to equalize voltage of individual cells. Other benefits include reduction in sulfation and stirring up of the electrolyte to remove stratification. This results in maintaining the peak capacity of the battery.



INFO

Please read Section 1.4.4 regarding more details on necessity of equalizing batteries.

This 4-Stage Adaptive Charging Profile can be activated as follows:

- Using optional Remote Control Model EVO-RC-PLUS. Programming Parameter "EQUALIZE-4STAGES" is required to be set at "1=Yes". *Refer to Section 4.4.2.12 of EVO-RC-PLUS Manual.*
- If Remote Control EVO-RC-PLUS is not available, by pressing On/Off Push Button on the front panel of the EVO (11, Fig 2.1) for 1 sec. The cycle can be stopped prematurely by pressing the On/Off Push Button for 1 sec. Please refer to Section 5.9 for more details.

5.8.2 4-Stage Adaptive Charging Profile for Equalization – Charging Curves

Fig 5.2 shows the voltage and current curves during the 4 stages under this profile. Details are explained below:

As part of this **Adaptive Equalization Algorithm**, the charging process in the Equalization Stage is based on time "**To**" which is the time the charger remains in the initial Constant Current Bulk Charging Stage. In the Bulk Charging Stage, charging takes place at constant current (referred to as "CC" at programmed value of parameter "BULK CURRENT" *[See Section 4.4.2.1 of EVO-RC-PLUS Remote Control Manual]*). The charger will remain in the initial Bulk Charging Stage for a longer duration when the battery is deeply discharged and for a shorter duration if the battery has a shallow discharge.

SECTION 5 | Battery Charging in Evolution™ Series

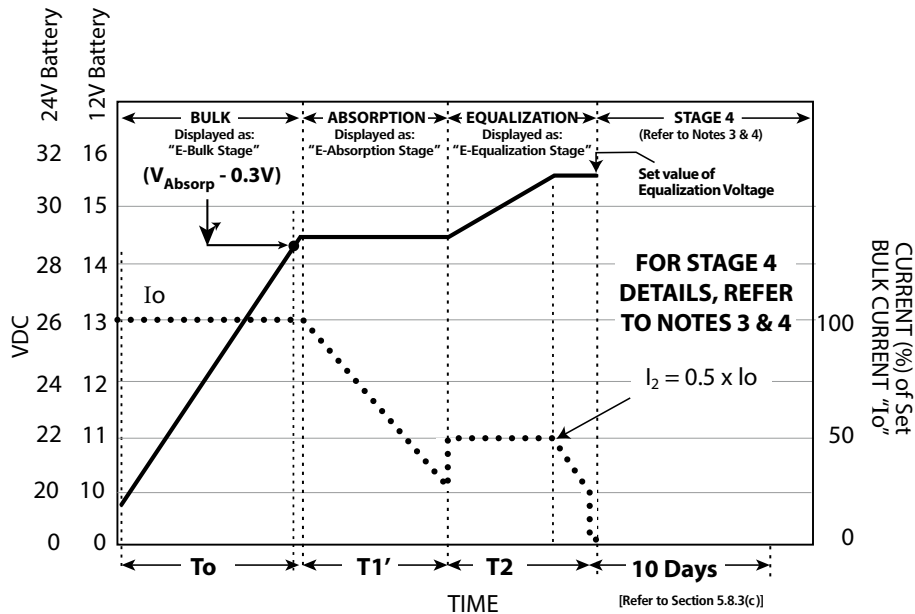

LEGEND for Fig 5.2	
	Voltage (V) Curve
	Current (I) Curve
I_o	Bulk Stage Current. <i>Please see Section 5.7.1.1</i>
T_o	Bulk Stage Time. <i>Please see Section 5.7.1.1</i>
$T1'$	Adaptive Time in Absorption Stage. <i>Refer to Section 5.8.2.1.2(a)</i>
$T2$	Adaptive Time in Equalization Stage. <i>Refer to Section 5.8.2.1.2(b)</i>
"E-Bulk Stage", "E-Absorption Stage", "E-Equalization Stage"	This coded information relates to the active Charging Profile and Charging Stage and is displayed in the 2 nd line of the Charging Mode Display Screens of EVO-RC-PLUS Remote Control. <i>Please see Table 3.2 under Section 3.6.4.3 of EVO-RC-PLUS Remote Control</i>

NOTES for Fig 5.2	
1.	Voltage (V) and Current (I) curves show the battery voltage and current.
2.	Voltage (V) and Current (I) curves shown are based on the following operating conditions: <ul style="list-style-type: none"> a) The battery is being charged exclusively by the Battery charging Section of EVO and that there is NO external charging source that is charging the battery / battery bank b) There is no external DC load on the battery / battery bank (the entire current delivered by the Charging Section of EVO is being used to charge the battery / battery bank)
3.	The 4 th Stage will be the same as the last stage of the parameter CHARGING PROFILE [See Section 4.4.2.21 in the EVO-RC-PLUS Remote Control Manual] from where Equalization was started. See Section 5.8.2.4 for details.
4.	See Section 5.8.3 regarding conditions under which the charger will be forced to reset automatically and restart charging in the 1 st Stage i.e. from the Bulk Stage of the programmed parameter CHARGING PROFILE [See Section 4.4.2.21 in the EVO-RC-PLUS Remote Control Manual]

Fig 5.2 Charging Curves for 4-Stage Adaptive Charging Profile for Equalization

SECTION 5 | Battery Charging in Evolution™ Series

5.8.2.1 Stage 1 – Bulk Charge Stage

Refer to Section 1.4.3.1 for general information on Bulk Charge Stage and to Fig 5.2 for voltage and current curves during this stage.

5.8.2.1.1 During the 1st “Bulk Charge Stage”, the batteries will be charged at constant current (CC) = the programmed value of parameter “BULK CURRENT” (“Io”) [Default value of Parameter “BULK CURRENT” is 20A. See programming range at Table 6.2 and programming procedure at Section 4.4.2.1 in the EVO-RC-PLUS Remote Control Manual]. The value of programmed parameter “BULK CURRENT” (“Io”) should normally be limited to 10% to 20% of the Ah capacity of the battery [Ah capacity at C-rate of discharge = C/20 (or, 0.05C)]. Higher current may be used if permitted by the battery manufacturer. The Bulk Charge Stage is displayed as “E-Bulk Stage” in the 2nd line of Charging Mode Screens of EVO-RC-PLUS Remote Control. [Please refer to codes / abbreviations in Table 3.2 under Section 3.6.4.3 of EVO-RC-PLUS Remote Control Manual].

5.8.2.1.2 A Software Timer is used to measure the time taken from the time the unit enters Bulk Stage to the time the battery voltage reaches 0.3V below the programmed value of parameter “ABSORP VOLTAGE” [Default value of parameter “ABSORP VOLTAGE” is 14.4V for EVO-1212F/1212F-HW and 28.8V for EVO-1224F/1224F-HW. See programming range at Table 6.2, Section 6 and programming procedure at Section 4.4.2.2 in the EVO-RC-PLUS Remote Control Manual]. This time is registered as Bulk Stage Time “To”. **As part of Adaptive Algorithm, the following times are computed based on the Bulk Stage Time “To”:**

- a) **Absorption Stage Time T1'** = To x 0.5
- b) **Equalization Stage Time T2:**
 - i. $T2 = T1' + 1 \text{ Hr} = (\text{To} \times 0.5) + 1 \text{ Hr}$; if T1' is <2 Hrs
 - ii. $T2 = T1' + 2 \text{ Hrs} = (\text{To} \times 0.5) + 2 \text{ Hr}$; if T1' is > 2 Hrs but <4 Hrs
 - iii. $T2 = T1' + 4 \text{ Hrs} = (\text{To} \times 0.5) + 4 \text{ Hr}$; if T1' is > 4 Hrs

5.8.2.1.3 When the battery voltage rises to the programmed value of parameter “ABSORP VOLTAGE”, the charging stage transitions to the next Stage 2 – Absorption Stage described at Section 5.8.2.2 below [Default value of parameter “ABSORP VOLTAGE” is 14.4V for EVO-1212F/1212F-HW and 28.8V for EVO-1224F/1224F-HW. See programming range at Table 6.2, Section 6 and programming procedure at Section 4.4.2.2 in the EVO-RC-PLUS Remote Control Manual].

5.8.2.1.4 Automatic Adjustment of Internal AC Charger Current when External Solar Charge Controller is also Charging in Parallel: Please note that if an external solar charge controller is also used to charge the batteries at the same time in parallel with the internal AC charger of the unit, the charging current of the internal AC charger will be controlled so that the total charging current of the external charger and the internal charger is = the programmed “BULK CURRENT (“Io”)” [See Section 4.4.2.1 of EVO-RC-PLUS Remote Control Manual].

For example, if the programmed value of parameter “BULK CURRENT” (“Io”) is say 40A and the charging current from the external Solar Charge Controller is say 30A at any given instant, the internal AC charger will output only 10A (Programmed value of 40A minus external charging current of 30A = 10A). Now, if the charging current from the External Charge Controller rises to say 50A, the internal AC charger will be reduced to 0A.

5.8.2.2 Stage 2 – Adaptive Absorption Stage

Refer Section 1.4.3.2 for general information on Absorption Stage and to Fig 5.2 for voltage and current curves during this stage.

SECTION 5 | Battery Charging in Evolution™ Series

5.8.2.2.1 During the 2nd “Absorption Stage”, the batteries will be charged at constant voltage (CV) = the programmed value of parameter “ABSORP VOLTAGE” [*Default value of parameter “ABSORP VOLTAGE” is 14.4V for EVO-1212F/1212F-HW and 28.8V for EVO-1224F/1224F-HW. See programming range at Table 6.2, Section 6 and programming procedure at Section 4.4.2.2 in the EVO-RC-PLUS Remote Control Manual*]. The Absorption Stage is displayed as “E-Absorption Stage” in the 2nd line of Charging Mode Screens of EVO-RC-PLUS Remote Control. [*Please refer to codes / abbreviations detailed at Table 3.2 under Section 3.6.4.3 of EVO-RC-PLUS Remote Control Manual*]. The charger remains in this stage for computed Time **T1'** [Refer to Section 5.8.2.1.2(a)] and then transitions to Stage 3 – Equalization Stage described at Section 5.8.2.3 below

5.8.2.3 Stage 3 –Adaptive Equalization Stage:

Refer Section 1.4.3.4 for general information on Equalization Stage and to Fig 5.2 for voltage and current curves during this stage

In this stage, charging takes place at constant voltage at value = the programmed value of parameter “EQUALIZE VOLTAGE” [*Default value is 14.40V for EVO-1212F/1212F-HW and 28.8V for EVO-1224F/1224F-HW. Please see programming range at Table 6.2 and programming procedure at Section 4.4.2.3 in EVO-RC-PLUS Remote Control Manual*]. It remains in this stage for computed time “T2” [Refer to Section 5.8.2.1.2(b)] and then transitions to Stage 4 described at Section 5.8.2.4 below

5.8.2.4 Stage 4 – Last Stage of 4-Stage Charging Profile for Equalization:

Stage 4 of the 4-Stage Charging Profile for Equalization will be the same as the last stage of the charging profile that was active when the 4-Stage Charging Profile for Equalization was switched on. See details at Table 5.2.1 below:

Table 5.2.1 Stage 4 of 4-Stage Adaptive Charging Profile for Equalization		
Charging Profile that was active when Equalization was started	Last Stage of Charging Profile at Column (1) from where Equalization was started	EVO-RC display at 1st line, right corner (See Note 1)
(1)	(2)	(3)
0=3 Stage Adaptive	FLOAT: Charge at constant voltage = “FLOATING VOLTAGE” • Exit to BULK STAGE when: o Voltage drops to “RESET TO BULK”, or o After 10 days in Float Stage	0 - Float Stage
1=3 Stage Type 1		1 - Float Stage
2= 3 Stage Type 2		2 - Float Stage
3= 2 Stage Type 1	OFF	3 - Charger Off
4= 2 Stage Type 2	Absorption Stage	4 - Absorption Stage
5= 2 Stage Type 3	Off	5 - Charger Off
NOTE 1:		
This portion of display is shown in the 2 nd line of Charging Mode display screens [<i>Refer to scrollable screens 1 to 5 of Menu Map for Charging Mode Screens at Fig 3.3(a) under Section 3.6.4.1 of EVO-RC-PLUS Remote Control Manual</i>].		

SECTION 5 | Battery Charging in Evolution™ Series

EXAMPLE BASED ON TABLE 5.2.1

Assume that 4-Stage Charging Profile for Equalization was switched on when 3-Stage Adaptive Charging Profile option "0= 3 Stage Type 0" was active [Column (1), Table 5.2.1]. In this Charging Profile, the last i.e. the 3rd Stage is FLOAT [Column (2), Table 5.2.1]. After completing the 3rd Stage of Equalization, the 4th Stage will, therefore, be FLOAT [Column (3), Table 5.2.1]. The 2nd line display "0-Float Stage" [Column (3), Table 5.2.1] indicates:

- "0" for the parameter CHARGING PROFILE set at Option "0=3 Stage Type 0"
- "Float Stage" indicates the last FLOAT Stage of 3-Stage Adaptive CHARGING PROFILE Option "0=3 Stage Type 0"

5.8.3 Automatic Resetting of 4-Stage Adaptive Charging Profile

The 4-Stage Adaptive Charging Profile explained at Section 5.8.2 above will be reset to the First Stage i.e. the Bulk Stage [[Section 5.8.2.1](#)] as follows:

- a) If the AC input fails and is restored or, it is disconnected and is reconnected
- b) If battery discharges and its voltage falls to the voltage level set by programming parameter "RESET TO BULK" [[For details, refer to Section 4.4.2.15 of EVO-RC-PLUS Remote Control Manual](#)].
Programming range for this parameter is:
 - i. 10 to 13VDC for EVO-1212F / EVO-1212F-HW (Default value is 12.0VDC)
 - ii. 20 to 26VDC for EVO-1224F / EVO-1224F-HW (Default value is 24.0VDC)
- c) If the charger remains in the Float Stage for 10 days

5.9 SWITCHING ON AND SWITCHING OFF PROCEDURE FOR 4-STAGE ADAPTIVE CHARGING PROFILE FOR EQUALIZATION

The default charging profile is "3-Stage Type 0" i.e. 3-Stage Adaptive [[Refer to \(i\) Srl. No 1, Table 5.2 and \(ii\) Section 4.4.2.21 in the EVO-RC-PLUS Remote Control Manual](#)]. 4-Stage Adaptive Charging Profile for Equalization is required to be activated manually as follows:

- **Initiating 4-Stage Adaptive Charging Profile for Equalization using ON/OFF Push Button (11, Fig 2.1) on the Front Panel (only if the Remote Control EVO-RC-PLUS is not connected to the EVO Inverter Charger or, is not available):** When the unit is in Charging Mode (qualified AC Input is available), the Blue LED marked "ON" (12, Fig 2.1) will be blinking once in 1 sec interval. Press the ON/OFF Button (11, Fig 2.1) for 1 second. The ongoing Charge Profile will be terminated and Adaptive Equalization will be initiated. The Blue LED marked "ON" (12, Fig 2.1) will start blinking twice in 1 sec interval to show that the 4-Stage Adaptive Charging Profile for Equalization is active. The unit will complete Equalization and terminate in the last stage of the charging profile that was active at the time the Equalization Profile was activated (Section 5.8.2.4). Henceforth, charging will continue in the initial charging profile that was active before equalization was initiated. At the same time, the Charging Profile Setting will again be reset to the original and the Blue LED marked "ON" (12, Fig 2.1) will return to 1 blink in 1 sec interval. **To terminate Equalization Profile prematurely before its completion, press the ON/OFF Push Button for 1 second.**

SECTION 5 | Battery Charging in Evolution™ Series

If the unit was in Inverting Mode [*Blue LED marked "ON" (12, Fig 2.1) steady*] and the Charging Profile is set to 4-Stage Adaptive Charging Profile for Equalization as above by pressing the ON/OFF Push Button for 1 second, the unit will initiate Equalization Profile whenever qualified AC input is available. To terminate Equalization Profile prematurely before its completion, press the ON/OFF Push Button for 1 second.

NOTE: Procedure described above is to be used when the optional Remote Control EVO-RC-PLUS has NOT been plugged into the RJ-45 Remote Control Jack (7, Fig 2.1). **Please note if the Remote Control has been plugged into the RJ-45 Jack, the above procedure cannot be activated and the ON/OFF of Equalization Profile will be controlled by the Remote Control EVO-RC-PLUS.**

5.10 2-STAGE CHARGING PROFILES

2-Stage Charging Profile may be used for charging Lead Acid, Lithium Ion and Nickel-Zinc (Ni-Zn) types of batteries.

In 2-Stage Charging Profile, the battery is charged in Bulk Stage first and then in Absorption Stage or Float Stage. There is no 3rd Stage.



INFO

The 2nd Stage i.e. Absorption Stage may also be referred to as Float Stage in some applications like charging Lead Acid Battery with load (battery backup application like in Telecom battery charging, Emergency Lighting etc.). In this application, the voltage setting of the 2nd Absorption Stage is lowered to the level corresponding to the Float Stage. Please note that under this condition, the battery will not charge fully but only to around 80%.

The following 3 programming options are available for 2-Stage Charging:

- 1) Option 3 = 2 Stage Type 1: Please refer to Srl. 1 of Table 5.3 for detailed description and Fig 5.3 for Voltage - Current (V-I) Curves
- 2) Option 4 = 2 Stage Type 2: Please refer to Srl. 2 of Table 5.3 for detailed description and Fig 5.4 for Voltage - Current (V-I) Curves
- 3) Option 5 = 2 Stage Type 3: Please refer to Srl. 3 of Table 5.3 for detailed description and Fig 5.5 for Voltage - Current (V-I) Curves



INFO

Please refer to Section 5.11 for more details regarding protections available in EVO Series when using 2-Stage Charging Profiles for charging Lithium Ion Battery Packs in association with their Battery Management System (BMS).

SECTION 5 | Battery Charging in Evolution™ Series

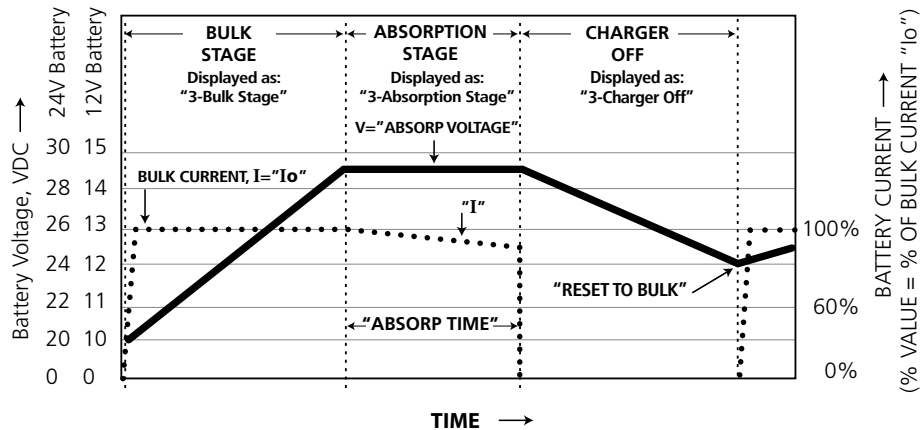

LEGEND for Fig 5.3

	Voltage (V) Curve
	Current (I) Curve
I_o	Bulk Stage Current. <i>Please see Section 5.7.1.1</i>
"3-Bulk Stage", "3-Absorption Stage", "3-Charger Off"	This coded information relates to the active Charging Profile and Charging Stage and is displayed in the 2 nd line of the Charging Mode Display Screens of EVO-RC-PLUS Remote Control. <i>Please see Table 3.2 under Section 3.6.4.3 of EVO-RC-PLUS Remote Control Manual</i>

NOTES for Fig 5.3

- Please see Srl. 1 of Table 5.3 for details of charging process*
- Voltage (V) and Current (I) curves show the battery voltage and current.
- The Voltage (V) and Current (I) curves shown are based on the following operating conditions:
 - The battery is being charged exclusively by the Battery charging Section of EVO and that there is NO external charging source that is charging the battery / battery bank
 - There is no external DC load on the battery / battery bank (the entire current delivered by the Charging Section of EVO is being used to charge the battery / battery bank)

Fig 5.3 Voltage – Current (V-I) Curves for "2-Stage Type 1" Charging Profile

SECTION 5 | Battery Charging in Evolution™ Series

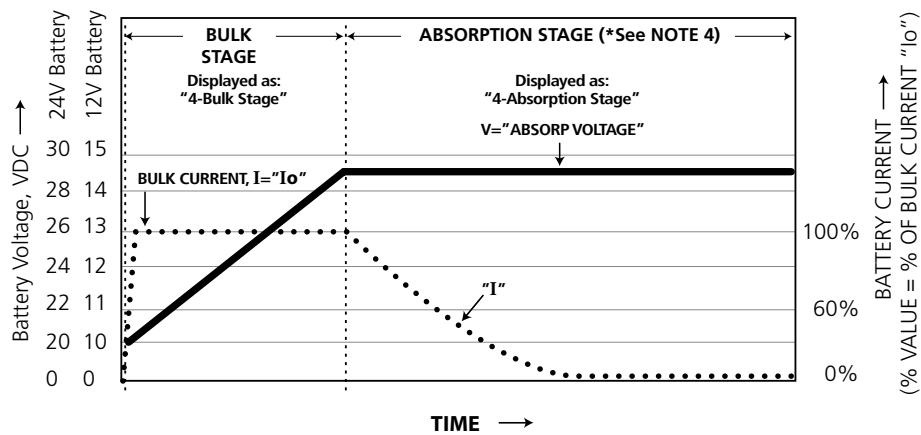

LEGEND for Fig 5.4	
	Voltage (V) Curve
	Current (I) Curve
I_o	Bulk Stage Current. <i>Please see Section 5.7.1.1</i>
"4-Bulk Stage", "4-Absorption Stage"	This coded information relates to the active Charging Profile and Charging Stage and is displayed in the 2 nd line of the Charging Mode Display Screens of EVO-RC-PLUS Remote Control. <i>Please see Table 3.2 under Section 3.6.4.3 of EVO-RC-PLUS Remote Control Manual</i>

NOTES for Fig 5.4	
1.	<i>Please see Srl. 1 of Table 5.3 for details of charging process</i>
2.	Voltage (V) and Current (I) curves show the battery voltage and current.
3.	The Voltage (V) and Current (I) curves shown are based on the following operating conditions: <ul style="list-style-type: none"> a) The battery is being charged exclusively by the Battery charging Section of EVO and that there is NO external charging source that is charging the battery / battery bank b) There is no external DC load on the battery / battery bank (the entire current delivered by the Charging Section of EVO is being used to charge the battery / battery bank)
4.	<i>Please see Section 5.7.4 regarding conditions under which the charger will be forced to reset automatically and restart charging from the 1st Stage i.e. Bulk Stage of the programmed CHARGING PROFILE</i>

Fig 5.4 Voltage – Current (V-I) Curves for "2-Stage Type 2" Charging Profile

SECTION 5 | Battery Charging in Evolution™ Series

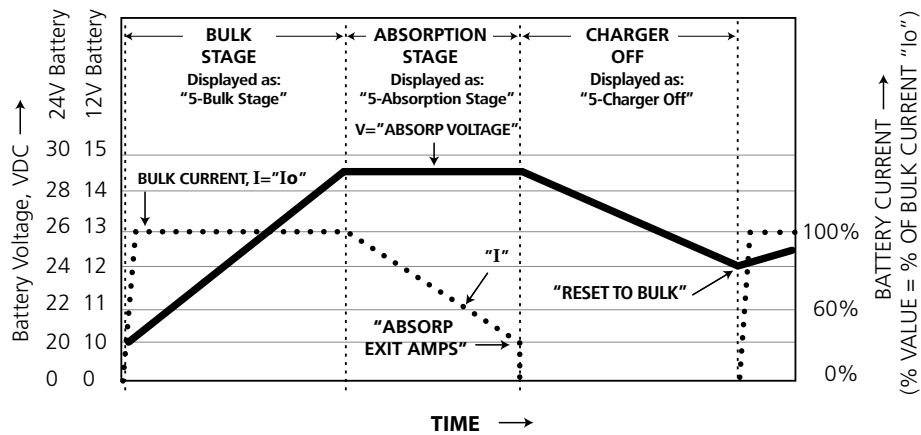

LEGEND for Fig 5.5	
	Voltage (V) Curve
	Current (I) Curve
I_o	Bulk Stage Current. <i>Please see Section 5.7.1.1</i>
"5-Bulk Stage", "5-Absorption Stage", "5-Charger Off"	This coded information relates to the active Charging Profile and Charging Stage and is displayed in the 2 nd line of the Charging Mode Display Screens of EVO-RC-PLUS Remote Control. <i>Please see Table 3.2 under Section 3.6.4.3 of EVO-RC-PLUS Remote Control Manual</i>
RESET TO BULK	At this point, the charger is forced to reset automatically from the operating charging stage and restart the selected CHARGING PROFILE from the 1 st Stage i.e. from the Bulk Stage. <i>Please see Section 5.7.4</i>
ABSORP EXIT AMPS	When charging current in Absorption Stage drops to value set by programming parameter "ABSORP EXIT AMPS", the charger is switched off <i>[The default value of parameter "ABSORP EXIT AMPS" is 4A. For details of programming range or programming procedure, refer to Section 4.4.2.20 of the EVO-RC-PLUS Remote Control Manual]</i>

NOTES for Fig 5.5	
1.	<i>Please see Srl. 3 of Table 5.3 for details of charging process</i>
2.	Voltage (V) and Current (I) curves show the battery voltage and current.
3.	The Voltage (V) and Current (I) curves shown are based on the following operating conditions: <ol style="list-style-type: none"> The battery is being charged exclusively by the Battery charging Section of EVO and that there is NO external charging source that is charging the battery / battery bank There is no external DC load on the battery / battery bank (the entire current delivered by the Charging Section of EVO is being used to charge the battery / battery bank)

Fig 5.5 Voltage – Current (V-I) Curves for "2-Stage Type 3" Charging Profile

SECTION 5 | Battery Charging in Evolution™ Series

TABLE 5.3 3 TYPES OF CHARGING PROFILE OPTIONS FOR 2-STAGE CHARGING

Srl No.	Options under Programming Parameter "CHARGING PROFILE" <i>(See Section 4.4.2.21 in EVO-RC-PLUS Remote Control Manual)</i>	Charging Stages	Battery Type
1	3=2Stage Type1 <u>REFER TO FIG 5.3 FOR VOLTAGE-CURRENT (V-I) CURVES</u>	<p>1. Stage 1 – Bulk Stage (See Section 5.7.1.1)</p> <ul style="list-style-type: none"> Charge at constant current = the programmed value of parameter "BULK CURRENT" (Default value is 20A. <i>For details of programming range & procedure, refer to Section 4.4.2.1 of EVO-RC-PLUS Remote Control Manual</i>) Transition to Absorption Stage when voltage rises to the set value for programming parameter "ABSORP VOLTAGE" (Default value is 14.4V for EVO-1212F/1212F-HW and 28.8V for EVO-1224F/1224F-HW. <i>For details of programming range & procedure, refer to Section 4.4.2.2 of EVO-RC-PLUS Remote Control Manual</i>) <p>2. Stage 2 - Absorption Stage (See Section 5.7.2)</p> <ul style="list-style-type: none"> Charge at constant voltage = the programmed value for parameter "ABSORP VOLTAGE". (Default value is 14.4V for EVO-1212F/1212F-HW and 28.8V for EVO-1224F/1224F-HW. <i>For details of programming range & procedure, refer to Section 4.4.2.2 of EVO-RC-PLUS Remote Control Manual</i>). Remain in Absorption Stage till the time in Absorption Stage is = the programmed value of parameter "ABSORP TIME" (Default value is 60 min. <i>For details of programming range & procedure, refer to Section 4.4.2.19 of EVO-RC-PLUS Remote Control Manual</i>). Switch off charging after expiry of programmed value of parameter "ABSORP TIME" (Default value is 60 min. <i>For details of programming range & procedure, refer to Section 4.4.2.19 of EVO-RC-PLUS Remote Control Manual</i>). Reset to Bulk Stage under the following conditions: <ol style="list-style-type: none"> If the AC input is disconnected and is reconnected. If battery voltage falls to the programmed value of parameter "RESET TO BULK" (Default value is 12.0V for EVO-1212F/1212F-HW & 24.0V for EVO-1224F/1224F-HW. <i>For details of programming range & procedure, refer to Section 4.4.2.15 of EVO-RC-PLUS Remote Control Manual</i>). 	<ul style="list-style-type: none"> Lithium (<i>See Section 5.11</i>) Nickel Zinc (<i>See Section 5.10</i>)

SECTION 5 | Battery Charging in Evolution™ Series

<p>2</p> <p>4=2Stage Type2</p> <p><u>REFER TO FIG 5.4 FOR VOLTAGE-CURRENT (V-I) CURVES</u></p>	<p>1. Stage 1 – Bulk Stage (See Section 5.7.1.1)</p> <ul style="list-style-type: none"> Charge at constant current = the programmed value of parameter “BULK CURRENT” (Default value is 20A. For details of programming range & procedure, refer to Section 4.4.2.1 of EVO-RC-PLUS Remote Control Manual) Transition to Absorption Stage when voltage rises to the set value for programming parameter “ABSORP VOLTAGE” (Default value is 14.4V for EVO-1212F/1212F-HW and 28.8V for EVO-1224F/1224F-HW. For details of programming range & procedure, refer to Section 4.4.2.2 of EVO-RC-PLUS Remote Control Manual) <p>2. Stage 2 - Absorption Stage (See Section 5.7.2)</p> <ul style="list-style-type: none"> Charge at constant voltage (CV) = the programmed value for parameter “ABSORP VOLTAGE”. (Default value is 14.4V for EVO-1212F/1212F-HW and 28.8V for EVO-1224F/1224F-HW. For details of programming range & procedure, refer to Section 4.4.2.2 of EVO-RC-PLUS Remote Control Manual) Remain in Absorption Stage Reset to Bulk Stage under the following conditions: <ul style="list-style-type: none"> i. If the AC input from the Grid/Generator is disconnected and is reconnected. ii. If battery voltage falls to the programmed value of parameter “RESET TO BULK” (Default value is 12.0V for EVO-1212F/1212F-HW and 24.0V for EVO-1224F/1224F-HW. For details of programming range & procedure, refer to Section 4.4.2.15 of EVO-RC-PLUS Remote Control Manual). 	<p>– Lithium (See Section 5.11)</p>
<p>3</p> <p>5=2Stage Type3</p> <p><u>REFER TO FIG 5.5 FOR VOLTAGE-CURRENT (V-I) CURVES</u></p>	<p>1. Stage 1 – Bulk Stage (See Section 5.7.1.1)</p> <ul style="list-style-type: none"> Charge at constant current = the programmed value of parameter “BULK CURRENT” (Default value is 20A. For details of programming range & procedure, refer to Section 4.4.2.1 of EVO-RC-PLUS Remote Control Manual) Transition to Absorption Stage when voltage rises to the set value for programming parameter “ABSORP VOLTAGE” (Default value is 14.4V for EVO-1212F/1212F-HW and 28.8V for EVO-1224F/1224F-HW. For details of programming range & procedure, refer to Section 4.4.2.2 of EVO-RC-PLUS Remote Control Manual) <p>2. Stage 2 - Absorption Stage (See Section 5.7.2)</p> <ul style="list-style-type: none"> Charge at constant voltage = the programmed value for parameter “ABSORP VOLTAGE”. (Default value is 14.4V for EVO-1212F/1212F-HW and 28.8V for EVO-1224F/1224F-HW. For details of programming range & procedure, refer to Section 4.4.2.2 of EVO-RC-PLUS Remote Control Manual) Remain in Absorption Stage till the current reduces to value = the programmed value of parameter “ABSORP EXIT AMPS” (Default value is 4A. For details of programming range & procedure, refer to Section 4.4.2.20 of EVO-RC-PLUS Remote Control Manual) Switch off charging after the current reduces to value = the programmed value of parameter “ABSORP EXIT AMPS” (Default value is 4A. For details of programming range & procedure, refer to Section 4.4.2.20 of EVO-RC-PLUS Remote Control Manual) Reset to Bulk Stage under the following conditions: <ul style="list-style-type: none"> i. If the AC input from the Grid/Generator is disconnected and is reconnected. ii. If battery voltage falls to the programmed value of parameter “RESET TO BULK” (Default value is 12.0V for EVO-1212F/1212F-HW and 24.0V for EVO-1224F/1224F-HW. For details of programming range & procedure, refer to Section 4.4.2.15 of EVO-RC-PLUS Remote Control Manual). 	<p>– Lithium (See Section 5.11)</p> <p>– Nickel Zinc (See Section 5.10)</p>

SECTION 5 | Battery Charging in Evolution™ Series

5.11 CHARGING LITHIUM ION BATTERIES



CAUTION!

The Battery Management System (BMS) that comes with the Lithium Ion Battery being used may need to have control over charging and discharging of the battery. For this, any of Pins 1/2/3/4 and any of Pins 5/6/7/8 of the Temperature Sensor Jack (6, Fig 2.1; Pinout at Fig 3.13) may be used to feed potential free contact closing signal from the BMS to "Stop Charging" or "Stop Inverting". See Section 5.11.2 below for details.



ATTENTION!

Le système de gestion de la batterie (BMS) qui vient avec la batterie au lithium-ion utilisé peut avoir besoin d'avoir le contrôle de charge et décharge de la batterie. Pour cela, n'importe lequel des broches 1/2/3/4 et 5/6/7/8 de la prise de capteur de température (6, Fig. 2.1; Pinout à la Fig. 3.13) peut être utilisé pour l'alimentation contact libre de signal de fermeture de la BMS à "arrêter la charge" ou "arrêter d'inverser". Se reporter à la Section 5.11.2 pour plus de détails.

5.11.1 Charging Profiles for Lithium Batteries

Programming parameter "CHARGING PROFILE" is used to select up to 5 programming options for 2/3-Stage charging profiles for Lithium Ion Batteries. Details are given in Table below:

Srl. No. Table 5.2	Srl. No. of Table 5.3	Option under Parameter "CHARGING" Profile (Section 4.4.4.2.21 of EVO-RC Remote Control Manual attached at Appendix A
2	—	" 1 = 3-Stage Type 1 "
3	—	" 2 = 3-Stage Type 2 "
—	1	" 3 = 2-Stage Type 1 "
—	2	" 4 = 2-Stage Type 2 "
—	3	" 5 = 2-Stage Type 3 "



INFO

Charging of Lithium Ion Batteries is not affected by temperature and hence, Battery Temperature Sensor Model EVO-BCTS [Fig 2.5(a)] is not required to be used

5.11.2 Stop Charging and Stop Inverting Protections when Charging Lithium Batteries

For background information, refer to Section 4.4.2.22.2 in the EVO-RC-PLUS Remote Control Manual. For protection against over-voltage / over-temperature / over-discharge, Lithium Ion Battery Management Systems (BMS) will normally

SECTION 5 | Battery Charging in Evolution™ Series

have capability of providing potential free relay contact closure signal that could be fed to Inverter Charger to stop charging or stop inverting. For this, the BMS will normally use miniature, Normally Open (1-Form-A), Open Drain Opto-Isolated DC Solid-State Relay (SSR). The Solid-State Relay output terminals in the BMS are normally marked "+" (Drain of Mosfet Switch) and "-" (Source of Mosfet Switch). Example of this type of relay is IXYS Part No. "CPC 1002N" (60V, 700mA rating).

The following 2 types of signals are normally used by the BMS for on/off control of charging and inverting operation of the Inverter-Charger:

- **"Stop Charging" Signal:** In case of (i) over voltage of individual cell / overall battery pack, or (ii) over temperature of individual cell or overall battery pack, the signal will be "enabled" and SSR contacts will close [Drain (+) and Source (-) Terminals will be shorted].
- **"Stop Inverting" Signal:** In case of deep discharge of the battery to the level of Low Battery Cut Off Voltage, the signal will be "enabled" and the SSR contacts will close [Drain (+) and Source (-) Terminals will be shorted].

If the above two protection functions of the BMS i.e. "Stop Charging" and "Stop Inverting" are to be used for on / off control of charging and inverting operations of EVO Inverter-Charger, the following actions will be required to be undertaken:

- a) Programming parameter **"BATTERY TYPE"** must be changed from Option 1 - "0=Lead Acid" (Default setting) to Option 2 - "1=Lithium" [See Section 4.4.2.22 of EVO-RC-PLUS Remote Control Manual]. With this setting, the function of front panel RJ-45 Jack marked "Battery Temp. Sensor: (6, Fig 2.1) will change from accepting and processing battery temperature signal from the Battery Temperature Sensor EVO-BCTS to accepting and processing potential free relay contact closure signal from the Solid-State Relay from the BMS to stop charging /inverting.
- b) **Wiring Connection:** Output from the SSR Terminals on the Lithium Battery BMS should be wired to the RJ-45 Jack marked "Battery Temp. Sensor" (6, Fig 2.1) as follows:
 - Connect terminal marked "+" on the SSR (Drain of Mosfet switch inside SSR) to any of pins 1/2/3/4 of RJ-45 Jack (Pinout shown below)
 - Connect terminal marked "-" on the SSR (Source of Mosfet switch inside SSR) to any of pins 5/6/7/8 of RJ-45 Jack (Pinout shown below)

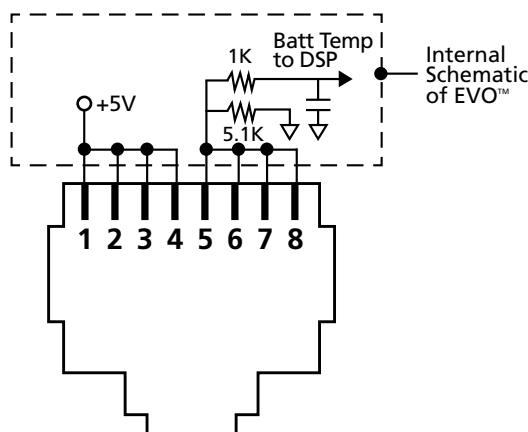

Pinout of RJ-45 Jack (marked "Battery Temp. Sensor") on the Front Panel of EVO (6, Fig 2.1)

SECTION 5 | Battery Charging in Evolution™ Series

When the Drain-Source terminals of the BMS close, Pins 1/2/3/4 and 5/6/7/8 of RJ-45 Jack will be shorted. The following actions will be activated in EVO:

- **EVO in Charging Mode:** Charging will stop (Internally, the EVO will be in Charging Mode, but the charging current will be reduced to 0A). Charging Mode Screens in EVO-RC-PLUS Remote Control will show message "Charger Off by BMS" [Refer to display screens shown in Fig 3.7 under Section 3.6.8 of EVO-RC-PLUS Remote Control Manual].
- **EVO in Inverting Mode:** Inverting will stop (Internally, the EVO will enter Standby Mode). Inverting Mode Screens in EVO-RC-PLUS Remote Control will show message "Inverter Stop by BMS" [Refer to display screens shown in Fig 3.8 under Section 3.6.9 of EVO-RC-PLUS Remote Control Manual].

5.12 OPERATING MODE OPTION - "CHARGER ONLY"

In Off-grid DC powered homes, for efficiency consideration, all lighting and other loads / appliances are normally powered from 12V batteries that are primarily charged through solar / wind power. Generator backup is used for powering AC to DC battery charger for charging the batteries during extended periods of cloudy / no wind conditions. To meet this requirement, the EVO™ can be programmed to operate as a battery charger ONLY i.e. when AC input power is available within the programmed limits of voltage and frequency, charging will take place and AC input will be passed through to the load(s). The unit will not transfer to Inverting Mode if AC input fails or is outside the programmed limits of voltage and frequency. For further details refer to Section 4.4.2.13.1 in EVO-RC-PLUS Remote Control Manual.

SECTION 6 | Operation, Protections and Troubleshooting



CAUTIONS!

- a) Please ensure that all safety instructions at Section 1 of this manual are read and understood before operating the unit
- b) Please ensure that the unit has been installed properly as per instructions at Section 3 of this manual



ATTENTIONS!

- a) *Veillez vous assurer que toutes les instructions de sécurité de la Section 1 de ce manuel sont lues et comprises avant d'utiliser l'appareil.*
- b) *Veillez vous assurer que l'appareil a été installé correctement conformément aux instructions de la section 3 de ce manuel.*



INFO

Please ensure that charged battery has been connected to the DC Input Terminals (1 and 2 in Fig2.1). This unit will NOT operate if specified battery voltage as shown below is not available at the DC Input terminals:

- a) 12V units i.e. EVO-2212/3012..... $\geq 9.1\text{VDC}$
- b) 24V units i.e. EVO-2224/4024..... $\geq 18.1\text{VDC}$

6.1 POWERING ON / POWERING OFF USING FRONT PANEL ON/OFF BUTTON (11, FIG 2.1)



INFO

For power on / power off sequence using EVO-RC-PLUS Remote Control, refer to Section 3.2 of EVO-RC-PLUS Remote Control Manual.

6.1.1 Manual Power on Sequence when AC Input is in Switched Off condition / Not Connected:

To power ON the unit, press and hold the ON/OFF Button on the front panel (11, Fig 2.1) for around 3 seconds until completion of sequence shown below:

- Blue LED marked "ON" (12, Fig 2.1) will blink 3 times, will go off momentarily and will then be steady Blue. Now, release the ON/OFF Button. Subsequently, the lighting pattern of this LED will be controlled by various operating conditions given in Table 6.1

NOTE: *For Power on / off sequence when using the optional Remote Control EVO-RC-PLUS, please refer to Section 3.2 of EVO-RC-PLUS Remote Control Manual.*

SECTION 6 | Operation, Protections and Troubleshooting

6.1.2 Automatic Power on Sequence when AC Input Power is in Switched on Condition:

Automatic "Power on Sequence" will be initiated if:

- i. AC input power $> 70 \pm 5\text{VAC}$ is made available at the AC Input Terminals and,
- ii. The battery voltage is $> 12\text{V}$ for EVO-1212F / 1212F-HW and $> 24\text{V}$ for EVO-1224F / 1224F-HW. If no fault condition(s) is detected, the unit enters "Charging Mode" if AC input power is within the programmed limits of voltage and frequency or Inverting Mode if AC input power is NOT within the programmed limits of voltage and frequency.

NOTE: *For power on / power off Sequence when using the optional Remote Control EVO-RC-PLUS, please refer to Section 3.2 of EVO-RC-PLUS Remote Control Manual.*

6.1.3 Power off Sequence:

6.1.3.1 Power off Sequence when AC Input is in Switched off Condition / Not Connected:

When the AC input is in switched off condition / not connected and the unit is in ON condition, the unit will be operating in Inverting Mode and the Blue LED marked "ON (12, Fig 2.1) will be in steady ON condition.

To power OFF the unit, press and hold the ON/OFF Button (11, Fig 2.1) for around 5 seconds. Wait for the Blue LED marked "ON" (12, Fig 2.1) and Red LED marked "FAULT / ALARM" (13, Fig 2.1) to light steady and then release the ON/OFF Button. The unit will power OFF after the ON/OFF Button is released. **[NOTE: "Power off Sequence" will complete ONLY when the Power ON/OFF Button is released!]**

NOTE: *For Power on / off Sequence when using the optional Remote Control EVO-RC-PLUS, please refer to Section 3.2 of EVO-RC-PLUS Remote Control Manual)*

6.1.3.2 Power off Sequence when AC Input Power is in Switched on Condition (AC Input Voltage $> 70 \pm 5\text{VAC}$)

Please note that as long as AC input voltage $> 70 \pm 5\text{VAC}$ is available at the AC Input Terminals, the unit ***CANNOT BE POWERED OFF*** using the On/Off Button on the front panel of the unit or the On/Off Key on the optional Remote Control EVO-RC-PLUS [See Section 3.2.2 of EVO-RC-PLUS Remote Control Manual]. **Switch off the AC input power first if the unit is required to be powered off.** However, if the unit is in "Fault Mode", it will be possible to power off the unit with the help of On/Off Button on the front panel of the unit or the On/Off Key on the optional Remote Control EVO-RC-PLUS.

NOTE: *For Power on / off Sequence when using the optional Remote Control EVO-RC-PLUS, please refer to Section 3.2 of EVO-RC Remote Control Manual.*

6.2 POWERING ON / OFF BY FEEDING EXTERNAL +12V SIGNAL TO TERMINALS MARKED "REMOTE ON/OFF" ON THE FRONT PANEL

The unit can be switched ON /OFF remotely by feeding specified format of +12VDC (+9 to 15VDC, $< 10\text{mA}$) signal to terminals marked "Remote On / Off" on the Front Panel (15, Fig 2.1). The specified +12V signal format has 2 options –

SECTION 6 | Operation, Protections and Troubleshooting

“Button Type” or “Switch Type”. These 2 signal format options can be programmed using the optional Remote Control EVO-RC-PLUS. These options are available under programmable parameter called “REMOTE SWITCH”. *Please refer to the following Sections of the EVO-RC-PLUS Remote Control Manual:*

- *Section 4.1.3.3, Fig 4.4: Screen No. 4*
- *Section 4.8.1, Table 4.5: Srl No. 4 “REMOTE SWITCH”
– 0=Button Type (Default); 1=Switch Type*
- *Section 4.8.2.4: Detailed explanation of programmable parameter REMOTE SWITCH*

6.2.1 Button Type On/Off Control Using +12V Signal (Default)

This type of external +12V signal format is used when the signal is fed through an external series connected Push Button [*+12V will be fed as long as the Push Button is kept pressed*]. Control logic used is as follows:

- When the EVO™ is in OFF condition, momentary feeding of +12V signal through the external Push Button for > 2 sec will turn the unit ON. The EVO™ will remain ON even when the Push Button is released
- When the EVO™ is in ON condition, momentary feeding of +12V signal through the external Push Button for > 5 sec will turn the EVO™ OFF.

NOTE: *If the external Push Button is pressed for < 5 sec, the unit will NOT switch OFF*

6.2.2 Switch Type On/Off Control Using +12V Signal

This type of external +12V signal format is used when the +12V signal (+9 to 15 VDC, < 10mA) is fed through an external, series connected On/Off Toggle / Rocker Switch or Relay contact (+12V signal will be fed continuously when the switch in ON condition / Relay contact is closed and +12V signal will be removed when the external On/Off switch is in OFF condition or the Relay contact is open). Example of this type of Remote On/Off Control signal format is the Ignition Switch in a vehicle. When the Ignition Switch is ON, 12V from the vehicle battery will be available. When the Ignition Switch is OFF, 12V will be switched OFF. Control logic used is as follows;

- When the external On/Off Switch is turned ON or when the Relay contact is closed, continuous +12V control signal will be made available and the EVO™ will turn ON. EVO™ will remain ON as long +12V control signal is available through the ON condition of the external On/Off Switch or the closed Relay contact
- When the external On/Off Switch is turned OFF or if the Relay contact opens, the +12V signal will be removed and the EVO™ will switch OFF



CAUTION!

When “Switch Type” of ON/OFF control described at Section 6.2.2 above is selected, the ON/OFF Button on the front panel of the unit (12, Fig 2.1) should NOT be used to turn ON or turn OFF the unit. The front panel ON/OFF Push Button will now follow the above “Switch Type” control logic wherein the unit will remain ON only as long as the Button is kept pressed and will turn OFF in 2 seconds after it is released.

SECTION 6 | Operation, Protections and Troubleshooting



ATTENTION!

Lorsque « Switch Type » de ON/OFF contrôle décrit ci-dessus est sélectionnée, le bouton on/off sur le panneau avant de l'unité (12, Fig 2.1) ne devraient pas servir à allumer ou éteindre l'appareil. La façade, bouton poussoir On/Off suivra désormais la logique de contrôle ci-dessus « Switch Type » dans lequel l'appareil demeurera allumé aussi longtemps que la touche est maintenue enfoncée et s'éteint après 2 secondes après que qu'il est libéré.

6.3 OPERATIONAL INFORMATION THROUGH LEDS AND BUZZER

Table 6.1 shows the operational states of the unit indicated by the following LEDs on the front panel of the unit and Buzzer:

- Blue LED marked "ON" (12, Fig 2.1)
- Red LED marked "Fault" (13, Fig 2.1)

Optional Remote Control Model EVO-RC-PLUS will be required for more detailed messaging that is available through its LCD display and LEDs. *This remote will also be required for programming of various parameters to suit specific requirements.*

TABLE 6.1 FRONT PANEL LED AND BUZZER INDICATIONS			
Status	Blue LED marked "ON" (12, Fig 2.1)	Red LED marked "Fault" (13, Fig 2.1)	Buzzer (See NOTE 1 Below)
Seen during Power-On Sequence (Refer to Section 6.1.1)	Blink 3 times & then off	Off	Off
Seen during Power-Off Sequence (Refer to Section 6.1.2)	On	On	Off
Normal charging	Blink once in 1 sec interval	Off	Off
Equalization charging	Blink twice in 1 sec interval	Off	Off
Inverting (Discharging)	On	Off	Beep once in 3 sec interval
Low battery alarm	On	Blink once in 1 sec interval	Beep once in 1 sec interval
Power saving	Blink once in 3 sec interval	Off	Off
Standby	Blink once in 5 sec interval	Off	Off
Fault	Off	On	On

NOTE 1:

The buzzer can be switched on or off through programming parameter "BUZZER" [Refer to Section 4.8.2.7 of EVO-RC-PLUS Manual. The default setting is "1 = On"].

SECTION 6 | Operation, Protections and Troubleshooting

6.4 OPTIONAL REMOTE CONTROL EVO-RC-PLUS FOR PROGRAMMING OF MODES OF OPERATION AND PARAMETERS

Optional Remote Control Model EVO-RC-PLUS [Fig 2.4(a)] will be required for more advanced control and monitoring. Please see separate Owner's Manual for EVO-RC-PLUS. The Remote Control comes with 10M / 33 ft., RJ-45 Data Cable. The Remote plugs into RJ-45 Jack on the front panel of the unit (7, Fig 2.1). It has provision for Data Logging using SD Card of up to 16 GB (FAT16 / FAT32). It also has its own Real Time Clock and Super Capacitor Type of Battery.

Detailed messaging is available through its LCD display and LEDs. This remote will also be required for programming of various parameters to suit specific requirements. Each programmable parameter has a Default Value. This unit has been shipped with the various parameters set at the Default Values.

6.4.1 Programmable & Default Values of Programming Parameters

Programmable and Default values are shown in Tables 6.2 to 6.6:

TABLE 6.2 PROGRAMMABLE AND DEFAULT PARAMETERS: PARAMETER GROUP NO.1 "CHARGING CURVE"				
Parameter	Programming Range (Programming requires optional Remote Control Model EVO-RC-PLUS)		Default	
	EVO-1212F EVO-1212F-HW	EVO-1224F EVO-1224F-HW	EVO-1212F EVO-1212F-HW	EVO-1224F EVO-1224F-HW
"BULK CURRENT" (See NOTE 1) (Bulk Charge Current "I _o ")	0-60A	0-40A	20A	
"ABSORP VOLTAGE" (Absorption Voltage)	12.00V - 16.00V	24.00V - 32.00V	14.40V	28.80V
"EQUALIZE VOLTAGE" (Equalization Voltage)	14.00V - 16.50V	28.00V - 33.00V	14.40V	28.80V
"FLOAT VOLTAGE" (Float Voltage)	12.00V - 15.00V	24.00V - 30.00V	13.50V	27.00V
"COMPENSATE" (Temperature Compensation)	3mV to 5mV /C/Cell		4mV /C/Cell	
"BATT OVER VOLT" (Battery Over Voltage Shutdown)	14.00V - 17.00V	28.00V - 35.00V	16.00V	32.00V
"RESET VOLTAGE" (Reset voltage for "BATT LOW VOLTAGE" condition)	12.00V - 17.00V	24.00V - 35.00V	14.00V	28.00V
"LOW VOLT ALARM" (Battery Low Voltage Alarm)	9.50V to 13.50V	19.00V to 27.00V	11.00V	22.00V
"BATT LOW VOLTAGE" (Battery Low Voltage Shutdown)	>9.00V to 13.00V	>18.00V to 26.00V	10.50V	21.00V

SECTION 6 | Operation, Protections and Troubleshooting

"LV DETECT TIME" (Time to qualify "BATT LOW VOLTAGE" condition)	0 - 600 sec		10 sec	
"LV CUT OFF TIME" (Time in "BATT LOW VOLTAGE" condition to trigger complete shutdown)	0 - 7200 sec		1200 sec	
"EQUALIZE-4STAGES" (4 Stage Adaptive Equalization On/ Off)	0 = No (3-Stage / 2-Stage) 1 = Yes (4-Stage Equalization)		0 = No (3-Stage / 2-Stage)	
"MODE"	0 = Normal...AC input priority (Off-Line) 1 = On-Line...Inverter priority 2 = Charger Only...Charging & AC bypass only, no inverting		0 = Normal	
"ONLINE OPTION" (Available only when parameter "MODE" is set to option "1=On-Line")	0 = Option 1 1 = Option 2		0 = Option 1	
"RESET TO BULK"	10.00V to 13.00V	20.00V to 26.00V	12.00V	24.00V
"GS DETECT TIME"	0 - 600 sec		10 sec	
"GEN ON TIME"	0 - 240 min		60 min	
"GEN OFF DELAY"	0 - 240 min		60 min	
"ABSORP TIME"	0 - 600 min		60 min	
"ABSORP EXIT AMPS"	0 - 20A		4A	
"CHARGING PROFILE"	0 = 3 Stage Adaptive 1 = 3 Stage Type 1 2 = 3 Stage Type 2 3 = 2 Stage Type 1 4 = 2 Stage Type 2 5 = 2 Stage Type 3		0 = 3 Stage Adaptive	
"BATTERY TYPE"	0 = Lead Acid 1 = Lithium		0 = Lead Acid	
"SAFE CHARGING"	0 - 300 min		0 min	
"EXT. CHARGER"	0 = Affect 1 = Not affect		0 = Affect	
NOTE 1: "BULK CURRENT" value may automatically reduce in higher ambient temperatures of around 50° - 60°C if Power Transformer temperature exceeds 130°C or Heat Sink temperature exceeds 65°C. <i>(See Section 4.9.3)</i>				

SECTION 6 | Operation, Protections and Troubleshooting

Group	Parameter name	Programming Range		Default value	
		EVO-1212F EVO-1212F-HW	EVO-1224F EVO-1224F-HW	EVO-1212F EVO-1212F-HW	EVO-1224F EVO-1224F-HW
INPUT SETTING	DEFAULT FREQ	0 = 60Hz*		0 = 60Hz*	
	GRID MAX CURRENT	5 - 20A		20A	
	HIGH CUT OFF	50 – 70Hz		65Hz	
	HIGH RESET	50 – 70Hz		64Hz	
	LOW CUT OFF	40 – 60Hz		55Hz	
	LOW RESET	40 – 60Hz		56Hz	
	SYNCHRONIZATION	0 = Fine ; 1 = Coarse		0 = Fine	
	INPUT OC PROTECT	0 = INV Mode ; 1 = Shutdown		0 = INV Mode	
INPUT RECOVERY	0 = Buffered ; 1 = Direct		0 = Buffered		

* Fixed at 60 Hz. Changing to other option 0 (say 1), will show "!1=xxHz" meaning option 1 is invalid

Group	Parameter name	Setting range		Default value	
		EVO-1212F EVO-1212F-HW	EVO-1224F EVO-1224F-HW	EVO-1212F EVO-1212F-HW	EVO-1224F EVO-1224F-HW
INPUT - LOW LIMIT	RESET VOLTAGE	60.0 – 120.0V		105.0V	
	CUT OFF VOLT 1	60.0 – 120.0V		100.0V	
	DETECT TIME 1	0 – 2000 cycle		300 cycle	
	CUT OFF VOLT 2	60.0 – 120.0V		95.0V	
	DETECT TIME 2	0 – 2000 cycle		60 cycle	
	CUT OFF VOLT 3	60.0 – 120.0V		90.0V	
	DETECT TIME 3	0 – 2000 cycle		1 cycle	

Group	Parameter name	Setting range		Default value	
		EVO-1212F EVO-1212F-HW	EVO-1224F EVO-1224F-HW	EVO-1212F EVO-1212F-HW	EVO-1224F EVO-1224F-HW
INPUT - HIGH LIMIT	RESET VOLTAGE	120.0 – 150.0V		125.0V	
	CUT OFF VOLT 1	120.0 – 150.0V		135.0V	
	DETECT TIME 1	0 – 2000 cycle		60 cycle	
	CUT OFF VOLT 2	120.0 – 150.0V		140.0V	
	DETECT TIME 2	0 – 2000 cycle		15 cycle	
	CUT OFF VOLT 3	120.0 – 150.0V		145.0V	
	DETECT TIME 3	0 – 2000 cycle		1 cycle	

SECTION 6 | Operation, Protections and Troubleshooting

TABLE 6.6 PROGRAMMABLE AND DEFAULT PARAMETERS: PARAMETER GROUP NO.5 "OTHER FUNCTIONS"				
Parameter name	Setting range		Default Value	
	EVO-1212F EVO-1212F-HW	EVO-1224F EVO-1224F-HW	EVO-1212F EVO-1212F-HW	EVO-1224F EVO-1224F-HW
"POWER SAVING"	1 = Enable 0 = Disable		0 = Disable	
• "ENTER POINT"	4 – 50W		6W	
• "WAKE UP POINT"	5 – 50W		7W	
<p>"REMOTE SWITCH"</p> <ul style="list-style-type: none"> For ON /OFF control through external 12V signal fed to Remote ON / OFF terminals on the Front Panel (15, Fig 2.1) 	<p>0 = Button Type: 12V signal is fed through Push Button Type of Switch</p> <ul style="list-style-type: none"> Pressing of Push Button > 2 sec will switch the unit ON When ON, pressing Push Button > 5 sec will turn the unit OFF <p>1 = Switch Type: 12V signal is fed through contacts of Toggle Type of Switch or relay contact</p> <ul style="list-style-type: none"> ON condition (contacts closed) will turn the unit ON OFF condition (contacts open) for 2 sec will switch the unit OFF 		<p>0 = Button Type</p> <p>CAUTION! ON/OFF Logic also controls the operation of the ON/OFF Button on the front panel (11, Fig 2.1). The Default setting is "Button Type". If the ON/OFF Control is changed to external "Remote Switch", it will not be possible to switch ON/OFF the EVO Inverter/Charger from the front panel ON/OFF Push Button because it will work with Switch Type Logic. It will be ON only as long as the Push Button is kept pressed and will switch OFF when released.</p>	
<p>"RELAY FUNCTION"</p> <p>(for Status Relay)</p>	<p>0 = Charge / Other</p> <ul style="list-style-type: none"> OFF in "Charging" Mode ON in other Modes i.e. "Inverting", "Power Saving" or "Standby" <p>1 = Normal / Fault</p> <ul style="list-style-type: none"> OFF in normal operating conditions ON in Fault Modes <p>2 = Generator 0</p> <ul style="list-style-type: none"> ON when batteries drop to "LOW VOLT ALARM" or lower for period = "GS DETECT TIME" - Initiates Generator start OFF after batteries are charged till the end point of the programmed option under parameter "CHARGING PROFILE" [See Section 4.8.2.5.2.1 of EVO-RC-PLUS Remote Control Manual]. When the relay switches OFF, it initiates Generator Stop. <p>3 = Generator 1</p> <ul style="list-style-type: none"> ON when batteries drop to "LOW VOLT ALARM" or lower for period = "GS DETECT TIME" - initiates Generator start OFF when batteries are charged to "RESET VOLTAGE" for period = "GEN OFF TIME" - initiates Generator stop <p>4 = Generator 2</p> <ul style="list-style-type: none"> ON when batteries drop to "LOW VOLT ALARM" or lower for period = "GS DETECT TIME" - initiates Generator start OFF after period = "GEN ON TIME" from the time relay switched ON - initiates Generator stop 		<p>2 = Generator 0</p>	

Table continues on next page ►

SECTION 6 | Operation, Protections and Troubleshooting

TABLE 6.6 PROGRAMMABLE AND DEFAULT PARAMETERS: PARAMETER GROUP NO.5 "OTHER FUNCTIONS" (Continued)				
Parameter name	Setting range		Default Value	
	EVO-1212F EVO-1212F-HW	EVO-1224F EVO-1224F-HW	EVO-1212F EVO-1212F-HW	EVO-1224F EVO-1224F-HW
"Remote SW Delay"	0-300 Seconds Setting a time will delay turning ON the inverter when using the "Remote Switch" input terminals for the programmed amount of time. Applies only when "Remote Switch" is set to "1=Switch Type".		000	
"COMM ID" (Communication ID for optional Remote Control EVO-RC-PLUS)	1 - 255		1	
"BUZZER"	0 = OFF ; 1 = ON		1 = On	
"DISCHARGE BEEP" (Beeping in "Discharging / Inverter Mode")	0 = OFF ; 1 = ON		0 = Off	
"DEFAULT RESET"	0 = No ; 1 = YES		0 = No	
DATA LOG TIME (For Optional Remote Control EVO-RC-PLUS)	0 = Disable 3 = 30 sec 6 = 10 min 1 = 1 sec 4 = 1 min 2 = 10 sec 5 = 5 min		1 = 1 sec	
PARAMETER SAVE (For Optional Remote Control EVO-RC-PLUS)	0 = No 1 = Yes		0 = No	
TEMP UNIT	0 = C 1 = F		0 = C	
PASSWORD DISABLE	0 = No 1 = Yes		0 = No	

6.5 PROTECTIONS, FAULT MESSAGES AND TROUBLESHOOTING GUIDE

The front panel of the unit has a Red LED marked "FAULT" (13, Fig 2.1). This LED will light up (steady) when the unit registers any of the **FAULT MODE** situations shown in Table 7.1 of EVO-RC-PLUS Remote Control Manual.

Table 7.1 of EVO-RC-PLUS Remote Control Manual shows details of protections and associated Fault/Error Messages that will be displayed on the LCD screen of the optional Remote Control EVO-RC-PLUS.

NOTE: If the optional Remote Control EVO-RC-PLUS is not used, it may be difficult to narrow down the probable cause of the fault.

SECTION 6 | Operation, Protections and Troubleshooting

6.6 POWERING OFF THE UNIT IN FAULT MODE

If the unit is in “Fault Mode”, it will be possible to power OFF the unit with the ON/OFF Push Button on the front panel of EVO™ (11, Fig 2.1).

As explained under Section 6.1.3, as long as AC input voltage $> 70 \pm 5$ VAC is present, the unit CANNOT BE POWERED OFF using the ON / OFF Button on the front panel of the unit or on the optional Remote Control EVO-RC *[See Section 3.2.2 of EVO-RC-PLUS Remote Control Manual]*. In order to power off using the Power ON/Off Button, switch OFF the AC input first.

6.7 12V, 100MA CAPACITY DC SOURCE FOR SIGNALING

A 12V, 100mA capacity DC source has been provided (16, Fig 2.1). This voltage may be routed through the contacts of the Status Relay (14, Fig 2.1) to feed 12V ON / OFF control signal to drive circuits of remote monitoring control of the programmable conditions of operation of the unit *[Refer to Section 4.8.2.5.1 of EVO-RC-PLUS Remote Control Manual]*.

6.8 STANDBY MODE

When the EVO™ is in Standby Mode, it will stop inverting or charging / pass through.

6.8.1 General Information



1. Standby Mode may also be used to temporary halt normal operation of the Inverter Charger without switching OFF the unit completely.
2. EVO-RC-PLUS Remote Control is required for switching ON/ switching OFF Standby Mode. Switching ON/ OFF of Standby Mode CANNOT be carried out from the ON/ OFF button on the front panel of EVO unless EVO-RC-PLUS Remote Control has been connected to the EVO unit.

For the Standby Mode to be switched ON, the EVO™ should be in ON condition and should be operating in one of the 3 Operating Modes – “Inverting” or “Charging” or “Power Save” *[See Figs 3.1(a), 3.2(a) and 3.3(a) of EVO-RC-PLUS Manual]*. When Standby Mode is switched ON, the EVO™ will exit its Operating Mode.

6.8.2 Procedure to Enter and Exit Standby Mode / Status Display in Standby Mode

6.8.2.1 *For procedure to enter and exit Standby Mode, please refer to Section 3.4.1 of EVO-RC-PLUS Remote Control Manual.*

SECTION 7 | Specifications

Models	EVO-1212F EVO-1212F-HW	EVO-1224F EVO-1224F-HW
INVERTER SECTION		
Output Waveform	Pure Sine Wave	
Input Battery Voltage Range	9.1 - 17 VDC	18.1 - 34 VDC
Nominal AC Output Voltage	120 VAC \pm 5%; Single Phase	
Output Frequency	60 Hz \pm 0.1 Hz	
Total Harmonic Distortion of Pure Sine Wave Form (THD)	< 5%	
Continuous Output Power and Power Factor (PF)	1200 Watt at PF = 0.95	
Continuous AC Output Current	10A	
Surge Power for 1 msec	300% (3600VA, 30A)	
Surge Power for 100 msec	200% (2400VA, 20A)	
Power Boost for 30 sec	150% (1800W at PF = 0.95)	
Power Boost for 1 min	140% (1680W at PF = 0.95)	
Power Boost for 10 min	120% (1440W at PF = 0.95)	
Power Boost for 30 min	110% (1320W at PF = 0.95)	
Maximum Continuous DC Input Current	152A	76A
Inverter Efficiency (Peak)	89%	91%
No Load Power Consumption in Power Saving Mode	< 8 W	
No Load Power Consumption in Normal Mode (120 VAC Output, Typical)	20 watts	20 watts
No load Power Consumption in Standby Mode (Inverting/ Charging are suspended)	< 5W	
AC INPUT		
AC Input Voltage	120VAC (60-140VAC +/- 5% selectable)	
AC Input Frequency	60Hz	
Maximum Programmable AC Input Current (GRID MAX CURRENT)	5 - 20A (Default - 20A)	
AC Input Breaker Size	20A (i) EVO-1212F and EVO-1224F have built-in Breaker (ii) For EVO-1212F-HW and EVO-1224F-HW, breaker has to be installed externally by the installer / user.	

SECTION 7 | Specifications

Models	EVO-1212F EVO-1212F-HW	EVO-1224F EVO-1224F-HW
INPUT AND OUTPUT CONNECTIONS		
Battery Connection	• Stud and Nut: M8 (Pitch 1.25mm)	
External Charge Controller Connection	• Stud and Thumb Nut: M6 (Pitch 1mm)	
AC Input Connection	(i) EVO-1212F and EVO-1224F: • IEC 60320 C-20 Male Power Inlet Plug. Requires 20A Detachable Power Cord with mating IEC 60320 C-19 Socket Connector and NEMA5-20P Plug (ii) EVO-1212F-HW and EVO-1224F-HW: • Terminal Block	
AC Output Connection	(i) EVO-1212F and EVO-1224F: • NEMA5-15P, Duplex GFCI Outlet, 15A (ii) EVO-1212F-HW and EVO-1224F-HW: • Terminal Block	
OPTIONAL REMOTE CONTROL		
Model No.	• EVO-RC-PLUS	
Specifications	• Advanced Features for programming various parameters and modes of operation • 4 Rows of 20 Character Alpha Numeric LCD Display for messaging • Up to 16 GB SD Card Slot for Data Logging • Comes with 10M / 33ft RJ-45 Data Cable	
COMPLIANCE		
Safety Compliance	• Intertek-ETL listed: Certified to CAN / CSA STD. C22.2 No. 107.1-01 • Intertek-ETL listed: Conforms to ANSI / UL STD. 458	
EMI / EMC Compliance	• Certified to FCC Part 15(B), Class A	
ABYC Compliance	• Meets ABYC A-31 and ABYC E-11 • Meets Ignition Protection SAE-J1171 and ISO 8846	
ENVIRONMENTAL SPECIFICATIONS		
Operating Temperature	-20° C to +60° C (-4° F to 140° F)	
Storage Temperature	-40° C to +70° C (-40° F to 158° F)	
Operating Humidity	0 to 95% RH non condensing	
WEIGHTS AND DIMENSIONS		
Dimensions: W x D x H	324 x 415 x 148 mm; 12.76 x 16.34 x 5.83 in	
Weights:	17.6 Kg / 38.8 lb	17.6 Kg / 38.8 lb

NOTES:

- (1) All AC power ratings in the Inverter Section are specified at Power Factor = 0.95
- (2) All specifications given above are at ambient temperature of 25°C / 77°F unless specified otherwise
- (3) Specifications are subject to change without notice

SECTION 8 | Warranty

3 YEAR LIMITED WARRANTY

EVO™ Series Inverter/Chargers manufactured by Samlex America Inc. (the “Warrantor”) are warranted to be free from defects in workmanship and materials under normal use and service. The warranty period is 3 years for the United States and Canada, and is in effect from the date of purchase by the user (the “Purchaser”).

Warranty outside of the United States and Canada is limited to 6 months. For a warranty claim, the Purchaser should contact the place of purchase to obtain a Return Authorization Number.

The defective part or unit should be returned at the Purchaser’s expense to the authorized location. A written statement describing the nature of the defect, the date of purchase, the place of purchase, and the Purchaser’s name, address and telephone number should also be included.

If upon the Warrantor’s examination, the defect proves to be the result of defective material or workmanship, the equipment will be repaired or replaced at the Warrantor’s option without charge, and returned to the Purchaser at the Warrantor’s expense. (Contiguous US and Canada only) using a carrier of the warrantor’s choice.

Warranty service shall be performed only by the Warrantor. Any attempt to remedy the defect by anyone other than the Warrantor shall render this warranty void. The warranty does not apply to units with a serial number that has been altered, removed or modified in any way.

There is no warranty for defects or damages to equipment or parts caused by:

- Installation, alternation, inspection or removal
- Normal wear and tear
- Abuse or misuse of the equipment including exposure to excessive heat, salt or fresh water spray, or water immersion
- Corrosion, fire, lightening, biological infestations or Acts of God
- Repairs attempted by anyone other than the Warrantor
- Improper use, contrary to operational instructions provided in product manual
- Shipping or transport

No other express warranty is hereby given and there are no warranties which extend beyond those described herein. This warranty is expressly in lieu of any other expressed or implied warranties, including any implied warranty of merchantability, fitness for the ordinary purposes for which such goods are used, or fitness for a particular purpose, or any other obligations on the part of the Warrantor or its employees and representatives.

There shall be no responsibility or liability whatsoever on the part of the Warrantor or its employees and representatives for injury to any persons, or damage to person or persons, or damage to property, or loss of income or profit, or any other consequential or resulting damage which may be claimed to have been incurred through the use or sale of the equipment, including any possible failure of malfunction of the equipment, or part thereof. The Warrantor assumes no liability for incidental or consequential damages of any kind.

Samlex America Inc. (the “Warrantor”)

www.samlexamerica.com

Contact Information

Toll Free Numbers

Ph: 1 800 561 5885

Fax: 1 888 814 5210

Local Numbers

Ph: 604 525 3836

Fax: 604 525 5221

Website

www.samlexamerica.com

USA Shipping Warehouses

Kent, WA

Plymouth, MI

Canadian Shipping Warehouse

Richmond, BC

Email purchase orders to
orders@samlexamerica.com



samlexamerica®