



samlexpower®

**DC-AC
Inverters**

PSE-12125A
PSE-12175A
PSE-12275A

**Owner's
Manual**

Please read this
manual BEFORE
installing your
inverter





OWNER'S MANUAL | Index

SECTION 1: Safety Instructions..... 3

SECTION 2: General Information on Inverters..... 6

SECTION 3: Characteristics of Sinusoidal AC Power 9

SECTION 4: AC Power Distribution & Grounding 10

SECTION 5: Limiting Electromagnetic Interference (EMI)..... 14

SECTION 6: General Information on Lead Acid Batteries 15

SECTION 7: Layout, Controls & Indications 27

SECTION 8: Principle of Operation 30

SECTION 9: Installation 32

SECTION 10: Operation..... 39

SECTION 11: Protections Against Abnormal Conditions 40

SECTION 12: Troubleshooting Guide..... 42

SECTION 13: Specifications 46

SECTION 14: Warranty 48





SECTION 1 | Safety Instructions

IMPORTANT SAFETY INSTRUCTIONS

SAVE THESE INSTRUCTIONS

This manual contains important Safety and Operating Instructions. Please read before using this unit.

The following safety symbols will be used in this manual to highlight safety and information:



WARNING!

Indicates possibility of physical harm to the user in case of non-compliance.



CAUTION!

Indicates possibility of damage to the equipment in case of non-compliance.

GENERAL SAFETY

Installation and Wiring Compliance

INSTALLATION AND WIRING MUST COMPLY WITH THE LOCAL AND NATIONAL ELECTRICAL CODES AND MUST BE DONE BY A CERTIFIED ELECTRICIAN.

Preventing Electrical Shock

- Always connect the grounding connection on the inverter to the appropriate grounding system
- Disassembly / repair should be carried out by qualified personnel only
- Disconnect all AC and DC side connections before working on any circuits associated with the inverter. Turning the ON/OFF switch on the inverter to OFF position may not entirely remove dangerous voltages
- Be careful when touching bare terminals of capacitors. Capacitors may retain high lethal voltages even after the power has been removed. Discharge the capacitors before working on the circuits

Installation Environment

- The inverter should be installed indoor only in a well ventilated, cool, dry environment
- Do not expose to moisture, rain, snow or liquids of any type
- To reduce the risk of overheating and fire, do not obstruct the intake and discharge openings of the cooling fans
- To ensure proper ventilation, do not install in a low clearance compartment



SECTION 1 | Safety Instructions

Preventing Fire and Explosion Hazards

- Working with the inverter may produce arcs or sparks. Thus, the inverter should not be used in areas where there are inflammable materials or gases requiring ignition protected equipment.
- These areas may include spaces containing gasoline powered machinery, fuel tanks, battery compartments

Precautions when Working with Batteries.

- Batteries contain very corrosive diluted Sulphuric Acid as electrolyte. Precautions should be taken to prevent contact with skin, eyes or clothing.
- Batteries generate Hydrogen and Oxygen during charging resulting in evolution of explosive gas mixture. Care should be taken to ventilate the battery area and follow the battery manufacturer's recommendations.
- Never smoke or allow a spark or flame near the batteries.
- Use caution to reduce the risk of dropping a metal tool on the battery. It could spark or short circuit the battery or other electrical parts and could cause an explosion.
- Remove metal items like rings, bracelets and watches when working with batteries. Batteries can produce short circuit current high enough to weld a ring or the like to metal and thus, cause a severe burn.
- If you need to remove a battery, always remove the Negative terminal from the battery first. Make sure that all the accessories are off so that you do not cause a spark.

INVERTER SAFETY

Preventing Paralleling of the AC Output

The AC output of this inverter cannot be synchronised with another AC source and hence, it is not suitable for paralleling. The AC output of the inverter should never be connected directly to an electrical breaker panel / load center which is also fed from the utility power / generator. Such a connection may result in parallel operation of the different power sources and AC power from the utility / generator will be fed back into the inverter which will instantly damage the output section of the inverter and may also pose a fire and safety hazard. If an electrical breaker panel / load center is fed from an inverter and this panel is also required to be powered from additional alternate AC sources, the AC power from all the AC sources like the utility / generator / inverter should first be fed to a manual selector switch and the output of the selector switch should be connected to the electrical breaker panel / load center. Appropriate Automatic Transfer Switch like Samlex America Model STS-30 may also be used.

To prevent possibility of paralleling and severe damage to the inverter, never use a simple jumper cable with a male plug on both ends to connect the AC output of the inverter to a handy wall receptacle in the home / RV.





SECTION 1 | Safety Instructions

Connecting to Multi-Wire Branch Circuits

Do not directly connect the Hot side of the 120 VAC of the inverter to the two Hot legs of the 120 / 240 VAC electrical breaker panel / load centre where multi-wire (common Neutral) branch circuit wiring method is used for distribution of AC power. This may lead to overloading / overheating of the Neutral conductor and is a risk of fire.

A split phase transformer (isolated or auto-transformer) of suitable wattage rating (25% more than the wattage rating of the inverter) with primary of 120 VAC and secondary of 120 / 240 VAC (Two 120 VAC split phases 180 degrees apart) should be used. The Hot and Neutral of the 120 VAC output of the inverter should be fed to the primary of this transformer and the 2 Hot outputs (120 VAC split phases) and the Neutral from the secondary of this transformer should be connected to the electrical breaker panel / load centre.

Preventing Input Over Voltage

It is to be ensured that the input voltage of the inverter does not exceed 16.5 VDC to prevent permanent damage to the inverter. Please observe the following precautions:

- Ensure that the maximum charging voltage of the battery charger / alternator / solar charge controller is below 16.5 VDC.
- Do not use unregulated solar panels to charge a battery. Under cold ambient temperatures, the output of the solar panel may exceed 16.5 VDC. Always use a charge controller between the solar panel and the battery.
- Do not connect a 12 VDC input inverter to a battery system with a voltage higher than 12 VDC nominal.

Preventing Reverse Polarity on the Input Side

When making battery connection on the input side, make sure that the polarity of battery connection is correct (Connect the Positive of the battery to the Positive terminal of the inverter and the Negative of the battery to the Negative terminal of the inverter). If the input is connected in reverse polarity, fuse(s) on the DC input side will blow and may also cause permanent damage to the inverter.



SECTION 2 | General Information on Inverters

INVERTER GENERAL INFORMATION

Why an Inverter is Needed

The utility grid supplies you with alternating current (AC) electricity. AC is the standard form of electricity for anything that “plugs in” to the utility power. Direct current (DC) electricity flows in a single direction. Batteries provide DC electricity. AC alternates its direction many times per second. AC is used for grid service because it is more practical for long distance transmission. For more details read “Characteristics of Sinusoidal AC Power” on page 9.

An inverter converts DC to AC, and also changes the voltage. In other words, it is a power adapter. It allows a battery-based system to run conventional AC appliances directly or through conventional home wiring. There are ways to use DC directly, but for a modern lifestyle, you will need an inverter for the vast majority, if not all of your loads (in electrical terms, “loads” are devices that use electrical energy).

Incidentally, there is another type of inverter called grid-interactive. It is used to feed solar (or other renewable) energy into a grid-connected home and to feed excess energy back into the utility grid. This inverter is NOT grid interactive.

Inverter Should Meet the Application

To choose an inverter; you should first define your needs. Where is the inverter to be used? Inverters are available for use in buildings (including homes), for recreational vehicles, boats, and portable applications. Will it be connected to the utility grid in some way? Electrical conventions and safety standards differ for various applications, so don't improvise.

Electrical Standards

The DC input voltage must conform to that of the electrical system and battery bank. 12 volts is recommended for small, simple systems. 24 and 48 volts are the common standards for higher capacities. A higher voltage system carries less current, which makes the system wiring cheaper and easier.

The inverter's AC output must conform to the conventional power in the region in order to run locally available appliances. The standard for AC utility service in North America is 120 and 240 Volts at a frequency of 60 Hertz (cycles per second). In Europe, South America, and most other places, it is 230 volts at 50 Hertz.

Power Capacity – “Continuous” and “Surge”

How much load can an inverter handle? Its power output is rated in Watts. Read details under “Characteristics of Sinusoidal AC Power” on page 9. There are two levels of power rating: “continuous” rating and a “surge” rating. Continuous means the amount of power the inverter can handle for a minimum of 3 hours. When an inverter is rated at a certain number of Watts, that number generally refers to its continuous rating. The “surge power” indicates the power to handle instantaneous overload of short duration to provide higher power required to start certain type of devices and appliances.





SECTION 2 | General Information on Inverters

Loads that Require “Surge Power” to Start

Resistive types of loads (like incandescent lamps, toaster, coffee maker, electric range, iron etc) do not require extra power to start. Their starting power is the same as their running power. Some loads like induction motors and high inertia motor driven devices will initially require a very large starting or “surge” power to start from rest. Once they have started moving and have attained their rated speed, their power requirement reduces to their normal running power. The surge may last up to 5 seconds. TVs and microwave ovens also require surge power for starting. The manufacturers’ specification of the appliances and devices indicates only the running power required. The surge power required has to be guessed at best. See below under “Sizing of inverter for loads that require starting surge.”

If an inverter cannot efficiently feed the surge power, it may simply shut down instead of starting the device. If the inverter’s surge capacity is marginal, its output voltage will dip during the surge. This can cause a dimming of the lights in the house, and will sometimes crash a computer.

Any weakness in the battery and cabling to the inverter will further limit its ability to start a motor. A battery bank that is undersized, in poor condition, or has corroded connections, can be a weak link in the power chain. The inverter cables and the battery interconnect cables must be sized properly. The spike of DC current through these cables is many hundreds of amps at the instant of motor starting. Please follow the instructions under “Installation - DC Side Connections” on page 25.

Sizing of Inverter for Loads that Require Starting Surge

Observe the following guideline to determine the continuous wattage of the inverter for powering loads that require starting surge. (Multiply the running watts of the device / appliance by the surge factor). **NOTE: The surge power rating specified for the inverter is valid for duration of less than 2 seconds. This very short duration may not be sufficient to start motor based loads which may require up to 5 seconds to complete the starting process. Hence, for purposes of sizing the inverter, use only the continuous power rating of the inverter.**

Type of Device or Appliance	Surge Factor for Determining Continuous Wattage of the Inverter (No. of times the running power rating of the device/appliance)
Refrigerator / Freezer	5
Air Compressors	4
Dishwasher	3
Automatic Washer	3
Sump pump	3
Furnace fans	3
Industrial motors	3
Portable kerosene / diesel fuel heater	2
Circular saw / Bench Grinder	3
Incandescent / Halogen / Quartz Lamp	3





SECTION 2 | General Information on Inverters

Power Rating of Microwaves

The power rating of the microwave oven specifies its output or cooking power in Watts. Microwaves are not very efficient devices – efficiency is around 50%. Therefore, its input power is almost 2x its output / cooking power. Hence, Watt rating of the inverter should be at least 2x the Watt rating of the microwave oven.

Powering a Water Supply Pump

A water well or pressure pump often places the greatest demand on the inverter. It warrants special consideration. Most pumps draw a very high surge of current during start up. The inverter must have sufficient surge capacity to handle it while running any other loads that may be ON. It is important to size an inverter sufficiently, especially to handle the starting surge (If the exact starting rating is not available, the starting surge can be taken as 3 times the normal running rating of the pump). Oversize it still further if you want it to start the pump without causing lights to dim or blink.

In North America, most pumps (especially submersibles) run on 240 VAC, while smaller appliances and lights use 120 VAC. To obtain 240 VAC from a 120 VAC inverter, use a 120 VAC to 240 VAC transformer. If you do not already have a pump installed, you can get a 120 volt pump if you don't need more than 1/2 HP.

Idle Power

Idle power is the consumption of the inverter when it is ON, but no loads are running. It is “wasted” power, so if you expect the inverter to be ON for many hours during which there is very little load (as in most residential situations), you want this to be as low as possible.

Phantom and Idling Loads

Most of the modern gadgets draw some power whenever they are plugged in. Some of them use power to do nothing at all. An example is a TV with a remote control. Its electric eye system is ON day and night, watching for your signal to turn the screen ON. Every appliance with an external wall-plug transformer uses power even when the appliance is turned OFF. These little loads are called “phantom loads” because their power draw is unexpected, unseen, and easily forgotten.

A similar concern is “idling loads.” These are devices that must be ON all the time in order to function when needed. These include smoke detectors, alarm systems, motion detector lights, fax machines, and answering machines. Central heating systems have a transformer in their thermostat circuit that stays ON all the time. Cordless (rechargeable) appliances draw power even after their batteries reach a full charge. If in doubt, feel the device. If it's warm, that indicates wasted energy.





SECTION 3 | Characteristics of Sinusoidal AC Power

VOLTAGE, CURRENT, POWER FACTOR, TYPES OF LOADS

The voltage waveform of 120 VAC, 60 Hz mains / utility power is like a sine wave (see Fig 8.1, page 30). In a voltage with a sine wave-form, the instantaneous value and polarity of the voltage varies with respect to time and the wave-form is like a sine wave. In one cycle, it slowly rises in the Positive direction from 0V to a peak Positive value + $V_{peak} = 170V$, slowly drops to 0V, changes the polarity to Negative direction and slowly increases in the Negative direction to a peak Negative value - $V_{peak} = 170V$ and then slowly drops back to 0V. There are 60 such cycles in 1 sec. Cycles per second is called the "frequency" and is also termed "Hertz (Hz)". If a linear load is connected to this type of voltage, the load will draw current which will also have the same sine wave-form. However, the peak value of the current will depend upon the impedance of the load. Also, the phase of the sine wave-form of the current drawn by the linear load may be the same or lead / lag the phase of sine wave-form of the voltage. This phase difference determines the "Power Factor (mathematically = the Cosine of the phase difference)" of the load. In a resistive type of load (like incandescent lamps, heaters etc) the sine wave-form of the current drawn by the load has 0 phase difference with the sine wave-form of the voltage of the AC power source. The Power Factor of a resistive load is unity (1). The rated output power (in Watts) of the inverters is normally specified for resistive type of loads that have unity (1) Power Factor. In a reactive type of load (like electric motor driven loads, fluorescent lights, computers, audio / video equipment etc), the phase of the sine wave-form of the current drawn by the load may lead or lag the sine wave-form of the AC voltage source. In this case, the Power Factor of reactive loads is lower than unity (1) – generally between 0.8 and 0.6. A reactive load reduces the effective wattage that can be delivered by an AC power source.

RMS AND PEAK VALUES

As explained above, in a sine wave (Fig 8.1, page 30), the instantaneous values of AC voltage (Volt, V) and current (Ampere, A) vary with time. Two values are commonly used – Root Mean Square (RMS) value and peak value. For simplicity, RMS value can be considered as an average value. Mathematically, Peak Value = $1.414 \times \text{RMS}$ value. For example, the 120 VAC, 60Hz mains / utility power is the RMS value. The peak value corresponding to this is = $1.414 \times 120 = 170V$. **The values of the rated output voltage and current of an AC power source are their RMS values.**

AC POWER – WATTS / VA

- The power rating of an AC power source is designated in Volt Amperes (VA) or in Watts (W)
- Power in Volt Amperes (VA) = RMS Volts (V) x RMS Amps (A)
- Power in Watts = RMS Volts (V) x RMS Amps (A) x Power Factor

NOTE: The rated power of the inverter in Watts (W) is normally designated for a linear, resistive type of load that draws linear current at unity (1) Power Factor. If the load is linear and reactive type, the rated power of the inverter in watts will be limited to its normal rated power in watts (W) x Power Factor. For example, an inverter rated for 1000W (at unity Power Factor) will be able to deliver only 600W to a reactive type of load with a Power Factor of 0.6.





SECTION 4 | AC Power Distribution & Grounding



CAUTION!

PLEASE NOTE THAT THE AC OUTPUT CONNECTIONS AND THE DC INPUT CONNECTIONS ON THESE INVERTERS ARE NOT CONNECTED (BONDED) TO THE METAL CHASSIS OF THE INVERTER. BOTH THE INPUT AND OUTPUT CONNECTIONS ARE ISOLATED FROM THE METAL CHASSIS AND FROM EACH OTHER. SYSTEM GROUNDING, AS REQUIRED BY NATIONAL / LOCAL ELECTRICAL CODES / STANDARDS, IS THE RESPONSIBILITY OF THE USER / SYSTEM INSTALLER.

CONDUCTORS FOR ELECTRICAL POWER DISTRIBUTION

For single phase transmission of AC power or DC power, two conductors are required that will be carrying the current. These are called the “current-carrying” conductors. A third conductor is used for grounding to prevent the build up of voltages that may result in undue hazards to the connected equipment or persons. This is called the “non current-carrying” conductor (will carry current only under ground fault conditions).

GROUNDING TERMINOLOGY

The term “grounded” – indicates that one or more parts of the electrical system are connected to earth, which is considered to have zero voltage or potential. In some areas, the term “earthing” is used instead of grounding.

A “grounded conductor” – is a “current-carrying” conductor that normally carries current and is also connected to earth. Examples are the “Neutral” conductor in AC wiring and the Negative conductor in many DC systems. A “grounded system” is a system in which one of the current-carrying conductors is grounded.

An “equipment grounding conductor” – is a conductor that does not normally carry current (except under fault conditions) and is also connected to earth. It is used to connect the exposed metal surfaces of electrical equipment together and then to ground. Examples are the bare copper conductor in non-metallic sheathed cable (Romex®) and the Green, insulated conductor in power cords in portable equipment. These equipment-grounding conductors help to prevent electric shock and allow over-current devices to operate properly when ground faults occur. The size of this conductor should be coordinated with the size of the over-current devices involved.

A “grounding electrode” – is the metallic device that is used to make actual contact with the earth. Other types of grounding electrodes include metal water pipes and metal building frames.

A “grounding electrode conductor” – is the conductor between a common single grounding point in the system and the grounding electrode.

“Bond” – refers to the connection between the “grounded conductor”, the “equipment grounding” conductors and the “grounding electrode” conductor. Bonding is also used to describe connecting all of the exposed metal surfaces together to complete the equipment- grounding conductors.





SECTION 4 | AC Power Distribution & Grounding

GROUNDING ELECTRICAL POWER DISTRIBUTION SYSTEM

The National Electrical Code (NEC) requires the use of a "grounded electrical distribution system". As per this system, one of the two current-carrying conductors is required to be grounded. This grounded conductor is called the "Neutral/Cold/Return". As this conductor is bonded to earth ground, it will be at near zero voltage or potential. There is no risk of electrical shock if this conductor is touched. The other current carrying conductor is called the "Line/Live/Hot". The connection between the "Neutral" and the grounding electrode conductor is made only at one point in the system. This is known as the "system ground". This single point connection (bond) is usually made in the service entrance or the load center. If this connection is inadvertently made in more than one place, then unwanted currents will flow in the equipment grounding conductors. These unwanted currents may cause inverters and charge controllers to be unreliable and may interfere with the operation of ground-fault detectors and over-current devices.

NOTE: A current-carrying conductor that is not bonded to the earth ground cannot be called a "Neutral". This conductor will be at an elevated voltage with respect to the earth ground and may produce electrical shock when touched.

POLARITY AND COLOR CODES FOR POWER CORDS AND PLUGS FOR AC DEVICES AND APPLIANCES

Single phase 120 VAC, 60 Hz AC devices and appliances use 2 pole, 3 wire grounding configuration for connection to the AC power source. The plug of the power cord has three pins – two flat pins (also called poles) that are connected to the two current-carrying conductors and a round pin which is connected to a non-current carrying conductor (this will carry current only during ground fault conditions). One flat pin is connected to a black current-carrying conductor which is also called "Line/Live/Hot" pole. The other flat pin is connected to the white current-carrying conductor also called the "Neutral/Return/ Cold" pole. The third round pin is connected to the non-current carrying GREEN "equipment grounding conductor". This GREEN "equipment grounding conductor" is bonded to the metal chassis of the device or appliance.

AC OUTPUT CONNECTIONS - PSE-12125A / PSE-12175A

The 120 VAC, 60 Hz version of these inverters use NEMA 5-15R receptacles (f, Fig. 7.1) for connecting the AC output of the inverter to devices and appliances fitted with a NEMA 5-15P plug. The two rectangular slots are connected to the current-carrying conductors of the AC power source inside the inverter. The round slot is the "equipment grounding" connection and is internally connected to the metal chassis of the inverter.



CAUTION!

For the 120 VAC, 60 Hz NEMA 5-15R receptacles in PSE-12125A and PSE-12175A (f, Fig. 7.1), the current carrying conductor connected to the longer rectangular slot is isolated from the metal chassis of the inverter. Hence, when the metal chassis of the inverter is connected to the earth ground, the longer rectangular slot is not grounded to the earth ground. The longer rectangular slot is, therefore, not a "Neutral". Do not touch this slot as it will be at an elevated voltage with respect to the metal chassis / earth ground and may produce an electrical shock when touched.





SECTION 4 | AC Power Distribution & Grounding

AC OUTPUT CONNECTIONS - PSE-12275A

The AC output connections (n, Fig. 7.2) of inverter model PSE-12275A have three insulated conductors – one BLACK and one WHITE for carrying current and one GREEN for “equipment grounding”. The GREEN color “equipment grounding” conductor is connected to the metal chassis of the inverter. These three conductors exit through a pocket (n, Fig. 7.2) in the front side of the inverter. These three conductors are used for hard-wiring the inverter to a breaker panel. For drawing the full 2750W of power of the inverter, the output conductors should be hard wired to a suitable breaker panel.

PSE-12275A is also provided with a separate plate (o, Fig. 7.2) which has a NEMA 5-15R receptacle (f) wired through a 15A breaker (p). This plate with the receptacle and breaker fits over the pocket (n, Fig. 7.2) through which the output conductors exit the inverter. The NEMA 5-15R receptacle (f) can be connected to the three output conductors if the AC power output is required to be drawn from the front panel of the inverter. **Please note that the NEMA 5-15R receptacle is wired through a 15A breaker and hence, the power delivered from this receptacle will be limited to 1500 watts only.**



CAUTION!

The White current carrying conductor is NOT bonded to the metal chassis of the inverter. Hence, when the metal chassis of the inverter is connected to the earth ground, this White current carrying conductor will not be grounded to the earth ground. The white conductor is, therefore, NOT a “Neutral”. Do not touch this conductor as it will be at an elevated voltage with respect to the metal chassis / earth ground and may produce electrical shock!

GROUNDING OF PSE-12125A / PSE-12175A TO EARTH OR TO OTHER DESIGNATED GROUND

For safety, the metal chassis of the inverter is required to be grounded to the earth ground or to the other designated ground (For example, in a mobile RV, the metal frame of the RV is normally designated as the Negative DC ground). An equipment grounding bolt with a wing nut has been provided for grounding the metal chassis of the inverter to the appropriate ground.

When using the inverter in a building, connect a #8 AWG insulated stranded copper wire from the above equipment grounding bolt to the earth ground connection (a connection that connects to the ground rod or to the water pipe or to another connection that is solidly bonded to the earth ground). The connections must be tight against bare metal. Use star washers to penetrate paint and corrosion.

When using the inverter in a mobile RV, connect a #8 AWG insulated stranded copper wire from the above equipment grounding bolt to the appropriate ground bus of the RV (usually the vehicle chassis or a dedicated DC ground bus). The connections must be tight against bare metal. Use star washers to penetrate paint and corrosion.





SECTION 4 | AC Power Distribution & Grounding

GROUNDING OF PSE-12275A TO EARTH OR TO OTHER DESIGNATED GROUND

In case of hard wiring of the PSE-12275A inverter to a building's service entrance /electrical breaker panel / load center, proper grounding and bonding have to be undertaken as per the applicable national / local electrical codes. In such cases, the electrical installation should be undertaken by a qualified electrician.

When using PSE-12275A independently by connecting the provided plate with NEMA 5-15R receptacle and breaker to their front panel, it should be grounded as in the case of PSE-12125A and PSE-12175A i.e. connect an AWG #8 insulated stranded copper wire from the equipment grounding bolt to the earth ground connection (a connection that connects to the ground rod or to the water pipe or to another connection that is solidly bonded to the earth ground). The connections must be tight against bare metal. Use star washers to penetrate paint and corrosion.

When using PSE-12275A in a mobile RV, connect a #8 AWG insulated stranded copper wire from the equipment grounding bolt to the appropriate ground bus of the RV (usually the vehicle chassis or a dedicated DC ground bus). The connections must be tight against bare metal. Use star washers to penetrate paint and corrosion.





SECTION 5 | Limiting Electro-magnetic Interference (EMI)

The inverter contains internal switching devices which generate conducted and radiated electromagnetic interference (EMI). The EMI is more pronounced in inverters whose output voltage has modified sine wave form as modified sine wave form is composed of odd harmonics of the fundamental frequency (60 Hz). These harmonics may produce buzzing sound in inexpensive stereo systems because the power supply of these systems does not provide adequate filtration. In such cases, use stereo systems with better quality power supply.

The magnitude of EMI is limited to acceptable levels by circuit design, but cannot be entirely eliminated. The effects of EMI will also depend upon a number of factors external to the power supply, like proximity of the inverter to the EMI receptors, types and quality of connecting wires and cables, etc. EMI due to factors external to the inverter can be reduced as follows:

- Ensure the inverter is firmly Grounded to the ground system of the building or vehicle.
- Locate the inverter as far away from EMI receptors like radio, audio and video devices as possible.
- Keep the DC side cables between the battery and the inverter as short as possible.
- Twist the DC side cables. This will partially cancel out the radiated noise from the cables.
- Shield the DC side cables with metal sheathing / copper foil / braiding.
- Use co-axial shielded cable for all antenna inputs (instead of 300 ohm twin leads).
- Use high quality, shielded cables to attach audio and video devices to one another.
- Do not operate other high power loads when operating audio / video equipment.



SECTION 6 | General Information on Lead Acid Batteries

Lead-acid batteries can be categorized by the type of application:

1. Automotive service - Starting/Lighting/Ignition (SLI, a.k.a. cranking), and
2. Deep cycle service.

Deep Cycle Lead Acid Batteries of appropriate capacity are recommended for powering of inverters.

Deep Cycle Lead Acid Batteries

Deep cycle batteries are designed with thick-plate electrodes to serve as primary power sources, to have a constant discharge rate, to have the capability to be deeply discharged up to 80 % capacity and to repeatedly accept recharging. They are marketed for use in recreation vehicles (RV), boats and electric golf carts – so they may be referred to as RV batteries, marine batteries or golf cart batteries. Use Deep Cycle batteries for powering these inverters.

Rated Capacity Specified in Ampere-hour (Ah)

Battery capacity "C" is specified in Ampere-hours (Ah). An Ampere is the unit of measurement for electrical current and is defined as a Coulomb of charge passing through an electrical conductor in one second. The Capacity "C" in Ah relates to the ability of the battery to provide a constant specified value of discharge current (also called "C-Rate" - see page 16) over a specified time in hours before the battery reaches a specified discharged terminal voltage (Also called "End Point Voltage") at a specified temperature of the electrolyte. As a benchmark, the automotive battery industry rates batteries at a discharge current or C-Rate of C/20 Amperes corresponding to 20 Hour discharge period. The rated capacity "C" in Ah in this case will be the number of Amperes of current the battery can deliver for 20 Hours at 80°F (26.7°C) till the voltage drops to 1.75V / Cell. i.e. 10.5V for 12V battery, 21V for 24V battery and 42V for a 48V battery. For example, a 100 Ah battery will deliver 5A for 20 Hours.

Rated Capacity Specified in Reserve Capacity (RC)

Battery capacity may also be expressed as Reserve Capacity (RC) in minutes typically for automotive SLI (Starting, Lighting and Ignition) batteries. It is the time in minutes a vehicle can be driven after the charging system fails. This is roughly equivalent to the conditions after the alternator fails while the vehicle is being driven at night with the headlights on. The battery alone must supply current to the headlights and the computer/ignition system. The assumed battery load is a constant discharge current of 25A. Reserve capacity is the time in minutes for which the battery can deliver 25 Amperes at 80°F (26.7°C) till the voltage drops to 1.75V / Cell i.e. 10.5V for 12V battery, 21V for 24V battery and 42V for 48V battery.

Approximate relationship between the two units is:

$$\text{Capacity "C" in Ah} = \text{Reserve Capacity in RC minutes} \times 0.6$$





SECTION 6 | General Information on Lead Acid Batteries

Typical Battery Sizes

Table 6.1 below shows details of some popular battery sizes:

TABLE 6.1: POPULAR BATTERY SIZES		
BCI* Group	Battery Voltage, V	Battery Capacity, Ah
27 / 31	12	105
4D	12	160
8D	12	225
GC2**	6	220

* Battery Council International; ** Golf Cart

Specifying Charging / Discharging Currents: C-Rate

Electrical energy is stored in a cell / battery in the form of DC power. The value of the stored energy is related to the amount of the active materials pasted on the battery plates, the surface area of the plates and the amount of electrolyte covering the plates. As explained above, the amount of stored electrical energy is also called the Capacity of the battery and is designated by the symbol "C".

The time in Hours over which the battery is discharged to the "End Point Voltage" for purposes of specifying Ah capacity depends upon the type of application. Let us denote this discharge time in hours by "T". Let us denote the discharge current of the battery as the "C-Rate". If the battery delivers a very high discharge current, the battery will be discharged to the "End Point Voltage" in a shorter period of time. On the other hand, if the battery delivers a lower discharge current, the battery will be discharged to the "End Point Voltage" after a longer period of time. Mathematically:

EQUATION 1:

$$\text{Discharge current "C-Rate"} = \text{Capacity "C" in Ah} \div \text{Discharge Time "T"}$$





SECTION 6 | General Information on Lead Acid Batteries

Table 6.2 below gives some examples of C-Rate specifications and applications:

TABLE 6.2: DISCHARGE CURRENT RATES - "C-RATES"		
Hours of discharge time "T" till the "End Point Voltage"	"C-Rate" Discharge Current in Amps = Capacity "C" in Ah ÷ Discharge Time "T" in Hrs.	Example of C-Rate Discharge Currents for 100 Ah battery
0.5 Hrs.	2C	200A
1 Hrs.	1C	100A
5 Hrs. (Inverter application)	C/5 or 0.2C	20A
8 Hrs. (UPS application)	C/8 or 0.125C	12.5A
10 Hrs. (Telecom application)	C/10 or 0.1C	10A
20 Hrs. (Automotive application)	C/20 or 0.05C	5A
100 Hrs.	C/100 or 0.01C	1A

NOTE: When a battery is discharged over a shorter time, its specified "C-Rate" discharge current will be higher. For example, the "C-Rate" discharge current at 5 Hour discharge period i.e. C/5 Amps will be 4 times higher than the "C-Rate" discharge current at 20 Hour discharge period i.e. C/20 Amps.

Charging / Discharging Curves

Fig. 6.1 (page 18) shows the charging and discharging characteristics of a typical 12V / 24V Lead Acid battery at electrolyte temperature of 80°F / 26.7°C. The curves show the % State of Charge (X-axis) versus terminal voltage (Y-axis) during charging and discharging at different C-Rates. **Please note that X-axis shows % State of Charge. State of Discharge will be = 100% - % State of Charge.** These curves will be referred to in the subsequent explanations.

Reduction in Usable Capacity at Higher Discharge Rates – Typical in Inverter Application

As stated above, the capacity of automotive battery is normally applicable at a discharge rate of 20 Hours. As the discharge rate is increased as in cases where the inverters are driving higher capacity loads, the usable capacity reduces due to "Peukert Effect". This relationship is not linear but is more or less according to the Table 6.3 (page 18).



SECTION 6 | General Information on Lead Acid Batteries

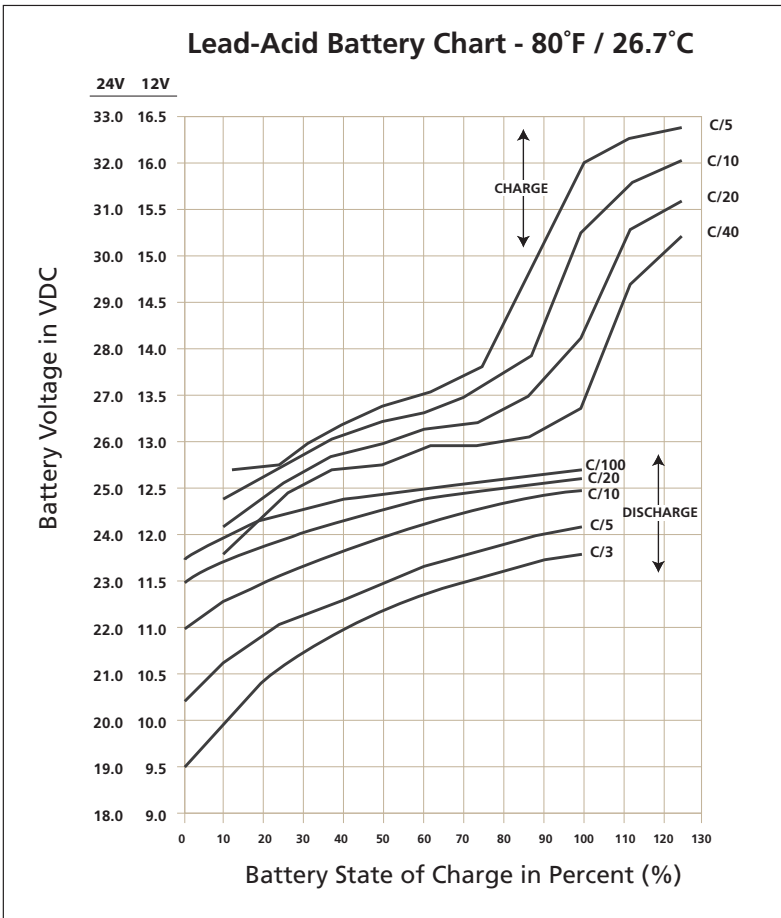

Fig. 6.1: Charging / Discharging Curves for Typical Lead Acid Battery

TABLE 6.3 BATTERY CAPACITY VERSUS RATE OF DISCHARGE – C-RATE	
C-Rate Discharge Current	Usable Capacity (%)
C/20	100%
C/10	87%
C/8	83%
C/6	75%
C/5	70%
C/3	60%
C/2	50%
1C	40%



SECTION 6 | General Information on Lead Acid Batteries

Table 6.3 (page 18) shows that a 100 Ah capacity battery will deliver 100% (i.e. full 100 Ah) capacity if it is slowly discharged over 20 Hours at the rate of 5 Amperes (50W output for a 12V inverter and 100W output for a 24V inverter). However, if it is discharged at a rate of 50 Amperes (500W output for a 12V inverter and 1000W output for a 24V inverter) then theoretically, it should provide $100 \text{ Ah} \div 50 = 2$ Hours. However, the Table above shows that for 2 Hours discharge rate, the capacity is reduced to 50% i.e. 50 Ah. Therefore, at 50 Ampere discharge rate (500W output for a 12V inverter and 1000W output for a 24V inverter) the battery will actually last for $50 \text{ Ah} \div 50 \text{ Amperes} = 1$ Hour.

State of Charge (SOC) of a Battery – Based on “Standing Voltage”

The “Standing Voltage” of a battery under open circuit conditions (no load connected to it) can approximately indicate the State of Charge (SOC) of the battery. The “Standing Voltage” is measured after disconnecting any charging device(s) and the battery load(s) and letting the battery “stand” idle for 3 to 8 hours before the voltage measurement is taken. Table 6.4 below shows the State of Charge versus Standing Voltage for a typical 12V/24V battery system at 80°F (26.7°C).

Percentage of Full Charge	Standing Voltage of Individual Cells	Standing Voltage of 12V Battery	Standing Voltage of 24V Battery
100%	2.105V	12.63V	25.26V
90%	2.10V	12.6V	25.20V
80%	2.08V	12.5V	25.00V
70%	2.05V	12.3V	24.60V
60%	2.03V	12.2V	24.40V
50%	2.02V	12.1V	24.20V
40%	2.00V	12.0V	24.00V
30%	1.97V	11.8V	23.60V
20%	1.95V	11.7V	23.40V
10%	1.93V	11.6V	23.20V
0%	= / < 1.93V	= / < 11.6V	= / < 23.20V

Check the individual cell voltages / specific gravity. If the inter cell voltage difference is more than a 0.2V, or the specific gravity difference is 0.015 or more, the cells will require equalization. **Please note that only the non-sealed / vented / flooded / wet cell batteries are equalized. Do not equalize sealed / VRLA type of AGM or Gel Cell Batteries.**

State of Discharge of a loaded battery – Low Battery / DC Input Voltage Alarm and Shutdown in Inverters

Most inverter hardware estimate the State of Discharge of the loaded battery by measuring the voltage at the inverter’s DC input terminals (considering that the DC input cables are thick enough to allow a negligible voltage drop between the battery and the inverter) .





SECTION 6 | General Information on Lead Acid Batteries

Inverters are provided with a buzzer alarm to warn that the loaded battery has been deeply discharged to around 80% of the rated capacity. **Normally, the buzzer alarm is triggered when the voltage at the DC input terminals of the inverter has dropped to around 10.5V for a 12V battery or 21V for 24V battery at C-Rate discharge current of C/5 Amps and electrolyte temp. of 80°F.** The inverter is shut down if the terminal voltage at C/5 discharge current falls further to 10V for 12V battery (20V for 24V battery).

The State of Discharge of a battery is estimated based on the measured terminal voltage of the battery. The terminal voltage of the battery is dependent upon the following:

- **Temperature of the battery electrolyte:** Temperature of the electrolyte affects the electrochemical reactions inside the battery and produces a Negative Voltage Coefficient – during charging / discharging, the terminal voltage drops with rise in temperature and rises with drop in temperature
- **The amount of discharging current or “C-Rate”:** A battery has non linear internal resistance and hence, as the discharge current increases, the battery terminal voltage decreases non-linearly

The discharge curves in Fig. 6.1 (page 18) show the % State of Charge versus the terminal voltage of typical battery under different charge /discharge currents, i.e. “C-Rates” and fixed temperature of 80°F. (Please note that the X-Axis of the curves shows the % of State of Charge. The % of State of Discharge will be 100% - % State of Charge).

Low DC Input Voltage Alarm in Inverters

As stated earlier, the buzzer alarm is triggered when the voltage at the DC input terminals of the inverter has dropped to around 10.5V for a 12V battery (21V for 24V battery) at C-Rate discharge current of C/5 Amps. Please note that the terminal voltage relative to a particular of State Discharge decreases with the rise in the value of the discharge current. For example, terminal voltages for a State of Discharge of 80% (State of Charge of 20%) for various discharge currents will be as follows (Refer to Fig. 6.1, page 18):

Discharge Current: C-Rate	Terminal Voltage at 80% State of Discharge (20% SOC)		Terminal Voltage When Completely Discharged (0% SOC)	
	12V	24V	12V	24V
C/3 A	10.45V	20.9V	09.50V	19.0V
C/5 A	10.90V	21.8V	10.30V	20.6V
C/10 A	11.95V	23.9V	11.00V	22.0V
C/20 A	11.85V	23.7V	11.50V	23.0V
C/100 A	12.15V	24.3V	11.75V	23.5V





SECTION 6 | General Information on Lead Acid Batteries

In the example given above, the 10.5V / 21.0V Low Battery / DC Input Alarm would trigger at around 80% discharged state (20% SOC) when the C-Rate discharge current is C/5 Amps. However, for lower C-Rate discharge current of C/10 Amps and lower, the battery will be almost completely discharged when the alarm is sounded. **Hence, if the C-Rate discharge current is lower than C/5 Amps, the battery may have completely discharged by the time the Low DC Input Alarm is sounded.**

Low DC Input Voltage Shut-down in Inverters: As explained above, at around 80% State of Discharge of the battery at C-Rate discharge current of around C/5 Amps, the Low DC Input Voltage Alarm is sounded at around 10.5V for a 12V battery (at around 21V for 24V battery) to warn the user to disconnect the battery to prevent further draining of the battery. If the load is not disconnected at this stage, the batteries will be drained further to a lower voltage and to a completely discharged condition that is harmful for the battery and for the inverter.

Inverters are normally provided with a protection to shut down the output of the inverter if the DC voltage at the input terminals of the inverter drops below a threshold of around 10V for a 12V battery (20V for 24V battery). Referring to the Discharge Curves given in Fig 6.1 (page 18), the State of Discharge for various C-Rate discharge currents for battery voltage of 10V / 20V is as follows: (Please note that the X-Axis of the curves shows the % of State of Charge. The % of State of Discharge will be 100% - % State of Charge):

- 85% State of Discharge (15% State of Charge) at very high C-rate discharge current of C/3 Amps.
- 100% State of Discharge (0 % State of Charge) at high C-Rate discharge current of C/5 Amps.
- 100% discharged (0% State of charge) at lower C-rate Discharge current of C/10 Amps.

It is seen that at DC input voltage of 10V / 20V, the battery is completely discharged for C-rate discharge current of C/5 and lower.

In view of the above, it may be seen that a fixed Low DC Input Voltage Alarm is not useful. Temperature of the battery further complicates the situation. All the above analysis is based on battery electrolyte temperature of 80°F. The battery capacity varies with temperature. Battery capacity is also a function of age and charging history. Older batteries have lower capacity because of shedding of active materials, sulfation, corrosion, increasing number of charge / discharge cycles etc. Hence, the State of Discharge of a battery under load cannot be estimated accurately. However, the low DC input voltage alarm and shut-down function are designed to protect the inverter from excessive current drawn at the lower voltage.

Use of External Programmable Low Voltage Disconnects

The above ambiguity can be removed by using an external, programmable Low Voltage Disconnect where more exact voltage threshold can be set to disconnect the battery based on the actual application requirements.





SECTION 6 | General Information on Lead Acid Batteries

Please consider using the following Programmable Low Battery Cut-off / "Battery Guard" Models manufactured by Samlex America, Inc. www.samlexamerica.com

- BG-40 (40A) - For up to 400W, 12V inverter or 800W, 24V inverter
- BG-60 (60A) - For up to 600W, 12V inverter or 1200W, 24V inverter
- BG-200 (200A) - For up to 2000W, 12V inverter or 4000W, 24V inverter

Depth of Discharge of Battery and Battery Life

The more deeply a battery is discharged on each cycle, the shorter the battery life. Using more batteries than the minimum required will result in longer life for the battery bank. A typical cycle life chart is given in the Table 6.5 below:

Depth of Discharge % of Ah Capacity	Cycle Life of Group 27 /31	Cycle Life of Group 8D	Cycle Life of Group GC2
10	1000	1500	3800
50	320	480	1100
80	200	300	675
100	150	225	550

NOTE: It is recommended that the depth of discharge should be limited to 50%.

Series and Parallel Connection of Batteries

Series Connection

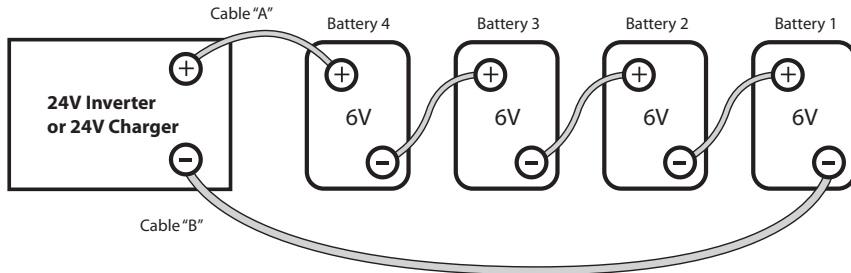

Fig 6.2: Series Connection

When two or more batteries are connected in series, their voltages add up but their Ah capacity remains the same. Fig. 6.2 above shows 4 pieces of 6V, 200 Ah batteries connected in series to form a battery bank of 24V with a capacity of 200 Ah. The Positive terminal of Battery 4 becomes the Positive terminal of the 24V bank. The Negative terminal of Battery 4 is connected to the Positive terminal of Battery 3. The Negative terminal of Battery 3 is connected to the Positive terminal of Battery 2. The Negative terminal of Battery 2 is connected to the Positive terminal of Battery 1.





SECTION 6 | General Information on Lead Acid Batteries

terminal of Battery 3 is connected to the Positive terminal of Battery 2. The Negative terminal of Battery 2 is connected to the Positive terminal of Battery 1. The Negative terminal of Battery 1 becomes the Negative terminal of the 24V battery bank.

Parallel Connection

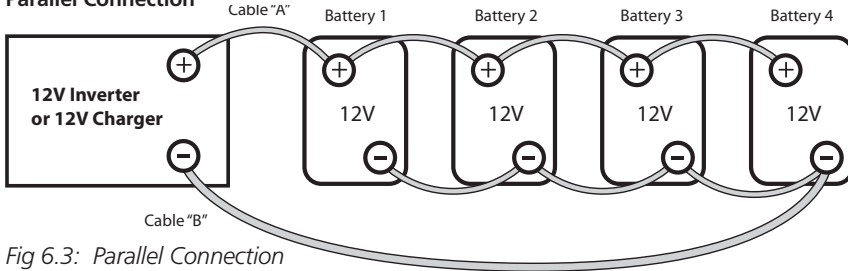

Fig 6.3: Parallel Connection

When two or more batteries are connected in parallel, their voltage remains the same but their Ah capacities add up. Fig. 6.3 above shows 4 pieces of 12V, 100 Ah batteries connected in parallel to form a battery bank of 12V with a capacity of 400 Ah. The four Positive terminals of Batteries 1 to 4 are paralleled (connected together) and this common Positive connection becomes the Positive terminal of the 12V bank. Similarly, the four Negative terminals of Batteries 1 to 4 are paralleled (connected together) and this common Negative connection becomes the Negative terminal of the 12V battery bank.

Series – Parallel Connection

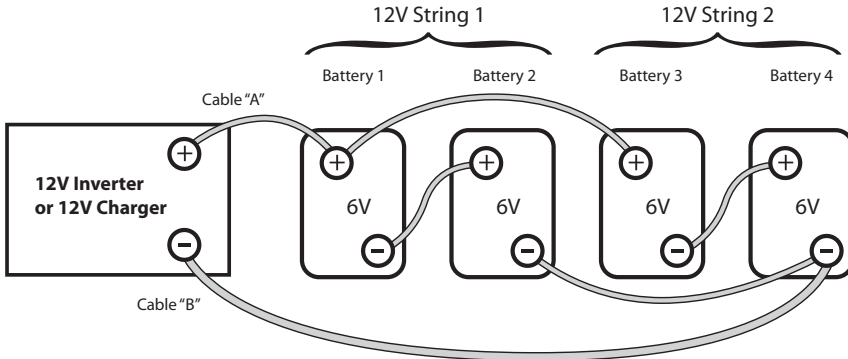

Fig. 6.4: Series-Parallel Connection

Figure 6.4 above shows a series – parallel connection consisting of four 6V, 200 AH batteries to form a 12V, 400 Ah battery bank. Two 6V, 200 Ah batteries, Batteries 1 and 2 are connected in series to form a 12V, 200 Ah battery (String 1). Similarly, two 6V, 200 Ah batteries, Batteries 3 and 4 are connected in series to form a 12V, 200 Ah battery (String 2). These two 12V, 200 Ah Strings 1 and 2 are connected in parallel to form a 12V, 400 Ah bank.





SECTION 6 | General Information on Lead Acid Batteries



CAUTION!

When 2 or more batteries / battery strings are connected in parallel and are then connected to an inverter or charger (See Figs 6.3 and 6.4 given above), attention should be paid to the manner in which the charger / inverter is connected to the battery bank. Please ensure that if the Positive output cable of the battery charger / inverter (Cable "A") is connected to the Positive battery post of the first battery (Battery 1 in Fig 6.3) or to the Positive battery post of the first battery string (Battery 1 of String 1 in Fig. 6.4), then the Negative output cable of the battery charger / inverter (Cable "B") should be connected to the Negative battery post of the last battery (Battery 4 as in Fig. 6.3) or to the Negative Post of the last battery string (Battery 4 of Battery String 2 as in Fig. 6.4). This connection ensures the following:

- The resistances of the interconnecting cables will be balanced.
- All the individual batteries / battery strings will see the same series resistance.
- All the individual batteries will charge / discharge at the same charging current and thus, will be charged to the same state at the same time.
- None of the batteries will see an overcharge condition.

Sizing the Inverter Battery Bank

One of the most frequently asked questions is, "how long will the batteries last?" This question cannot be answered without knowing the size of the battery system and the load on the inverter. Usually this question is turned around to ask "How long do you want your load to run?", and then specific calculation can be done to determine the proper battery bank size.

There are a few basic formulae and estimation rules that are used:

1. Active Power in Watts (W) = Voltage in Volts (V) x Current in Amperes (A) x Power Factor
2. For an inverter running from a 12V battery system, the DC current required from the 12V batteries is the AC power delivered by the inverter to the load in Watts (W) divided by 10 & for an inverter running from a 24V battery system, the DC current required from the 24V batteries is the AC power delivered by the inverter to the load in Watts (W) divided by 20.
3. Energy required from the battery = DC current to be delivered (A) x Time in Hours (H).



SECTION 6 | General Information on Lead Acid Batteries

The first step is to estimate the total AC watts (W) of load(s) and for how long the load(s) will operate in hours (H). The AC watts are normally indicated in the electrical nameplate for each appliance or equipment. In case AC watts (W) are not indicated, Formula 1 given above may be used to calculate the AC watts. The next step is to estimate the DC current in Amperes (A) from the AC watts as per Formula 2 above. An example of this calculation for a 12V inverter is given below:

Let us say that the total AC Watts delivered by the inverter = 1000W.

Then, using Formula 2 above, the DC current to be delivered by the 12V batteries = $1000W \div 10 = 100$ Amperes, or by 24V batteries = $1000W \div 20 = 50A$.

Next, the energy required by the load in Ampere Hours (Ah) is determined.

For example, if the load is to operate for 3 hours then as per Formula 3 above, the energy to be delivered by the 12V batteries = 100 Amperes \times 3 Hours = 300 Ampere Hours (Ah), or by the 24V batteries = $50A \times 3$ Hrs = 150 Ah.

Now, the capacity of the batteries is determined based on the run time and the usable capacity.

From Table 6.3 "Battery Capacity versus Rate of Discharge", the usable capacity at 3 Hour discharge rate is 60%. Hence, the actual capacity of the 12V batteries to deliver 300 Ah will be equal to: $300 \text{ Ah} \div 0.6 = 500$ Ah, and the actual capacity of the 24V battery to deliver 150 Ah will be equal to $150 \text{ Ah} \div 0.6 = 250$ Ah.

And finally, the actual desired rated capacity of the batteries is determined based on the fact that normally only 80% of the capacity will be available with respect to the rated capacity due to non availability of ideal and optimum operating and charging conditions. So the final requirements will be equal to:

FOR 12V BATTERY:

$500 \text{ Ah} \div 0.8 = 625$ Ah (note that the actual energy required by the load was 300 Ah).

FOR 24V BATTERY:

$250 \text{ Ah} \div 0.8 = 312.5$ Ah (Note that the actual energy required was 150 Ah).

It will be seen from the above that the final rated capacity of the batteries is almost 2 times the energy required by the load in Ah. **Thus, as a Rule of Thumb, the Ah capacity of the batteries should be twice the energy required by the load in Ah.**

CHARGING BATTERIES

The batteries can be charged by using good quality AC powered battery charger or from alternative energy sources like solar panels, wind or hydro systems. Make sure an appropriate battery charge controller is used. It is recommended that the batteries may be charged at 10% to 13% of the Ampere Hour capacity (20 hour discharge rate). Also, for complete charging (return of 100% capacity), it is recommended that a 3 stage charger may be used (Constant current bulk charging followed by constant voltage boost / absorption charging followed by constant voltage float charging).





SECTION 6 | General Information on Lead Acid Batteries

BATTERIES, ALTERNATORS AND ISOLATORS ON VEHICLES / RVS

It is recommended that for powering the inverter, one or more auxiliary deep cycle batteries should be used that are separate from the SLI batteries. The inverter should be powered from the deep cycle batteries. For charging the SLI and the auxiliary deep cycle batteries, the output from the alternator should be fed to these two sets of batteries through a battery isolator of appropriate capacity. The battery isolator is a solid state electronic circuit that will allow the alternator to charge the two sets of batteries when the engine is running. The isolator will allow the inverter to be operated from the auxiliary batteries and also prevent the SLI batteries from charging the auxiliary deep cycle batteries when the engine is not running. Battery isolators are available from auto / RV / marine parts suppliers.

A majority of smaller vehicles have 40 to 105 Ampere alternator and RVs have 100 to 130 Ampere alternator. When in use, the alternators heat up and their output current capacity can drop by up to 25%. When heated up, their charging voltage may also not reach the desired absorption voltage and will result in return of only about 80% of the battery capacity. In case the current output of the standard alternator is not adequate to charge the two sets of batteries rapidly and fully to 100% of their capacity, use heavy duty alternator that can produce higher current and voltage required to charge multiple battery systems. These alternators are available with auto / RV parts suppliers.





SECTION 7 | Layout, Controls & Indications

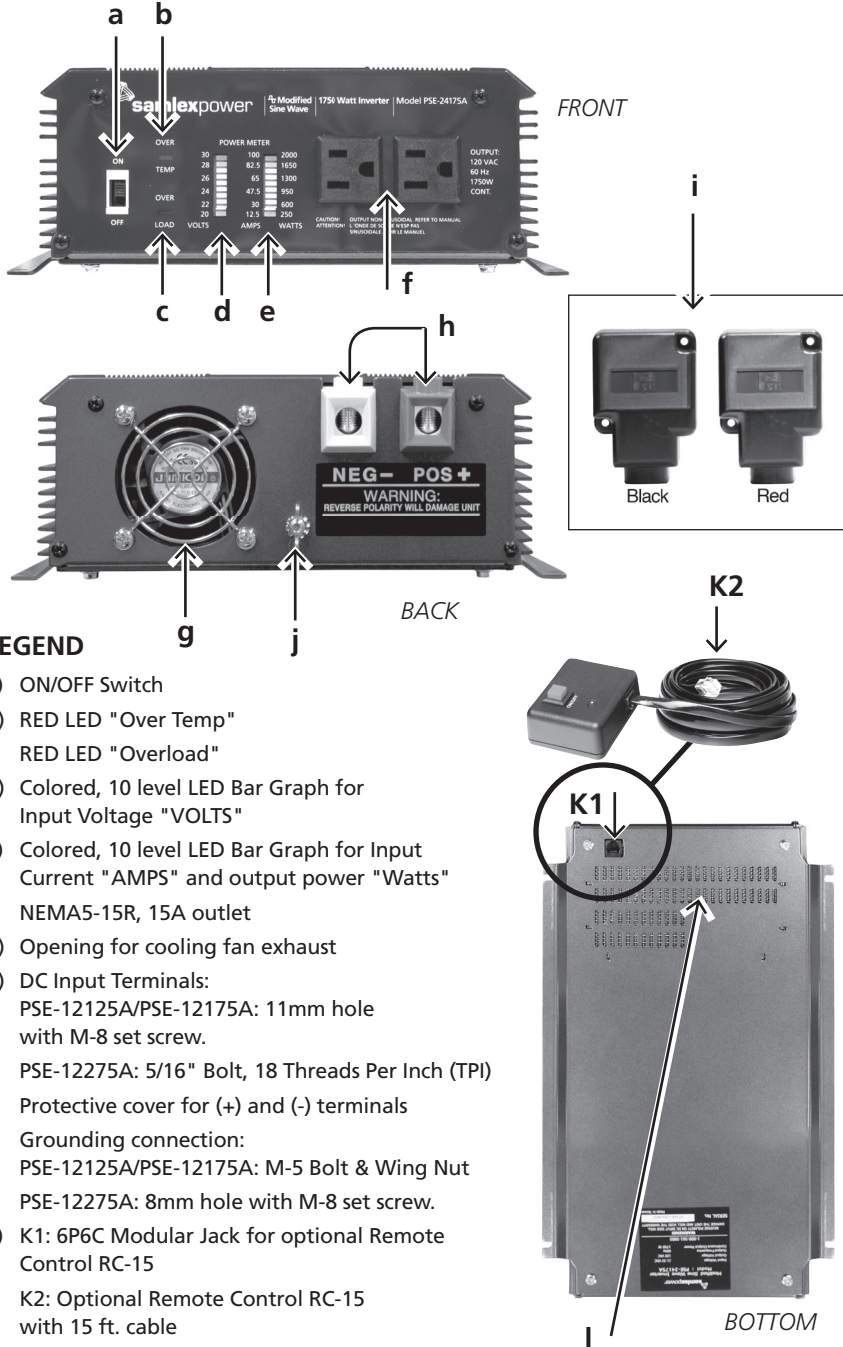

Fig 7.1. Layout: PSE-12125A, PSE-12175A





SECTION 7 | Layout, Controls & Indications

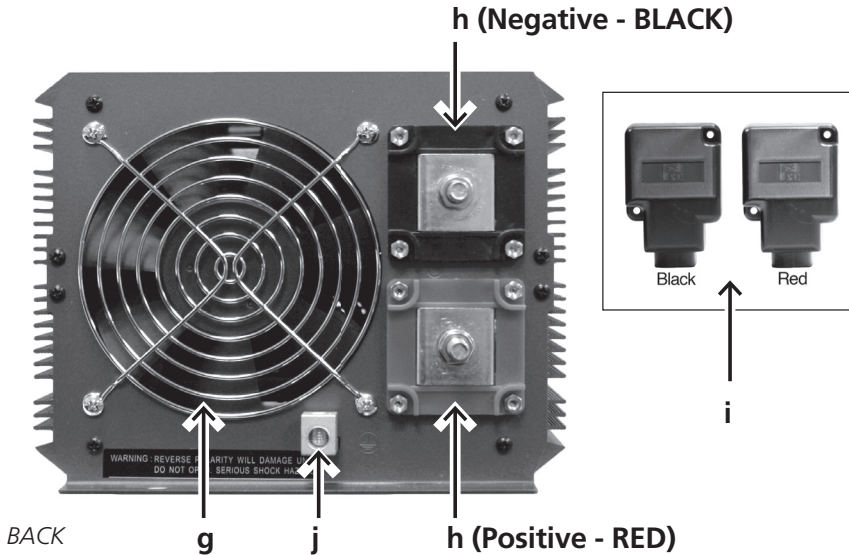
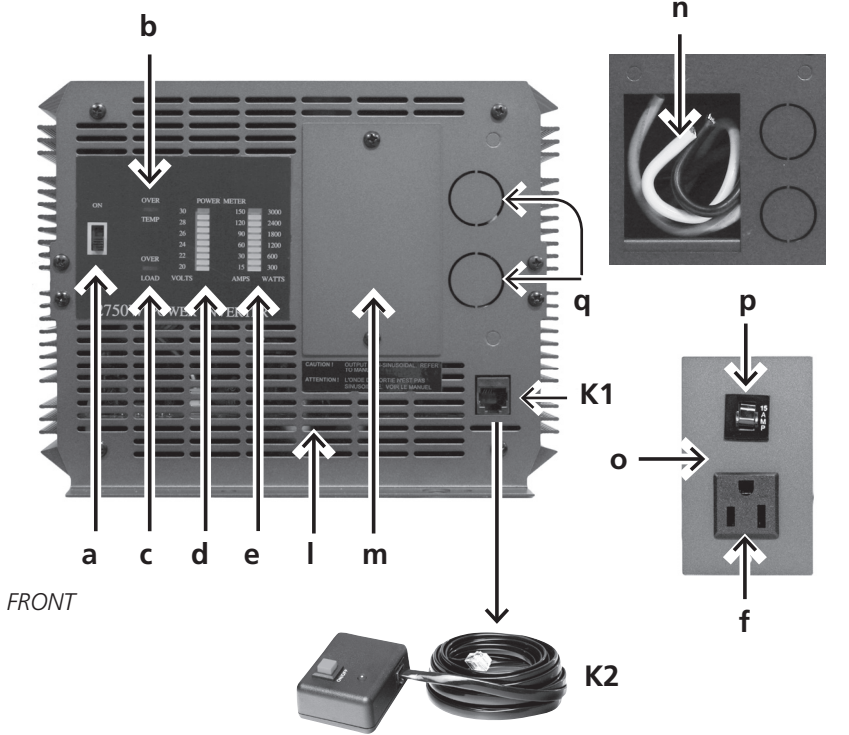

Fig. 7.2. Layout: PSE-12275A





SECTION 7 | Layout, Controls & Indications

LEGEND (Fig 7.2)

- a) ON/OFF Switch
- b) RED LED "Over Temp"
- c) RED LED "Overload"
- d) Colored LED, 10 level LED Bar Graph for Input Voltage "VOLTS"
- e) Coloured, 10 level LED Bar Graph for Input Current "AMPS"
- f) NEMA5-15R, 15A outlet
- g) Opening for cooling fan exhaust
- h) DC Input Terminals:
PSE-12125A/PSE-12175A: 11mm hole with M-8 set screw.
PSE-12275A: 5/16" Bolt, 18 Threads Per Inch (TPI)
- i) Protective cover for (+) and (-) terminals
- j) Grounding connection:
PSE-12125A/PSE-12175A: M-5 Bolt & Wing Nut
PSE-12275A: 8mm hole with M-8 set screw.
- k) K1: 6P6C Modular Jack for optional Remote Control RC-15
K2: Optional Remote Control RC-15 with 15 ft. cable
- l) Ventilation slots for air intake
- m) Cover plate for AC Output Pocket (PSE-12275A)
- n) AC output pocket behind Cover Plate (m). Inside the pocket, 3 AWG #10, 7" length each, Black, White and Green wires are provided for hardwiring of AC output (PSE-12275A)
- o) Separate plate with 1 x NEMA5-15R outlet (f) [PSE-12275A]
- p) 15A AC breaker
- q) Knock outs for AC output wiring: 22mm hold for 3/8" fitting for cable entry (PSE-12275A)



SECTION 8 | Principle of Operation

The inverter converts 24V (nominal) DC voltage of the battery to 120V, 60 Hz AC voltage.

The voltage conversion takes place in two stages. In the first stage, the 24V (nominal) DC voltage of the battery is converted to high voltage DC (155V to 170V) using high frequency switching and Pulse Width Modulation (PWM) technique. In the second stage, the high voltage DC is converted to 120V, 60 Hz. modified sine-wave AC.

Note: 120V is the RMS value of the AC voltage. The peak value of the AC voltage will be equal to the value of the above high voltage. See Fig. 8.1 below.

The output wave form of the inverter is a modified sine wave (see Fig. 8.1 given below). In a sine wave, the voltage rises and falls smoothly with a smoothly changing phase angle and also changes its polarity instantly when it crosses 0 Volts. In a modified sine wave, the voltage rises and falls abruptly, the phase angle also changes abruptly and it sits at 0 Volts for some time before changing its polarity.

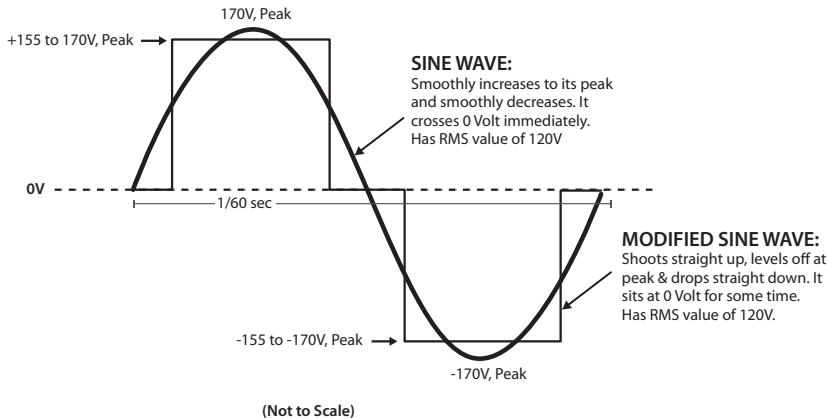

Fig. 8.1: Difference between Sine & Modified Sine Wave Forms.

MEASURING MODIFIED SINE-WAVE VOLTAGE WITH A VOLTMETER

The modified sine-wave AC produced by the inverter has an RMS (Root Mean Square) value of 120V. A general purpose AC voltmeter is designed to accurately measure the RMS value of a normal sine-wave and not a modified sine-wave. If this voltmeter is used to read the AC voltage of a modified sine-wave, it will indicate a lower value (96V to 104V). For accurately measuring the voltage of a modified sine wave, use a voltmeter which is designed to measure "True RMS values" like Fluke 87, Fluke 8060A, etc.





SECTION 8 | Principal of Operation

DEVICES THAT MAY NOT OPERATE ON MODIFIED SINE WAVE

The output wave form of these inverters is a modified sine wave (see Fig. 8.1, page 30). In a sine wave, the voltage rises and falls smoothly with a smoothly changing phase angle and also changes its polarity instantly when it crosses 0 Volts. In a modified sine wave, the voltage rises and falls abruptly, the phase angle also changes abruptly and it sits at 0 Volts for some time before changing its polarity. Thus, any device that uses a control circuitry that senses the phase (for voltage / speed control) or instantaneous zero voltage crossing (for timing control) does not work properly.

Also, as the modified sine wave is a form of square wave, it is comprised of multiple sine waves of odd harmonics (multiples) of the fundamental frequency of the modified sine wave. For example, a 60Hz modified sine wave will consist of sine waves with odd harmonic frequencies of 3rd (180Hz), 5th (300Hz), 7th (420Hz) and so on. The high frequency harmonic content produces enhanced radio interference, higher heating effect in motors / microwaves and produces overloading due to lowering of the impedance of low frequency filter capacitors / Power Factor improvement capacitors.

NOTE: Electric motors and microwaves will run Hotter when operated with modified sine wave. Please ensure proper ventilation for adequate cooling.

Some examples of devices that may not work properly with modified sine wave and may also get damaged are given below:

- The built-in clocks in devices such as clock radios, alarm clocks, coffeemakers, bread-makers, VCR, microwave ovens etc may not keep time correctly.
- Output voltage control devices like dimmers, ceiling fan / motor speed control may not work properly (dimming / speed control may not function).
- Transformer-less capacitive input powered devices like (i) Razors, flashlights, night-lights, smoke detectors etc (ii) Re-chargers for battery packs used in hand power tools. These may get damaged. Please check with the manufacturer of these types of devices for suitability.
- Devices that use radio frequency signals carried by the AC distribution wiring.
- Oil burner primary controls / some new furnaces with microprocessor controls
- High intensity discharge (HID) lamps like Metal Halide lamps. These may get damaged. Please check with the manufacturer of these types of devices for suitability.
- Some fluorescent lamps that have Power Factor correction capacitors. The inverter may shut down indicating overload.
- Sewing machines with speed / microprocessor control.



SECTION 9 | Installation

The success of a DC to AC power inverter installation depends mainly on the methods and materials used for installation. Please read and comply with instructions given below.

GENERAL

Installation and Wiring Compliance

- Installation and wiring must comply with the local and the national electrical codes and must be done by a certified electrician.
- In building / residential applications, electrical codes do not allow permanent connection of AC distribution wiring to the inverter's AC output receptacles. The receptacles are intended for temporary (as needed) connection of cord connected loads only. (Model PSE-12275A has a provision for hard wiring to an electrical breaker panel / load center. Read details under "AC Power Distribution and Grounding" on page 10.
- The inverter does not have integral over current protection for the AC output side (Except in the case of model PSE-12275A where a 15A breaker is provided if part of AC output power is to be fed directly from the front panel of the unit through the NEMA 5-15R receptacle). Protection should be provided by the installer.
NOTE: AC power drawn from the NEMA5-15 outlet should be limited to 1500W only. For extracting the full 2750W, hardwiring connection should be used.
- Over current protection of the cables from the battery to the inverter has to be provided by the installer.
- The DC input Positive and Negative terminals are isolated from the chassis. Similarly, the Neutral pole of the AC receptacles / the Neutral wire is not bonded to the chassis. System grounding to suit the national / local electrical codes is to be undertaken by the installer. Read details under "AC Power Distribution and Grounding" on page 10.

Preventing Electrical Shock

Always connect the grounding connection on the inverter to the appropriate grounding system. Read details under "AC Power Distribution and Grounding" on page 10.

Installation Environment

- The inverter should be installed indoor only in a well ventilated, cool, dry environment.
- Do not expose to moisture, rain, snow or liquids of any type.
- To reduce the risk of overheating and fire, do not obstruct the intake and discharge openings of the cooling fan.
- To ensure proper ventilation, do not install in a low clearance compartment.
- Working with the inverter may produce arcs or sparks. Thus, the inverter should not be used in areas where there are inflammable materials or gases requiring ignition protected equipment. These areas may include spaces containing gasoline powered machinery, fuel tanks, battery compartments.





SECTION 9 | Installation

Mounting Position of the Inverter

The inverter may be mounted horizontally on the top of a horizontal surface or under a horizontal surface. The inverter may be mounted on a vertical surface only horizontally (the fan axis should always be horizontal i.e. the fan should not be pointing up or down).

Cooling by Forced Air Fan Ventilation

The inverters produce heat when operating. The amount of heat produced is proportional to the amount of power supplied by the inverter. DC fans are used to provide forced air cooling of these inverters. The fans are thermostatically controlled and will be switched ON only if the temperature of certain Hot spot inside the inverter rises above a certain temperature. At lower loads and / or at lower ambient temperatures, the fan may not switch ON at all. This is normal. The units are protected against over-temperature due to failure of the fan / inadequate heat transfer. The AC output will be shut-down if the Hot spot inside the inverter reaches a certain higher temperature. The unit will automatically reset once it cools down.

Precautions when Working with Batteries.

- Batteries contain very corrosive diluted Sulphuric Acid as electrolyte. Precautions should be taken to prevent contact with skin, eyes or clothing.
- Batteries generate Hydrogen and Oxygen during charging resulting in evolution of explosive gas mixture. Care should be taken to ventilate the battery area and follow the battery manufacturer's recommendations.
- Never smoke or allow a spark or flame near the batteries.
- Use caution to reduce the risk of dropping a metal tool on the battery. It could spark or short circuit the battery or other electrical parts and could cause an explosion.
- Remove metal items like rings, bracelets and watches when working with batteries. The batteries can produce a short circuit current high enough to weld a ring or the like to metal and thus cause a severe burn.
- If you need to remove a battery, always remove the ground terminal from the battery first. Make sure that all the accessories are OFF so that you do not cause a spark.

DC SIDE CONNECTIONS

The DC input power to the inverter is derived from deep cycle batteries of the required capacity. Read under "Section 6" on page 15 for details on sizing and charging of batteries.

Preventing Input Over Voltage

It is to be ensured that the input voltage of the inverter does not exceed 16.5 VDC to prevent permanent damage to the inverter. Please observe the following precautions:

- Ensure that the maximum charging voltage of the battery charger / alternator / solar charge controller is below 16.5 VDC.



SECTION 9 | Installation

- Do not use unregulated solar panels to charge a battery. Under cold ambient temperatures, the output of the solar panel may exceed 16.5 VDC. Always use a charge controller between the solar panel and the battery.
- Do not connect to a battery system with a voltage higher than 12 VDC nominal.

Preventing Reverse Polarity on the Input Side

When making battery connection on the input side, make sure that the polarity of battery connection is correct (connect the Positive of the battery to the Positive terminal of the inverter and the Negative of the battery to the Negative terminal of the inverter). If the input is connected in reverse polarity, fuse(s) on the DC input side will blow and may also cause permanent damage to the inverter.

Connection from the Batteries to the DC Input Side of the Inverter – Cable and Fuse Sizes

The flow of electric current in a conductor is opposed by the resistance of the conductor. The resistance of the conductor is directly proportional to the length of the conductor and inversely proportional to its cross-section (thickness). The resistance in the conductor produces undesirable effects of voltage drop and heating. Thus, thicker and shorter conductors are desirable. The size (thickness / cross-section) of the conductors is designated by AWG (American Wire Gauge) or in mm².

The DC input circuit is required to handle very large DC currents and hence, the size of the cables and connectors should be selected to ensure minimum voltage drop between the battery and the inverter. Thinner cables and loose connections will result in poor inverter performance and will produce abnormal heating leading to risk of insulation melt down and fire.

Use oil resistant, multi-stranded copper wire cables rated at 105°C / 194°F minimum. Do not use aluminium cable as it has higher resistance per unit length. Cables can be bought at a marine / welding supply store.

The cables from the battery to the inverter should be protected by a suitable, very fast acting DC fuse. Use a DC fuse of the appropriate capacity in line with the Positive cable. The fuse should be within 18" from the battery. Class-T or Marine Rated Battery Fuse (MRBF) are recommended.

The following size of cables and fuses are recommended. The distance shown is the distance between the battery and the inverter. The recommended size of the cables will limit the voltage drop up to 3% (The length of the cable for calculating the voltage drop has been taken as 2 times the distance between the inverter and the battery because voltage drop occurs due to the resistance of the Positive and Negative cables.





SECTION 9 | Installation

Model	Distance up to 10 ft.	Ampere rating of fuse	Samlex Inverter Installation Kit
PSE-12125A	#2 AWG	175A to 200A	DC-2000-KIT
PSE-12175A	#2/0 AWG	280A to 300A	DC-2500-KIT
PSE-12275A	#4/0 AWG	360A to 400A	DC-3500-KIT



CAUTION!

The input section of the inverter has large value capacitors connected across the input terminals. As soon as the DC input connection loop [Battery (+) → Fuse → Inverter (+) → Inverter (-) → Battery (-)] is completed, these capacitors will start charging and will momentarily draw very heavy current that will produce sparking on the last contact in the input loop even when the ON/OFF switch on the inverter is in the OFF position. Ensure that the fuse is inserted only after all the connections in the loop have been completed so that the sparking is limited to the fuse area.

Using Proper DC Cable Termination

The battery end and the inverter end of the cables should have proper terminals that will ensure a firm and tight connection.

DC Input Terminals on PSE-12125A and PSE-12175A

The DC input terminals on PSE-12125A and PSE-12175A have a tubular hole with a set screw (h, Fig. 7.1). A suitable pin type of copper terminal should, therefore, be used on the cable end. (A pair of pin type terminals has been provided. Crimp these terminals on the inverter end of the cables) Do not insert the stranded bare end of the cable directly into the tubular hole as the set screw will not pinch all the strands and will thus make only a partial and loose contact. For thicker cables, a suitable adapter with pin type of termination should be used. There should be no stray wire strands protruding from the terminals as these may produce a short circuit due to the close vicinity of the Positive and Negative terminals.

DC Input Terminals on PSE-12275A

The DC input terminals on PSE-12275A have nut and bolt connections that will accept 3/8 inch ring terminal (h, Fig. 7.2). Use appropriate compression lugs or aluminium box lugs. There should be no stray wire strands protruding from the terminals as these may produce a short circuit due to the close vicinity of the plus and minus terminals After the DC input cables have been connected, cover the terminals with the plastic protective covers provided (i, Fig. 7.2).

Reducing RF Interference

To reduce the effect of radiated interference, twist the DC side cables. To further reduce RF interference, shield the cables with sheathing /copper foil / braiding.



SECTION 9 | Installation

Taping Battery Cables Together to Reduce Inductance.

Do not keep the battery cables far apart. In case it is not convenient to twist the cables, keep them taped together to reduce their inductance. Reduced inductance of the battery cables helps to reduce induced voltages. This reduces ripple in the battery cables and improves performance and efficiency.

AC SIDE CONNECTIONS

Preventing Paralleling of the AC Output

The AC output of the inverter cannot be synchronised with another AC source and hence, it is not suitable for paralleling. The AC output of the inverter should never be connected directly to an electrical breaker panel / load center which is also fed from utility power / generator. Such a connection may result in parallel operation of the different power sources and the AC power from the utility / generator will be fed back into the inverter which will instantly damage the output section of the inverter and may also pose a fire and safety hazard. If an electrical breaker panel / load center is fed from an inverter and this panel is also required to be powered from additional alternate AC sources, the AC power from all the AC sources like the utility / generator / inverter should first be fed to a manual selector switch and the output of the selector switch should be connected to the electrical breaker panel / load center. A suitable Automatic Transfer Switch may also be used, e.g. Samlex America Model STS-30.

To prevent possibility of paralleling and severe damage to the inverter, never use a simple jumper cable with a male plug on both ends to connect the AC output of the inverter to a handy wall receptacle in the home / RV.

Connecting to Multi-Wire Branch Circuits

Do not directly connect the Hot side of the 120 VAC of the inverter model to the two Hot legs of the 120 / 240 VAC electrical breaker panel / load centre where multi-wire (common Neutral) branch circuit wiring method is used for distribution of AC power. This may lead to overloading / overheating of the Neutral conductor and is a risk of fire.

A Split Phase Transformer (Isolated or Autotransformer) of suitable wattage rating (25% more than the wattage rating of the inverter) with primary of 120 VAC and secondary of 120 / 240 VAC (Two 120 VAC split phases 180 degrees apart) should be used. The Hot and Neutral of the 120 VAC output of the inverter should be fed to the primary of this transformer and the 2 Hot outputs (120 VAC split phases) and the Neutral from the secondary of this transformer should be connected to the electrical breaker panel / load centre.

AC Output Connections - PSE-12125A / PSE-12175A

These inverters use NEMA 5-15R receptacles (f, Fig. 7.1) for connecting the AC output to devices and appliances fitted with a NEMA 5-15P plug. In these NEMA 5-15 R receptacles, two rectangular slots are connected to the current-carrying conductors of the AC power source inside the inverter. The round slot is the "equipment grounding" connection and is internally connected to the metal chassis of the inverter.



SECTION 9 | Installation



CAUTION!

In these NEMA 5-15R receptacles, the current carrying conductor connected to the longer rectangular slot is isolated from the metal chassis of the inverter. Hence, when the metal chassis of the inverter is connected to the earth ground, the longer rectangular slot is not grounded to earth ground. The longer rectangular slot is, therefore, not a “Neutral”. Do not touch this slot as it will be at an elevated voltage with respect to the metal chassis / earth ground and may produce an electrical shock when touched.

AC Output Connections - PSE-12275A

The AC output connections (n, Fig. 7.2) have three insulated conductors – one BLACK and one WHITE for carrying current and one GREEN for “equipment grounding”. The GREEN color “equipment grounding” conductor is connected to the metal chassis of the inverter. These three conductors exit through a pocket in the front side of the inverter (n, Fig 7.2). These three conductors are used for hard-wiring the inverter to a breaker panel. Use the insulated wire nuts (Marette) / butt splices provided to splice the wires. For drawing the full 2750W power from the inverter, the output conductors should be hard wired to a suitable breaker panel.

A separate plate (p, Fig. 7.2) which has a NEMA 5-15R receptacle wired through a 15A breaker has also been provided. This plate with the receptacle and breaker fits in the pocket through which the output conductors exit the inverter (n, Fig. 7.2). The NEMA5-15R receptacle can be connected to the three output conductors if the AC power output is required to be drawn from the front panel of the inverter. Use the insulated wire nuts (Marette) / butt splices provided to splice the wires. **Please note that the NEMA 5-15R receptacle is wired through a 15A breaker and hence, the power delivered from this receptacle will be limited to 1500 watts only.**



CAUTION!

The White current carrying conductor is not bonded to the metal chassis of the inverter. Hence, when the metal chassis of the inverter is connected to the earth ground, this White/ current carrying conductor will not be grounded to earth ground. The white conductor is, therefore, not a “Neutral”. Do NOT touch this conductor as it will be at an elevated voltage with respect to the metal chassis / earth ground and may produce electrical shock.

Grounding of PSE-12125A / PSE-12175A to Earth or to Other Designated Ground

Please see details regarding grounding under “AC Power Distribution and Grounding” on page 10. For safety, the metal chassis of the inverter is required to be grounded to the earth ground or to the other designated ground (For example, in a mobile RV, the metal frame of the RV is normally designated as the Negative DC ground). An equipment grounding bolt with a wing nut (j, Fig. 7.1) has been provided for grounding the metal chassis of the inverter to the appropriate ground.



SECTION 9 | Installation

When using the inverter in a building, connect a #8 AWG insulated stranded copper wire from the above equipment grounding bolt to the earth ground connection (a connection that connects to the ground rod or to the water pipe or to another connection that is solidly bonded to the earth ground). The connections must be tight against bare metal. Use star washers to penetrate paint and corrosion.

When using the inverter in a mobile RV, connect a #8 AWG insulated stranded copper wire from the above equipment grounding bolt to the appropriate ground bus of the RV (usually the vehicle chassis or a dedicated DC ground bus). The connections must be tight against bare metal. Use star washers to penetrate paint and corrosion.

Grounding of PSE-12275A to Earth or to Other Designated Ground

Please see details regarding grounding under "AC Power Distribution and Grounding" on page 10. In case of hard wiring of the PSE-12275A to a building's service entrance / electrical breaker panel / load center, proper grounding and bonding have to be undertaken as per the applicable national / local electrical codes. In such cases, the electrical installation should be undertaken by a qualified electrician.

When the AC output is fed through NEMA5-15R outlet, connect #8 AWG insulated stranded copper wire from the equipment grounding bolt (j, Fig 7.2) to the earth ground connection (a connection that connects to the ground rod or to the water pipe or to another connection that is solidly bonded to the earth ground). The connections must be tight against bare metal. Use star washers to penetrate paint and corrosion.

When using these inverters in a mobile RV, connect a #8 AWG insulated stranded copper wire from the equipment grounding bolt (j, Fig 7.2) to the appropriate ground bus of the RV (usually the vehicle chassis or a dedicated DC ground bus). The connections must be tight against bare metal. Use star washers to penetrate paint and corrosion.





SECTION 10 | Operation

POWERING ON THE LOADS

After the inverter is switched ON, it takes a finite time for it to become ready to deliver full power. Hence, always switch on the load(s) after a few seconds of switching ON the inverter. Avoid switching ON the inverter with the load already switched ON. This may prematurely trigger the overload protection.

When a load is switched ON, it may require initial higher power surge to start. Hence, if multiple loads are being powered, they should be switched ON one by one so that the inverter is not overloaded by the higher starting surge if all the loads are switched ON at once.

SWITCHING THE INVERTER ON/OFF

Before switching ON the inverter, check that all the AC loads have been switched OFF.

The ON/OFF switch (a, Fig. 7.1 or 7.2) on the front panel of the inverter is used to switch ON and switch OFF the AC power output of the inverter. This switch operates a low power control circuitry which in turn controls all the high power circuitry.



CAUTION!

Please note that this switch is not switching the high power battery input circuit. Parts of the DC side circuit will still be alive even when the switch is in the OFF position. Hence, disconnect the DC and AC sides before working on any circuits connected to the inverter.

When the inverter is switched ON, the colored, 10 level LED Bar Graph for DC input voltage (d, Fig. 7.1 or 7.2) will be lighted and the voltage at the input terminals will be indicated. It should read between 12 to 13 volts if the batteries are fully charged.

Switch ON the AC load(s). The colored, 10 level LED Bar Graph for DC input current / output power (e, Fig. 7.1 or 7.2) will show the current drawn by the inverter from the batteries and the corresponding AC output power in Watts. The value of the current drawn will be proportional to the AC power drawn by the load. The voltage shown will decrease slightly and this decrease will be proportional to the power drawn by the load

DC INPUT VOLTAGE DISPLAY

The colored, 10 level LED Bar Graph (d, Fig. 7.1 or 7.2) indicates the voltage at the DC input terminals of the inverter. The voltage at the DC input terminals will always be less than the voltage at the battery terminals due to drop in voltage in the battery side cables and connectors. When there is no load connected to the inverter, the DC input voltage at the inverter terminals will be almost same as the voltage at the battery terminals. If the batteries are fully charged, the voltage display should read between 12 to 13 Volts. As the AC power delivered by the inverter increases, the value of the DC input



SECTION 10 | Operation

current will increase. At the same time, the value of voltage at the DC input terminals will decrease due to internal voltage drop in the battery and also due to external voltage drop in the DC input cables.

Indications for Normal Operation

When the inverter is operating normally and supplying AC load(s), only the voltage and current/power LED Bar Graphs will be ON. In case of abnormal operation, other displays and alarms will be activated. Please see under "Protections Against Abnormal Conditions" on page 41.

Switching ON/OFF Using the Optional ON/OFF Remote Control

An optional wired Remote Control, Model No. RC-15 (K2, Fig. 7.1 or 7.2), is available to enable switching ON and OFF from a distance of 15 ft. The Remote ON/OFF Control comes with 15 ft. of cable. One end of the Remote Control is plugged into the 6P6C modular jack (K1, Fig. 7.1 or 7.2) provided on the inverter. To use the Remote Control, the inverter is first required to be switched ON from the ON/OFF switch on the front panel. Now, the inverter can be toggled between ON/OFF conditions by pressing the ON/OFF Push Button on the Remote Control. The LED on the Remote Control will light when the inverter is in the ON condition.

No Load Current Draw (Idle Current)

When the ON/OFF switch on the inverter or on the optional Remote Control RC-15 is turned ON, all the circuitry inside the inverter becomes alive and the AC output is made available. In this condition, even when no load is being supplied (or, if a load is connected but has been switched OFF), the inverter draws a small amount of current from the batteries to keep the circuitry alive and ready to deliver the required power on demand. This is called the "Idle Current" or the "No Load Current" draw. Hence, when the load is not required to be operated, turn OFF the ON/OFF switch on the inverter to prevent unnecessary current drain from the battery. When the inverter is switched OFF while using the optional Remote Control RC-15, the current drawn from the battery will be < 5mA.

SECTION 11 | Protections Against Abnormal Conditions

Low DC Input Voltage Warning Alarm: The voltage at the DC input terminals will be lower than the voltage at the battery terminals due to internal voltage drop in the battery and the voltage drop in the battery cables and connectors. The drop in the voltage at the DC input terminals of the inverter could be due to lower battery voltage, or high internal resistance of the battery due to sulfation, or due to abnormally high drop in the cables if the cables are not thick enough (Please read under "Connection from Batteries to DC Input Side of the Inverter Cable and Fuse Sizes" on page 34) If the voltage at the DC input terminals falls below 10.5V, a buzzer alarm will be sounded. The AC output





SECTION 11 | Protections Against Abnormal Conditions

voltage will continue to be available. This warning alarm indicates that the battery is running low and that the inverter will be shut down after sometime if the voltage at the inverter terminals further drops to 10V. The alarm will reset automatically when voltage rises above 10.5V.

Shut-Down Due to Low DC Input Voltage: If the inverter continues to power the load after the low DC input voltage buzzer alarm is sounded, it will shut down completely when the DC input voltage further drops below 10V. There will be no AC output voltage and the alarm will continue to sound. The unit will be reset automatically when the input voltage rises to 11.3V.

Shut-down Due to High DC Input Voltage: If the voltage at the DC input terminals exceeds 16.5V, the inverter will be shut down completely. The unit will reset automatically when input voltage drops below 16.5V.

Shut-down Due to Reversal of Polarity at the DC Input Terminals: The Positive of the battery should be connected to the Positive DC input terminal of the inverter and the Negative of the battery should be connected to the Negative DC input terminal of the inverter. A reversal of polarity (the Positive of the battery wrongly connected to the Negative DC input terminal of the inverter and the Negative of the battery wrongly connected to the Positive DC input terminal of the inverter) will blow the external DC side fuse and the DC input fuses inside the inverter. If the DC side fuses are blown, the inverter will be dead. There will be no indication of any voltage on the colored LED Bar Graph voltage indicator and also, there will be no AC output. The fuses should be replaced with the correct size of fuses shown under specifications. If the unit does not work after replacing the external and internal fuses, it has been permanently damaged. Please call Technical Support for assistance.

Shut-down Due to Over-temperature: In case of failure of the cooling fan or in the case of inadequate heat removal due to higher ambient temperatures / insufficient air exchange, the temperature inside the unit will increase. The temperature of a critical hot spot inside the inverter is monitored and at a particular upper limit, the AC output of the inverter is shut down temporarily. The RED Over Temp LED (b, Fig. 7.1 or 7.2) is lighted and a buzzer is sounded. The unit will automatically reset after the unit has cooled down.

Shut Down Due to Overload or Short Circuit on AC Output Side: Shut down will be activated under the following conditions:

- Continuous overload higher than the rated Maximum Continuous Active Power Output Rating
- Short time overload higher than the Surge Output Power Rating
- Short circuit

When this protection is activated, the AC output voltage will be shutdown and the Red Overload LED (c, Fig 7.1 or 7.2) will be lighted. **The unit will remain latched in shut down condition till it is reset manually.** Before resetting, remove the possible cause of overload or short circuit. To reset, switch OFF the unit with the help of the ON /OFF





SECTION 11 | Protections Against Abnormal Conditions

Switch (a, Fig 7.1 or 7.2), wait for 3 minutes and switch ON again.

NOTE: If the unit goes into overload once again, remove all the loads, reset as above and switch ON. If it goes into overload condition again without any load, it is defective. Please call Technical Support.

SECTION 12 | Troubleshooting Guide

SYMPTOM

On switching ON, the input voltage LED Bar Graph (d, Fig. 7.1 or 7.2) does not light. There is no AC voltage.

POSSIBLE CAUSE #1

There is no voltage at the DC input terminals

Remedy:

1. Check the continuity of the battery input circuit.
2. Check that the external battery fuse is intact. Replace if blown
3. Check that all connections in the battery input circuit are tight

POSSIBLE CAUSE #2

Input voltage of > 10.5V is available at the DC input terminals

Polarity of the DC input voltage has been reversed that has blown the internal DC side fuses.

Remedy:

Correct the polarity of the input connections and replace the internal fuses (**Note:** Reverse polarity may cause permanent damage). If the unit does not work after replacing the fuses, the unit has been permanently damaged. Call Technical Support.

SYMPTOM

AC output output voltage reads low (96 to 104 VAC) when measured with an ordinary voltmeter.

POSSIBLE CAUSE

The voltmeter being used is not designed to read the true RMS value of modified sine waveform.

Remedy:

Use true RMS reading voltmeter like Fluke 87.





SECTION 12 | Troubleshooting Guide

SYMPTOM

Low AC output voltage and the input current LED Bar Graph (d, Fig. 7.1 or 7.2) shows very high current (No buzzer alarm).

POSSIBLE CAUSE

Low voltage at the DC input terminals and the load is close to the maximum allowable power.

Remedy:

1. Check that the battery is fully charged. Recharge, if low.
2. Check that the battery cables are thick enough to carry the required current over the required length. Use thicker cables, if required.
3. Tighten connections of the battery input circuit.
4. Reduce the load.

SYMPTOM

Buzzer alarm is sounded when load is switched ON. DC input voltage LED Bar Graph (d, Fig. 7.1 or 7.2) reads between 10 and 10.5V. AC output voltage is available.

POSSIBLE CAUSE

Low input voltage at the inverter terminals and the load is close to the maximum allowable power.

Remedy:

1. Check that the battery is fully charged. Recharge, if low.
2. Check that the battery cables are thick enough to carry the required current over the required length. Use thicker cables, if required.
3. Tighten connections of the battery input circuit.

SYMPTOM

Buzzer alarm is sounded when load is switched ON. DC input voltage LED Bar Graph (d, Fig. 7.1 or 7.2) reads below 10V. There is no AC output.

POSSIBLE CAUSE

Shut-down due to low input DC voltage (Less than 10V). **Note:** The unit will re-set automatically when the input voltage rises to 11.3V.

Remedy:

1. Check that the battery is fully charged. Recharge, if low.
2. Check that the battery cables are thick enough to carry the required current over the required length. Use thicker cables, if required.
3. Tighten connections of the battery input circuit.



SECTION 12 | Troubleshooting Guide

SYMPTOM

There is no AC output. The voltage LED Bar Graph (d, Fig. 7.1 or 7.2) shows DC input voltage reading of 15V (full Bar Graph is lighted up to the top RED LED).

POSSIBLE CAUSE

Shut-down due to high input DC voltage (>16.5V). The unit will re-set automatically when the voltage drops below 16.5V.

Remedy:

1. Check that the voltage at the DC input terminals is less than 16.5V.
2. Ensure that the maximum charging voltage of the battery charger / alternator / solar charge controller is below 16.5V.
3. Ensure that an un-regulated solar panel is not used to charge a battery. Under cold ambient temperatures, the output of the solar panel may exceed 16.5V. Ensure that a charge controller is used between the solar panel and the battery.

SYMPTOM

The AC output drops momentarily and rises to normal automatically. Red Overload LED (c, Fig. 7.1 or 7.2) is not lighted (might happen during starting of certain loads).

POSSIBLE CAUSE

Temporary drop-in AC output voltage due to surge power overload within the Surge Power Rating of the inverter.

SYMPTOM

The AC output shuts down completely. The Red Overload LED (c, Fig. 7.1 or 7.2) is lighted.

POSSIBLE CAUSE

Permanent shut-down of the AC output due to continuous overload beyond the continuous / surge power rating of the inverter. **Note:** The unit will be latched in this shut-down condition. To reset, switch the power ON /OFF switch to OFF and then ON again. Before switching ON again, remove the cause of the shut-down.

Remedy:

1. Reduce the load.
2. The load is not suitable as it requires higher power to operate. Use an inverter with higher power rating.
3. If the unit goes into permanent overload again after resetting and removing the load completely, the unit has become defective. Call Technical support.





SECTION 12 | Troubleshooting Guide

SYMPTOM

Buzzer alarm is sounded. Red Over Temp LED is ON (b, Fig. 7.1 or 7.2).
There is no AC output.

POSSIBLE CAUSE

Shut-down due to over temperature because of fan failure or inadequate cooling as a result of high ambient temperature or insufficient air exchange.

Remedy:

1. Check that the fan is working. If not, the fan / fan control circuit may be defective. Call Technical Support.
2. If the fan is working, check that the ventilation slots on the suction side (l, Fig. 7.1 or 7.2) and the openings on the discharge side of the fan (g, Fig. 7.1 or 7.2) are not obstructed.
3. If the fan is working and the openings are not obstructed, check that enough cool replacement air is available. Also check that the ambient air temperature is less than 40°C / 104°F.
4. Reduce the load to reduce the heating effect.
5. After the cause of over heating is removed and the unit cools down, it will reset automatically.





SECTION 13 | Specifications

PARAMETER	PSE-12125A	PSE-12175A	PSE-12275A
OUTPUT			
OUTPUT VOLTAGE	120VAC +5% / - 10%		
OUTPUT FREQUENCY	60Hz ± 5%	60Hz ± 5%	60Hz ± 5%
OUTPUT VOLTAGE WAVEFORM	Modified Sine Wave		
MAXIMUM CONTINUOUS ACTIVE POWER OUTPUT (POWER FACTOR = 1)	1250 W*	1750W*	2750W*
MAXIMUM ACTIVE SURGE POWER OUTPUT (< 2 SEC, POWER FACTOR =1)	2500W*	3500W*	4500W*
PEAK EFFICIENCY	85% to 90%	85% to 90%	85% to 90%
INPUT			
DC INPUT VOLTAGE	12V Battery System (> 10.5VDC to < 16.5VDC)		
MAXIMUM DC INPUT CURRENT	< 175A	< 280A	< 360A
NO LOAD CURRENT DRAW	320mA	370mA	600mA
MONITORING AND INDICATIONS			
DC INPUT VOLTAGE, VOLTS	Colored, 10 Level LED Bar Graph		
DC INPUT CURRENT, AMPS AND ASSOCIATED OUTPUT POWER, WATTS	Colored, 10 Level LED Bar Graph		
OVER TEMPERATURE	Red LED + Buzzer Alarm		
OVERLOAD	Red LED	Red LED	Red LED
LOW DC INPUT VOLTAGE	Buzzer Alarm	Buzzer Alarm	Buzzer Alarm
PROTECTIONS			
COOLING	Temperature Controlled Fan		
OVER LOAD / SHORT CIRCUIT	<ul style="list-style-type: none"> • Shutdown if output power > Continuous / Surge Ratings • Manual Reset: Switch OFF, wait for 3 min and Switch ON 		
OVER TEMPERATURE	<ul style="list-style-type: none"> • Shut Down when temperature of internal hot spot > threshold • Automatic reset when unit cools down 		
HIGH DC INPUT VOLTAGE	<ul style="list-style-type: none"> • Shut down when DC Input Voltage >16.5VDC • Auto reset when voltage drops below 16.5VDC 		
LOW DC INPUT VOLTAGE	<ul style="list-style-type: none"> • Shut down when DC Input Voltage < 10VDC • Auto reset when voltage rises to > 11.3VDC 		
LOW DC INPUT VOLTAGE ALARM	<ul style="list-style-type: none"> • Buzzer alarm when DC Input Voltage < 10.5VDC • Auto reset when voltage rises > 10.5VDC 		





SECTION 13 | Specifications

PARAMETER	PSE-12125A	PSE-12175A	PSE-12275A
INTERNAL DC SIDE FUSES	Automotive Type ATC, 32V		
	175A (35A x 5 pcs.)	280A (35A x 8 pcs.)	360A (30A x 12 pcs.)
INPUT AND OUTPUT CONNECTIONS			
DC INPUT CONNECTIONS	Terminal with 11 mm diameter tubular hole and M8 set screw		5/16" bolt and nut, 18 TPI
AC OUTPUT CONNECTIONS	2 x NEMA5-15R Outlets		<ul style="list-style-type: none"> • 3 x AWG #10 wires in covered pocket for hard wiring to panel • 2 Knock Outs (Hole diameter 22 mm / 0.87") for 3/8" fitting for cable entry
			Plate with NEMA5-15R outlet and 15A Breaker for front panel outlet
REMOTE CONTROL CONNECTION	6P6C Modular Jack		
REMOTE CONTROL (OPTIONAL)	Wired Remote Control with 15 ft cable – Model RC-15		
ENVIRONMENTAL CONDITIONS			
OPERATING TEMPERATURE	0°C to 40°C / 32°F to 104°F		
STORAGE TEMPERATURE	-10°C to 65°C / 14°F to 149°F		
HUMIDITY	85% RH, Non Condensing		
GENERAL			
DIMENSIONS (W X D X H), MM	240 x 335 x 85	240 x 455 x 85	205 x 495 x 160
DIMENSIONS (W X D X H), INCHES	9.45 x 13.19 x 3.35	9.45 x 17.91 x 3.35	8.07 x 19.49 x 6.30
WEIGHT, KG.	3.08	4.26	7.35
WEIGHT, LBS.	6.8	9.4	16.2
NOTES:			
1) * This is the Active Power output for resistive type of load with Power Factor = 1. For reactive loads, the rating will be reduced by the Power Factor of particular type of load (0.8 to 0.6)			
2) Specifications are subject to change without notice.			



SECTION 14 | Warranty

2 YEAR LIMITED WARRANTY

PSE-12125A, PSE-12175A, PSE-12275A manufactured by Samlex America, Inc. (the “Warrantor”) is warranted to be free from defects in workmanship and materials under normal use and service. The warranty period is 2 years for the United States and Canada, and is in effect from the date of purchase by the user (the “Purchaser”).

Warranty outside of the United States and Canada is limited to 6 months. For a warranty claim, the Purchaser should contact the place of purchase to obtain a Return Authorization Number.

The defective part or unit should be returned at the Purchaser’s expense to the authorized location. A written statement describing the nature of the defect, the date of purchase, the place of purchase, and the Purchaser’s name, address and telephone number should also be included.

If upon the Warrantor’s examination, the defect proves to be the result of defective material or workmanship, the equipment will be repaired or replaced at the Warrantor’s option without charge, and returned to the Purchaser at the Warrantor’s expense. (Contiguous US and Canada only)

No refund of the purchase price will be granted to the Purchaser, unless the Warrantor is unable to remedy the defect after having a reasonable number of opportunities to do so. Warranty service shall be performed only by the Warrantor. Any attempt to remedy the defect by anyone other than the Warrantor shall render this warranty void. There shall be no warranty for defects or damages caused by faulty installation or hook-up, abuse or misuse of the equipment including exposure to excessive heat, salt or fresh water spray, or water immersion.

No other express warranty is hereby given and there are no warranties which extend beyond those described herein. This warranty is expressly in lieu of any other expressed or implied warranties, including any implied warranty of merchantability, fitness for the ordinary purposes for which such goods are used, or fitness for a particular purpose, or any other obligations on the part of the Warrantor or its employees and representatives.

There shall be no responsibility or liability whatsoever on the part of the Warrantor or its employees and representatives for injury to any persons, or damage to person or persons, or damage to property, or loss of income or profit, or any other consequential or resulting damage which may be claimed to have been incurred through the use or sale of the equipment, including any possible failure of malfunction of the equipment, or part thereof. The Warrantor assumes no liability for incidental or consequential damages of any kind.

Samlex America Inc. (the “Warrantor”)
www.samlexamerica.com





Contact Information

Toll Free Numbers

Ph: 800 561 5885

Fax: 888 814 5210

Local Numbers

Ph: 604 525 3836

Fax: 604 525 5221

Website

www.samlexamerica.com

USA Shipping Warehouse

Kent WA

Canadian Shipping Warehouse

Delta BC

Email purchase orders to

orders@samlexamerica.com



samlexamerica®

