

2 YEAR LIMITED WARRANTY

The CFB1-200 and CFB2-400 fuse blocks manufactured by Samlex America Inc. (the "Warrantor") are warranted to be free from defects in workmanship and materials under normal use and service. The warranty period is 2 years for the United States and Canada, and is in effect from the date of purchase by the user (the "Purchaser").

Warranty outside of the United States and Canada is limited to 6 months. For a warranty claim, the Purchaser should contact the place of purchase to obtain a Return Authorization Number.

The defective part or unit should be returned at the Purchaser's expense to the authorized location. A written statement describing the nature of the defect, the date of purchase, the place of purchase, and the Purchaser's name, address and telephone number should also be included.

If upon the Warrantor's examination, the defect proves to be the result of defective material or workmanship, the equipment will be repaired or replaced at the Warrantor's option without charge, and returned to the Purchaser at the Warrantor's expense. (Contiguous US and Canada only)

No refund of the purchase price will be granted to the Purchaser, unless the Warrantor is unable to remedy the defect after having a reasonable number of opportunities to do so. Warranty service shall be performed only by the Warrantor. Any attempt to remedy the defect by anyone other than the Warrantor shall render this warranty void. There shall be no warranty for defects or damages caused by faulty installation or hook-up, abuse or misuse of the equipment including exposure to excessive heat, salt or fresh water spray, or water immersion.

No other express warranty is hereby given and there are no warranties which extend beyond those described herein. This warranty is expressly in lieu of any other expressed or implied warranties, including any implied warranty of merchantability, fitness for the ordinary purposes for which such goods are used, or fitness for a particular purpose, or any other obligations on the part of the Warrantor or its employees and representatives.

There shall be no responsibility or liability whatsoever on the part of the Warrantor or its employees and representatives for injury to any persons, or damage to person or persons, or damage to property, or loss of income or profit, or any other consequential or resulting damage which may be claimed to have been incurred through the use or sale of the equipment, including any possible failure of malfunction of the equipment, or part thereof. The Warrantor assumes no liability for incidental or consequential damages of any kind.

Samlex America Inc. (the "Warrantor")
www.samlexamerica.com



103 - 4268 Lozells Ave.
 Burnaby, BC
 Canada V5A 0C6

T: 604 525 3836
 F: 604 525 5221
 TF: 1 800 561 5885

samlex@samlexsolar.com
www.samlexsolar.com

11013-CFB1-CFB2-1021
 MAN-10006



Class T Fuse Blocks

CFB1-200
 200 Amp

CFB2-400
 400 Amp

Owner's Manual

Please read this manual before installing your fuse block

INTRODUCTION

The CFB1-200 and the CFB2-400 are fuse blocks with a 200A and 400A Class T fuse. The assembly is designed for surface mounting and incorporates a screw down terminal for cable termination.

These fuse blocks should be installed as close to the battery on the positive side (in a positive system) to limit injury and damage caused by a short circuit of the positive side of the battery.

CONSTRUCTION

The Class T Fuse Block (Fig. 1) contains the following components:

- Fuse Holder: A fiberglass insulated base with a removable polycarbonate cover
- Class T Type Fuse: 200A or 400A Fuse (JLLN or equivalent); 20 k Interrupting Capacity (DC)
 - CFB1-200 comes with a 200A Fuse.
 - CFB2-400 comes with a 400A Fuse.
- A CFB1 will not support a 400A Fuse and the CFB2 will not support a 200A Fuse



Fig. 1.CFB1 and CFB2 Class "T" Fuse Assembly

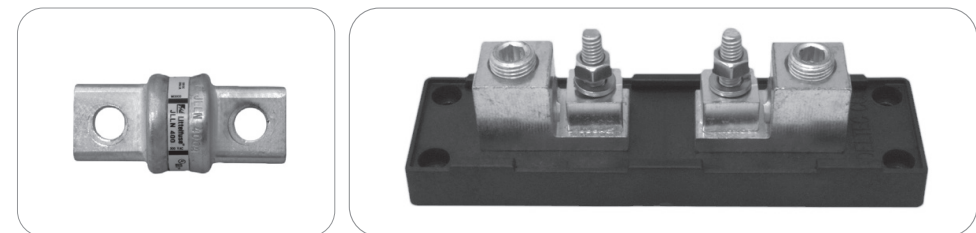

Fig 2 Class "T" Fuse and Fuse Block

INSTALLATION

Selecting a Location: The fuse assembly should be installed as close to the positive terminal of the battery as possible. Less than 6 to 8 inches is recommended to allow for adequate protection as well as space for cable and terminations. Any short circuit that occurs between the fuse and the battery remains unprotected by the fuse.

Maximum Cable Size: The diameter of the hole in the screw down terminal for the cable entry is 0.6" and is large enough for an AWG #4/0 stranded cable.

- 1) Cut the Positive cable based on the desired location of the Class "T" Fuse Block using wire cutters.
- 2) Strip 1.05" of the insulation at the cut ends using a stripper. Ensure that the innermost layer of the tape separator is completely removed. See Fig. 3.
- 3) «Insert the bare ends of the cable into the hole for the cable entry and tighten the screw down terminals firmly. Attach the clear polycarbonate snap on cover. See Fig. 4.



Fig. 3. Battery end of Positive cable cut and prepared for inserting into the Class "T" Fuse Block

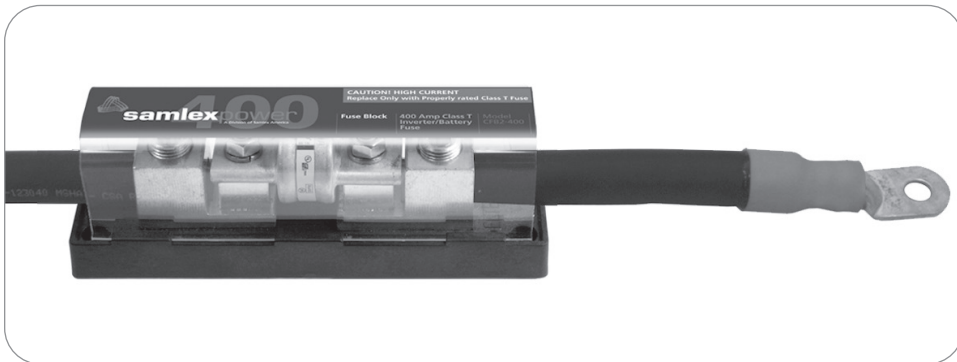

Fig. 4. Battery end of Positive cable cut and prepared for inserting into the Class "T" Fuse Block

Installation Tip: It is common that the ends of the strands towards the cut face of the cable get bent / frayed / spread outwards during cutting and thereby, the diameter of the cable near the cut face may increase slightly. To keep the strands towards the front pressed together for easier installation into the terminal, tightly warp insulation tape around 0.2" to 0.3" from the cut face. If required, straighten and compress the bent / frayed / spread out ends to reduce the diameter to the minimum. Now insert the leading 0.2" to 0.3" bare portion into the hole. Once this leading portion has entered the hole, remove the insulating tape and insert the bare end of the cable fully.



Caution!

Ensure that all the strands get inserted into the hole and that no strand(s) are left forced out of the hole.

DIMENSIONS

	mm (inches)
CFB1-200	1.69 (42.9)
CFB2-400	1.84 (46.8)

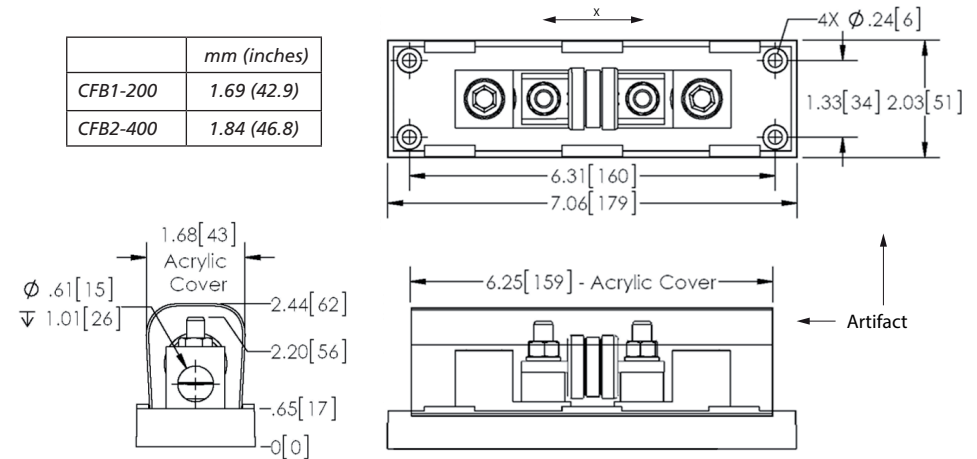

Fig. 5. Fuse Block Dimensions